Section 06: Axis Drive Systems

Axis Drive Systems



DANGER! Hazardous voltages in this enclosure can kill.
Use extreme caution when working in this area!

Amplifier Chassis Operation

All of the amplifier chassis that Fadal uses have the same basic operation.

The inputs to the chassis consist of Power input, which is either 86 VAC 3 phase or 120 VAC single phase, for DC machine and 230 VAC 3 phase, for AC machines, 120 VAC Fan (1100-1 TB2-1 & TB2-2) and a Control Signal 120 VAC (1100-1 TB1-8 & TB1-9). The Fan input is a 120 VAC to run the fans on the chassis and will be on whenever the machine is powered up. This input is fused on the 1100-1 Power Distribution Board with F23. The Control Signal is 120 VAC that activates the chassis' solid-state relays to allow the Power input to flow to the Bridge Rectifiers to convert the AC input to DC voltage for Amplifier power. This control signal comes from the 1100-1 TB1-8 and TB1-9 (this is the E-stop circuit amplifier controller enable signal from K2). From the rectifiers, the voltage is filtered by the large blue capacitor or bank of capacitors with a bleeder resistor.

On the AC Brushless amplifier chassis, the Regen Regulator or Voltage Comparator and a regen resistor provide the motor braking. The AC amplifier and chassis operate similar to the spindle drive. This circuit is connected to the DC busbus for the amplifier power and if the busbus power exceeds 400 or 420 Volts DC, the regen circuit turns on and dumps the excess power into the regen resistor.

The amplifier chassis bus voltage is measured across the blue capacitor or bank of capacitors and should about 120 VDC for 3 phase input DC amps, 160 VDC for single phase input and 320 VDC for AC amps.

Troubleshooting the Amplifier Chassis

If the amplifier chassis bus voltage is too low or zero, then check:

1. The power voltage input.
2. The control voltage input.
3. The fuses on the inputs to the chassis.
4. Disconnect the amplifiers (caution, do not allow the wires to touch any metal) and measure the bus voltage. If the voltage is good then one of the amplifiers is pulling the voltage down.
5. The solid state relays (see instructions).
6. The bridge rectifier (see instructions).
7. The capacitor(s).

If the AC Brushless chassis is not braking (stopping) the axis motors:

1. Check the regen resistor
2. Check the wire connections.
3. Replace the Regen regulator or voltage comparator.

Testing Instructions:

All the measurements performed in this instruction will be using the black lead (negative lead) in the common input. The red lead (positive lead) is the Volt, Ohm, Diode input.

Note: All readings are approximate.

Solid State Relay

With the relay disconnected from the circuit and the multimeter set to the Diode position, the contact side will read 6 to 8 Megohms and the control side will read an open, or OL on the meter, with the leads measuring one way. Swap the leads and about 1.5 Megohms will be read.

Check the circuit and verify that the control input is about 120 VAC and then check the output side, which connects to the bridge rectifier for the 3 phase power voltage. Both readings will be approximately the same.

Bridge Rectifier

The rectifiers have two AC inputs, and two DC outputs (+DC and -DC). They are marked by the terminals or they have a cutoff corner by the +DC output. With the rectifier removed from the circuit and the multimeter set to read Ohms, place the black lead on the +DC and the red lead on the AC input or the black lead on the AC input and the red lead on the -DC. The meter will read 1 to 2 Megohms. With the Red lead on the +DC and the black lead on the AC input or the black lead on the -DC and the red lead on the AC input, an open will be read.

The next three pages have the wiring diagrams for the chassis that are installed in the Fadal VMCs.

DC AMPLIFIER CHASSIS

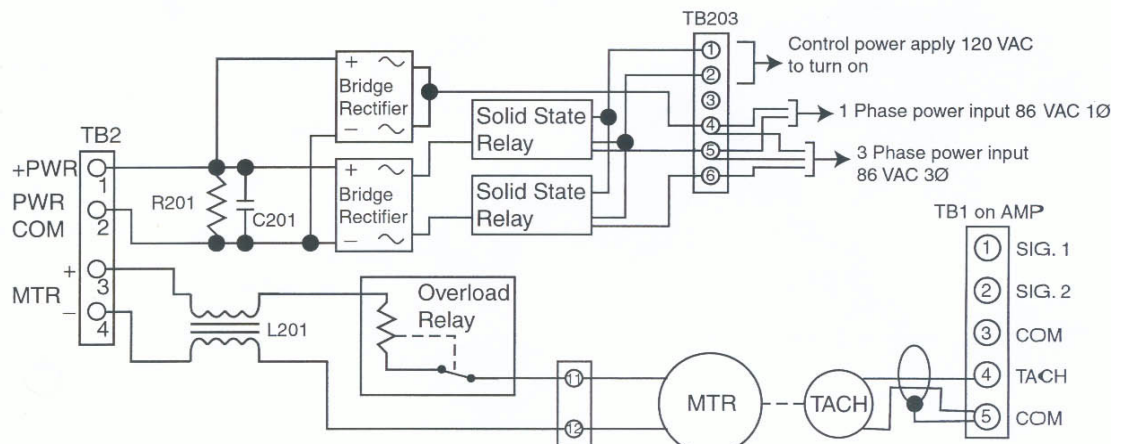
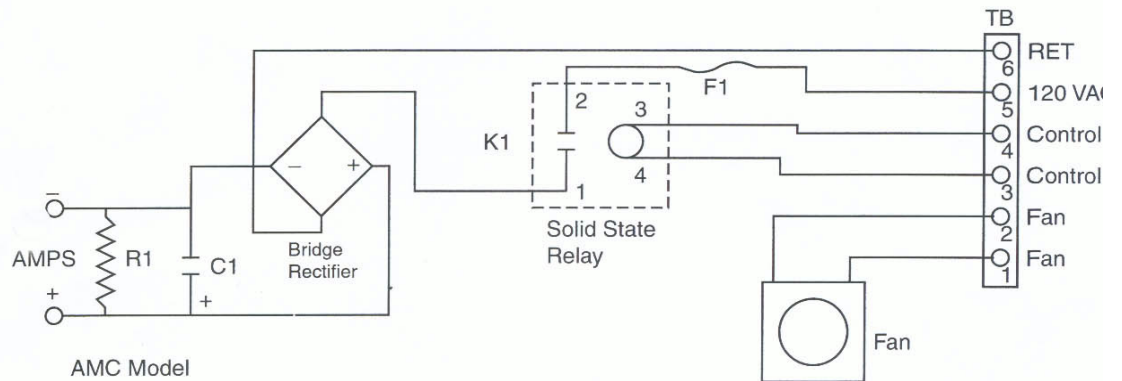
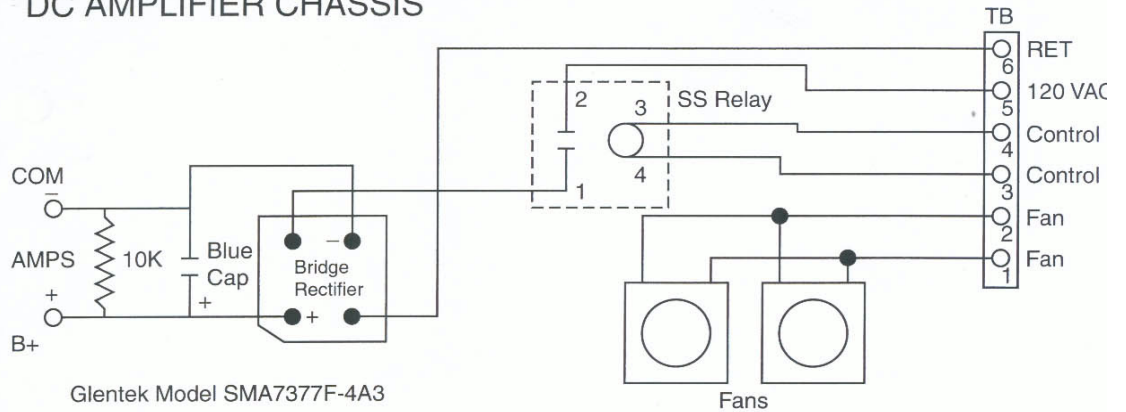

AC Brushless
Chassis Diagram

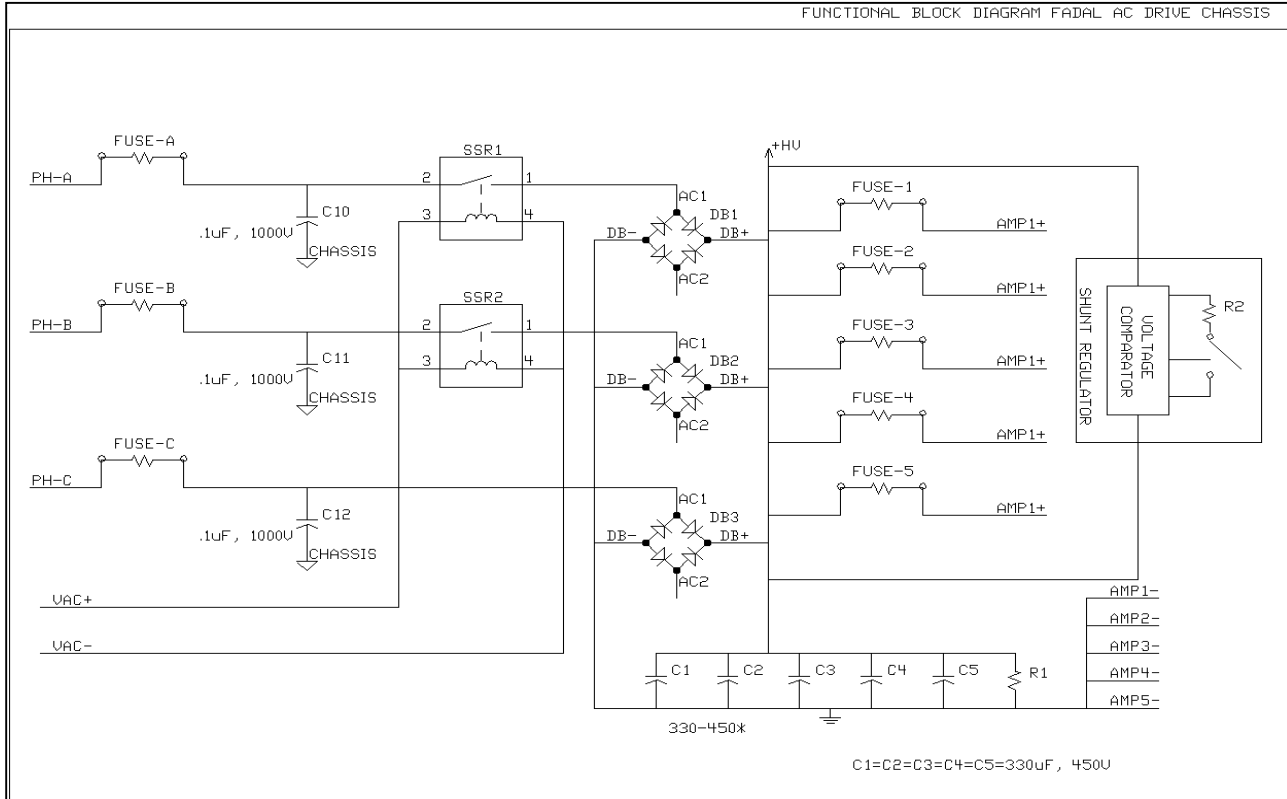

Location	Description	Manufacturer	Mfg. Part #
Fuse A,B,C	Fast acting, 30 A, 600 VAC Dimension (13/32" x 1 1/2")	Littlefuse	KLK30
Fuse 1,2,3,4,5	Fast acting, 20 A, 600 VAC Dimension (13/32"x1 1/2")	Littlefuse	KLK20
C10,11,12	.1 μ F,1000 V 20% ceramic capacitor	Cera-mite	10GAP10
C1,2,3,4,5	.330 μ F,450 V electrolytic capacitor	Illinois Capacitor	337LBA450M2EF
SSR1, SSR2	solid state relay	Gordos	G240A45
DB1,DB2,DB3	35A, 400V bridge rectifier	General Instruments	BBPC35-04
R1	20 K Ω 10W bleeder resistor	Various	20K,5%
R2	30 Ω 50W dumping resistor	Dale	RH5030

**Brushless Amplifier
Chassis AMP-0028**

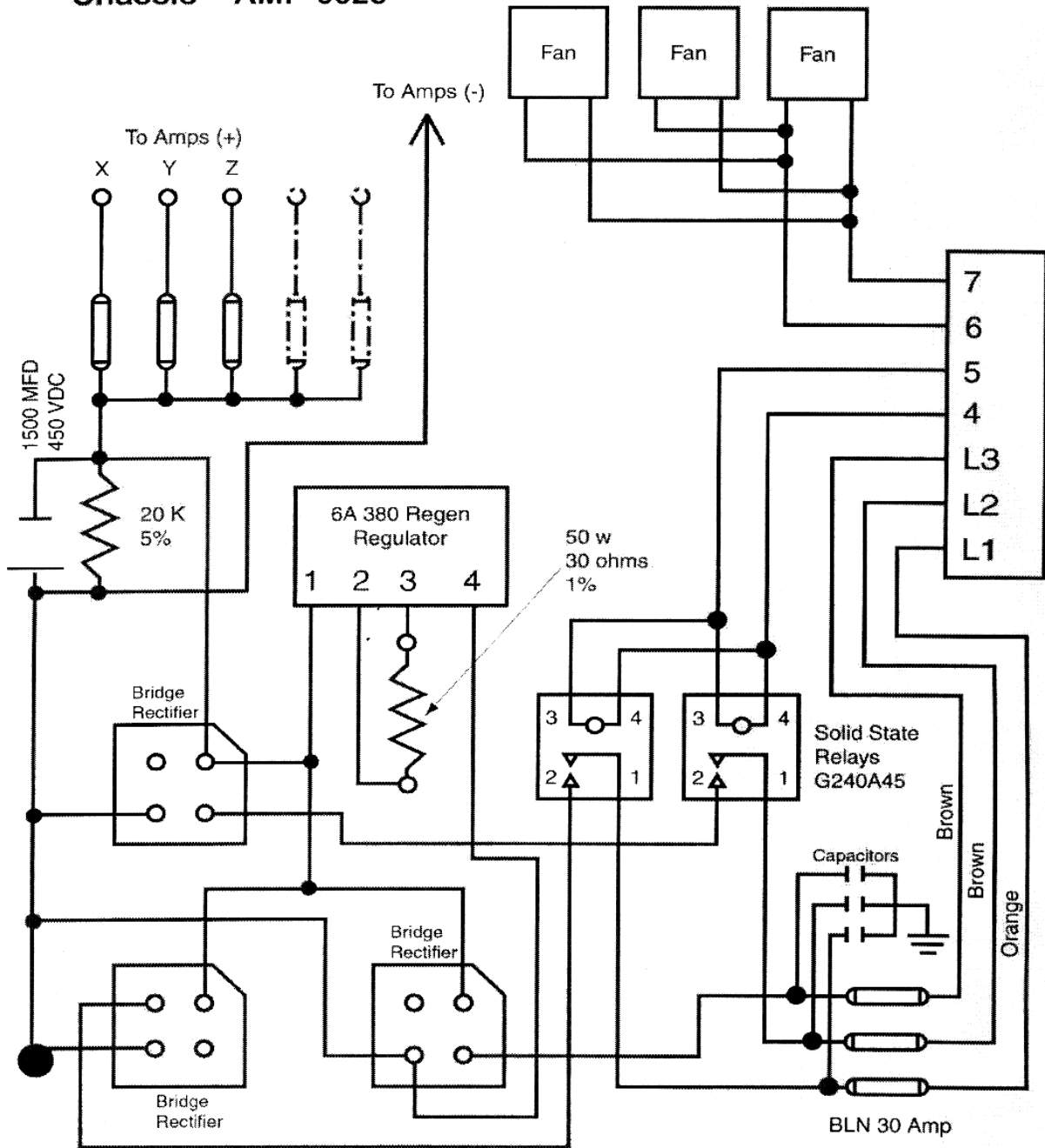

Amplifiers

Both DC and AC axis drive amplifiers are Pulse Width Modulation (PWM) type. PWM is a method to output high current efficiently.

For the DC drives this is achieved by turning the power transistor on to full voltage output and then turning them off for no voltage output. The width of the pulse will determine the output average current that drives the motor. The process is done very fast to eliminate audible noise but the speed creates more electrical noise. When the amount of time the pulse is turned on is increased the average current is increased. If the time that the pulse is turned on is decreased the average current is decreased. The width of each pulse is the same so that a DC output is obtained. The output current is filtered to remove the electrical noise. Then the signal is outputted to the motor, through choke coils on some chassis. A DC tachometer is used to monitor the motor velocity. The tach outputs a DC voltage to represent a speed in RPMs that is 7 VDC per 1000 RPM. A resolver is used to feedback the position. The resolver has two input signals generated by the Clock Board, they are called SIN and COS and are 10 VAC peak to peak (about 3.54 VAC on a meter). The resolver uses these two to generate a third signal. Resolver signal is 5 VAC peak to peak (about 1.77 VAC on a meter). Each Axis Controller board receives the resolver signal at J2 bullet connector. This voltage can be checked at this point. The voltage must very close or there may be a problem with it. The controller compares the SIN and resolver signals to determine the position.

For the AC drives, this is achieved by turning the power transistors on to full voltage output and then turning them off for no voltage output. The width of the pulse will determine the output average current that drives the motor.

By varying the pulse slightly from pulse to pulse and using both positive and negative voltage an AC signal can be obtained. The process is done on three lines, each 120 degrees out of phase with each other. The axis motors are three phase motors. The frequency of the three phase input signal determines the RPM of the motor, the current determines the torque and the phasing determines the direction of rotation. An incremental encoder provides position information from the motor. It operates with light source through a focus lens through rotating glass disk with precision etched lines through a light mask to two photoelectric cells offset 90 degrees from each other. This creates 5 volt square waves A, /A, B, /B. A and /A are 180 degrees out of phase as well as B and /B are 180 degrees out of phase. A and B are 90 degrees out of phase, by counting the pulses the position can be determined and the direction is determined by is A or B the first signal. This information is sent to the controller board. The 3 phase input from the hall effect (U,V,W) returns the rotor position feedback for the amplifier to compensate the magnetic fields to optimize the

motor operation. The motor has a temperature sensor to detect over temperature in the motor, and information is returned in the hall effect cable. The amplifier sends a Absolute Current signal to J3 on the controller board. This signal is 1 volt for every 4 amperes output by the amplifier. The amplifier provides test points, they are: Signal – is a 1:2 output of the differential signal = & - input, Tach – a scaling output of 4 volts per 1000 RPM created by the amp from the encoder information, ABS – the current output to all 3 phases. Scaling is 1 volt per 4 amperes.

Both amps have a output of 10 VDC used for the fault signal in the E-stop circuit. They all also have inputs from the controller commanding speed and direction.

DC Axis Drive Systems

Note: Set the master feedrate clock before beginning this procedure. The Position Loop Gain and Master Feedrate Clock are interrelated.

DC Amplifier Adjustment

- 1) Enter the following program:
 - a. X-4. Y-4. Z-4. G1 F150. M49,M91.
 - b. X4.Y4.Z4.
 - c. M99P1
- 2) Press Auto, to start the program running.
- 3) At the amplifier to be adjusted, use a small screwdriver and turn the SIG2 potentiometer until the monitor's display of the appropriate axis reads the following error: 595 - inch ballscrew / 302 - metric ballscrew.
- 4) Press the SLIDE HOLD button on the keypad and adjust the balance of the amplifier to read between 0 - 1.
- 5) Press the START button on the keypad and the program will start again. Verify that the following error is still 595 or 302.
- 6) Press the SLIDE HOLD key to stop the machine. Press the MANUAL key and then type SETCS and HO, to send the machine home. Adjustment of the amplifier is complete. Repeat the procedure for all axes.

**Axis Software
Version AC0017-5
for AC Drive VMCs**

To improve the floor finish using G8 command, the default Contouring Gain has been changed. The Position Loop Gain #5911 program now requires different amplifier settings than previous axis software. VMC 6535 and 8535 also are set at different values from the other machines.

The Rapid Gain for the VMC6535 and 8535 is different from other 900 IPM machines. The Following Error will be around 3200 for X and Y axes in G0.

**Procedure for
Setting Loop Gain**

This procedure has been changed from earlier versions and is applicable when AC0017-5 is installed on the Controller Cards. While amplifier adjustments may not require any changes when removing earlier software and installing AC0017, the adjustments should be verified.

The Balance program #5811 is not changed, and should be as follows:

N1	L100
N2	X-6. Y-6. Z-6. F150. G1 G91
N3	X6. Y6. Z6.
N4	M17
N5	M30
N6	M49 M91 (M91 sets the Normal Gain, and is important with AC0017-5)
N7	L101.1
N8	M2

Following the procedure for POSITION LOOP GAIN, please note the changes below. The Following Error displayed will not be the same as earlier versions of AC axis software when the AXIS DISPLAY Parameter in SETP is set to ERR.

	When M91 is active then Following Error:
AC Drive Machines with INCH Ballscrews: VMC 2016L, 3016L, 6030, 8030	600
AC Drive Machines with METRIC Ballscrews: VMC EMC, 2016L, 3016L, 4020, 4020A, 5020, 3020, 4525, 6535, 8535	600
AC Drive Machines with METRIC Ballscrews: VMC TRM	1200
AC Drive Rotary Tables-A-Axis	680
AC Drive Rotary Tables-A-Axis	680

M91 can be used to restore DEFAULT gain. This is identical to M90P50.

M92 can be used to increase gain for crisper performance. This is identical to M90P150.

M90Pxxx can be used to MODIFY gain where xxx represents the GAIN MODIFICATION FACTOR. The value used may range from 50 to 200, and is modal until POWER OFF, or until changed with another M90Pxxx, M91, or M92 command. This allows the user to freely select any appropriate gain value, and restore to the DEFAULT gain with M91, assuring flexibility over the performance of the machine.

**Setting Cold Start
Position**

Cold start the VMC. The axis motors are now at their index marks. The VMC cold start indicators may be misaligned. The following procedure will measure the offset value.

X-Axis

- 1) Use a tape measure to measure the length of the table. Mark the center point with a marker or pen. Measure the table again, except, this time start measuring from the other end of the table. Mark that point.
- 2) Remove the cover from the X axis motor. Loosen the three screws that are securing the resolver.
- 3) Put a small drill into the spindle and jog the head down until the drill is approximately .100"[2.54mm] above the table. Move the X axis in either direction, by turning the resolver, until the drill is centered between the two marks that were made in step #1.
- 4) Tighten the three screws on the resolver and replace the motor cover.

Y-Axis

- 1) Press the MANUAL button until ENTER NEXT COMMAND is displayed. Type Ho, press the ENTER button, and then press the START button. This will send the machine back to the original cold start position.
- 2) Put a .0005"[.001mm] indicator into a tool holder and insert the tool holder into the spindle. Jog the Z axis and the Y axis until the indicator is centered inside the center T-SLOT, while rotating the tool holder.
- 3) Remove the cover from the Y axis motor and loosen the three screws that are securing the resolver.
- 4) Turn the resolver on the Y axis as needed, to position the indicator so that it reads the same value on both sides of the T-SLOT, while rotating the tool holder.
- 5) Tighten the three screws on the resolver and replace the motor cover.

Z-Axis

Refer to the Automatic Tool Changers Section for procedures on setting the Z axis cold start.

**Replacing A Servo
Amplifier**

- 1) Power off the VMC.
- 2) Lock out/tag out the machine.

- 3) Remove the orange connector or disconnect signal wires on the front of the faulty card.
- 4) Disconnect the power and motor wires.
- 5) Using a long phillips screw driver, loosen the two screws securing the amplifier to the chassis. Slide the amp to the other side and remove.
- 6) Replace the amplifier.
- 7) Reconnect the orange connector or signal wires on the front of the new card making sure that they are installed on the correct terminals.
- 8) Connect the Power and Motor wires, insuring their correct position.
- 9) Turn the Loop Gain and Current Limit potentiometers fully clockwise.

A axis amplifier slot #1 (far left when installed)
X axis amplifier slot #2
Y axis amplifier slot #3
Z axis amplifier slot #4

After replacing one or more of the servo amplifiers or if an axis motor has been replaced, you must adjust the position loop gain.

Setting Gain For The 1010-5

Using software to set the gain enables the user to change gain setting on the fly in their part program.

We recommend that the gain be set to normal at all times in the SV and if high gain is desired use the M codes described below in the part program.

M90 = Default to gain set in the SV
M90 P# = Programmable gain
M91 = Normal gain
M92 = Intermediate gain
M93 = Maximum gain

Verify The Gain Setting In The SV

- 1) Return the machine to its COLD START position.
- 2) At the prompt "ENTER NEXT COMMAND", type SV, which will start the survey program.
- 3) Next select the X axis, and when the menu appears select #2 from the menu. This will read the current settings on the axis controller.
- 4) After reading the axis controller settings, the CNC will display the current gain setting. Menu selection #6 should read "CURRENTLY = NORMAL."

- 5) If the gain setting is not set to NORMAL select #6 from the menu and then press 0 to select normal gain. After selecting the gain, press selection #3 to write the setting back to the axis controller.



IMPORTANT

Changes to the setting must be written back to the axis controller or they will not be permanent.

- 6) Once the X axis has been verified do the same for all the other axes.
- 7) Verify that all axes have the same gain settings.

Troubleshooting DC Amplifiers

If errors occur or an axis is inoperative, go to the Troubleshooting Section. Flow chart number 4 is for axis control problems.

AC Drive Systems

Information and Connections

Motor

Cont. Torque @ 20 deg C	75 in.-lbs. (.864 newtons)
Peak Torque	240 in.-lbs. (2.77 newtons)
Resistance	1.9 ohms
Inductance	10.0 mH
Back EMF	78 V/k RPM
Weight	39 lbs. (17.69 kg)
Motor leads.	ØR red, ØS blue, ØT black
Encoder	Heidenhain ROD426 encoder
.	8192 lines (32,768 counts)
.	14 pin connector
Hall Signals and Temp Switch	10 pin connector

Amplifier Chassis

Wago connector on bottom	(L1,L2,L3, 4,5 (120VAC for SSR), 6,7 (120VAC fans)
Amplifier sequence	X, Y, Z, A, B (from top)
Fuse sequence on power supply	X, Y, Z, A, B (from front to back)

Amplifier

Supply voltage230 VAC 3phase
 Bus voltage325 VDC
 Current30A peak (3 sec.) 19A continuous
LSECB trips for anything above 9A for
 longer than 3 sec.
 Bus Capacitor1500 uF 450 V
 Regen (if equipped):
On 400 VDC
Off 350 VDC
Fault 450 VDC

Load Percentage to Amperage Conversion

100% = 19. Amps
 50% = 9.5 Amps
 10% = 1.9 Amps
 5% = .95 Amps
 1% = .19 Amps

Physical Layout

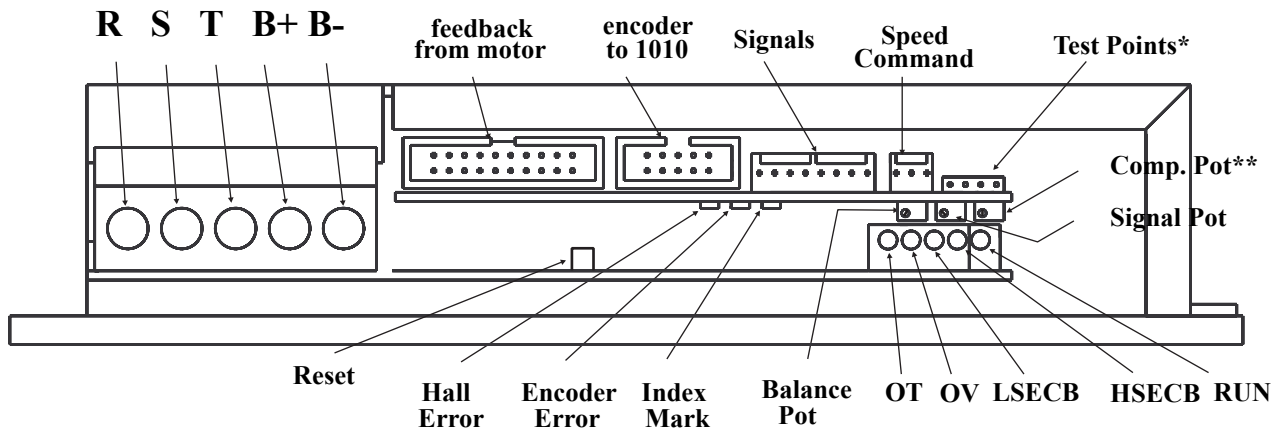

Figure 6-1 Glentek Amplifier

*For the TRM, test points are replaced with RJ45 connector for communication.

** There is no Comp Pot on the TRM amp.

3 or 4 pots: Not all amplifiers have Loop Gain Pot

Loop Gain	single turn pot	CW to increase gain
Balance	12 turn pot	
Signal Gain	12 turn pot	CW to increase gain
Compensation	12 turn pot	CCW to increase

Three Surface Mount LEDs:

Hall Error Red (invalid Hall state or illegal encoder transition)

Encoder Error Red (Heidenhain encoder error signal)
 Index Mark Green

Five Standard LEDs:

Over Temp Red (motor or amplifier)
 Over Voltage Red
 L.S.E.C.B. Red (low speed overcurrent)
 H.S.E.C.B. Red (high speed overcurrent)
 Run (or ON) Green

Signals Connector (from left) See pinout descriptions for 8-pin Molex Connectors

COM
 COM
 Absolute Current Output
 Fault I/O
 Total Inhibit
 - Limit Switch
 + Limit Switch
 +12V output

Test Points (from left)

COM
 Absolute Current 1V/4A
 Tach 4V/1000 RPM
 Signal

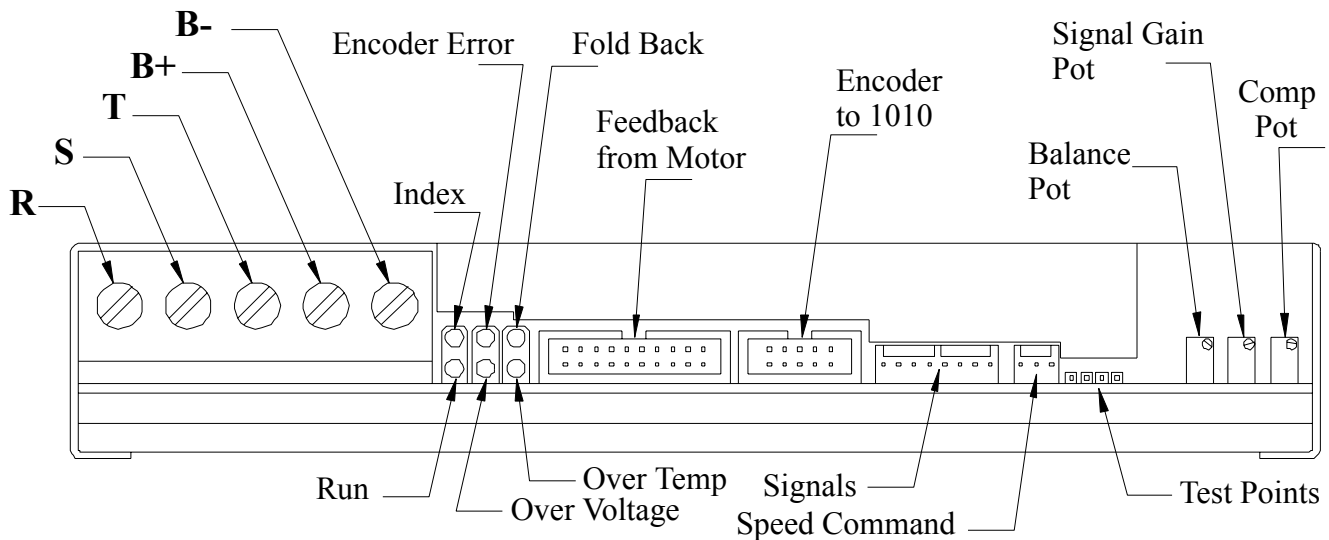

Figure 6-2 AMC Amplifier

3 Pots:

Balance 10 turn pot

Signal Gain 10 turn potCW to increase sig gain
 Compensation 10 turn potCCW to increase amp gain

6 LEDs:

Top Row:

Foldback Red(OC folds back to continuous after 2 secs.)
 Enc. Error Red(solid red for encoder error;
 blinking if amp returns to trap mode)
 Index Mark Green

Bottom Row:

Over Temp Red(motor or amplifier)
 Over Voltage Red(high speed overcurrent or bus over-
 voltage)
 Run (or ON) Green

Signals Connector (from left) See pinout descriptions for 8-pin Molex Connectors

COM
 COM
 Absolute Current Output
 Fault I/O
 Total Inhibit
 - Limit Switch
 + Limit Switch
 +12V output

Test Points (from left)

COM
 Absolute Current 1V/4A
 Tach 4V/1000 RPM
 Signal

Amplifier Power Connectors

S.....white wire
 T.....black wire
 B+.....red wire
 B-.....black wire

20-pin IDC on amp to

1.....A+.....green
 2.....A-.....red
 3.....+5V.....light blue
 4.....+5V.....light blue
 5.....M+.....white
 6.....M-.....orange

7	COM	black
8	COM	black
9	B+	brown
10	B-	yellow
11	ENC.ERR.	purple
12	nc		
13	nc		
14	U	gray
15	V	tan
16	W	brown
17	TEMP	dark blue
18	+5V	pink
19	COM	black
20	SHIELD		

10-pin IDC on amp to

1	A+	green
2	A-	red
3	+5V	blue
4	+5V	blue
5	M+	white
6	M-	orange
7	COM	black
8	COM	black
9	B+	brown
10	B-	yellow

8-pin Molex on amp

1	+12V	for Limit switches (unused at this time)
2	+Limit	to +Limit switch for axis (unused)
3	-Limit	to -Limit switch for axis (unused)
4	Inhibit	unused at this time
5	Fault	to axis fault line (1100-1 TB1 2-5) active low
6	Abs Current	Absolute current (1V/4A) to J3 on 1010
7	Common	for axis fault line
8	Common	for Limit switches (unused)

3-pin Molex on amp to

1	Command Signal +	red	1010	J11-1 X&Y	J11-2 Z
2	Command Signal -	black	1010	J11-2 X&Y	J11-1 Z
3	Shield	shield	1010	J11-3	

Test Points:

- SIGNAL is a 1:2 output of the differential Signal+&- input.
- TACH scaling is 4V/1000 RPM.
- ABS is the current output to all 3 phases. Scaling is 1V/4A. It is the peak value (but not showing all the spikes). It is an absolute value; it does not show direction.
- COM is common (logic ground for the above signals).

Features Axis Controller Card 1010-5B/C

Encoder feedback (J5)
Able to work with scales
J1 and J2 no longer used
J3 current sensor (input)
J11 differential output
Brushless software labeled AC-_____
Position Loop Gain adjusted by LED, 25ipm

AC Axis Adjustments

Before adjusting any amplifiers, verify that scale cables (if applicable) are disconnected. If they are not disconnected, power down the machine, disconnect the cables, and then power up the machine.

Potentiometer Adjustments (Axis Amplifier)

- 1) Turn the Loop Gain, or Current, Potentiometer all the way clockwise (a clicking sound will be heard when the pot has reached the limit).
- 2) Slowly turn the Compensation Potentiometer counter clockwise until the axis motor produces a high frequency vibration, then turn the potentiometer clockwise 1-1/2 turns.
- 3) To adjust the Gain and Balance, the following program will be used:

```
N1 M91 M49 G91 F150.  
N2 X-3.Y-3.Z-3.  
N3 X3.Y3.Z3.  
N4 MPP P2
```

The Signal gain and Balance can be set for either metric or inch pitch ballscrews.

Metric

- 1) Use a Multimeter set for VDC. Attach the black lead to the signal - (COM) and the red lead to the signal +.
- 2) Start the program and adjust the Signal Gain potentiometer until the multimeter reads 1.470VDC.

- 3) Adjust the balance potentiometer until the multimeter reads 1.470VDC in both directions.
- 4) When the above steps have been completed, the monitor will read 302 for the following error.
- 5) Repeat steps 1-4 for the remaining axis amplifiers.

Inch

- 1) Use a Multimeter set for VDC. Attach the black lead to the signal - (COM) and the red lead to the signal +.
- 2) Start the program and adjust the Signal Gain potentiometer until the multimeter reads 2.880VDC.
- 3) Adjust the balance potentiometer until the multimeter reads 2.880VDC in both directions.
- 4) When the above steps have been completed, the monitor will read 595 for the following error.
- 5) Repeat steps 1-4 for the remaining axis amplifiers.

Note: The following amplifier adjustments are made with the VMC set to INCH. Use the parameters page (SETP) to verify or change modes.

Axis Card Adjustments

Adjusting the amplifiers with the axis cards is done by using the red Light Emitting Diodes (LEDs) while adjusting the potentiometers. In order to use this method, the axis cards must have software version AC0003-5 or higher.

Balance

- 1) Press the MANUAL button until the ENTER NEXT COMMAND screen is displayed.
- 2) Type DI and press the ENTER button. Type DL, and press the ENTER button. This will display the percentage of load, instead of the axis following error, in 1% increments. This command prepares the axis card for balancing the amplifiers.
- 3) Press the MANUAL button to return to the ENTER NEXT COMMAND mode. Observe the red LED on the axis card. If the light is on or is blinking, the amplifier is not properly balanced.
- 4) Turn the Balance potentiometer, on the amplifier, until the LED goes out. The slower the light blinks, the closer the amp is to the balance point. If the LED starts blinking faster, the potentiometer is being turned the wrong way.

Signal Gain

- 1) After the balance has been adjusted, the Signal Gain must be adjusted. Change the program that was entered on the previous page to read as follows:

```
N2 M91 M49 G91 F25.  
N3 X-2.Y-2.Z-2. G1  
N4 X2.Y2.Z2.
```

- 2) Start the program. With the program running, observe the red LED on the axis card. The red LED should not be on. When the axis changes direction the LED will come on for a brief interval and go out until the next change of direction. Adjust the Signal Gain on the axis amplifier, until the light goes out. If the light goes out in one direction, but not the other, the balance will have to be adjusted again.
- 3) Perform the Balance and Signal Gain adjustments on the remaining axes. If the desired feed rate for adjustment purposes is 25 ipm (F25), mm pitch ballscrews will have a following error of 50 and Inch pitch ballscrews will have a following error of 100. Rotary tables will always have a 2000ipm feed rate for 90:1 ratios and 1000ipm for 180:1 ratio and a 680 following error. If the VMC is being adjusted for rotary dies, using a feed rate of 150 ipm, the following error for the X,Y, and Z axes is 465. The following error for 25 ipm is 78. The A and B axis still use a 2000 ipm feed rate. The following error is 540.

Troubleshooting AC Amplifiers

If errors occur or an axis is inoperative, refer to the Troubleshooting Section. Flow chart number 4 is for axis control problems.

SV Command

The survey command (SV) is a utility that manages the axis compensation data. Each axis controller card stores the screw compensation, the zero offset, and the servo gain settings. To view or edit data, you must use the SV command.

Using SV

The previously used SV utility program was replaced in System 98 with a more advanced and easier to use editing utility screen. When entering the survey menu (type SV at the ENTER NEXT COMMAND prompt), the survey menu now automatically loads the survey into memory, starting with the default X Axis survey. If no survey exists, a new empty survey will be created. The survey is then automatically displayed on the screen in groups of 40 values at a time. If more than 40 values in any given survey exists, there will be an additional option located at the bottom of the first column called SURVEY VALUES. This option will allow the user to toggle between Page 1 (the first 40 values) and Page 2 (the remaining values), of the survey. The zero offset and gain options are also displayed on the bottom of the first column.

**Review or Change
Survey**

To edit any values, the user must move a cursor, defined by an asterisk (*) symbol, around the screen. This cursor may be moved up, down, left, or right by pressing the U, ENTER, D, BACKSPACE or the L and R keys respectively. To change the axis that is currently being displayed, the user must move the selector cursor to the currently selected axis located at the top of the first column. At this point, the user will be prompted with an ENTER AXIS ID prompt. The user may now type in the desired axis (X, Y, Z, A, or B).

The actual survey values may be altered by moving the selector cursor to the desired index location and then typing in the corresponding value. The editor will then place the value in the correct location and will check for errors. Errors will occur if the difference in the values of two adjacent indexes is greater than 9. If errors are found, the brackets around the index value will change from square brackets, [], to round brackets, (). All of the numerical errors must be corrected before the user is enabled to exit the menu. The menu may be exited by pressing the MANUAL key, or by selecting another axis in the survey menu.

Two new editing features have been added to help speed up the process of entering similar index values. The first feature, called the ALL command, is invoked by pressing the A button while the selector cursor is located on any index value. This command will give all of the indexes following the currently selected index the same value as that index. If, for example, the last 10 survey values all had the value of 1, the user may type the first 1, move the selector cursor back up to that value, and press the A button. The last 9 indexes will now have the same value as the selected index.

The second feature is used if a currently selected index has the same value as the previous index, then the user may press the space bar to copy the previous survey value into the current index. This feature may be used when adjacent index values have the same value.

**Determining the Zero
Offset**

Cold start the VMC. With the Zero Offset set to 0, the axis motors are now at their index marks. The VMC cold start indicators may be misaligned. The following procedure will measure the offset value.

X-Axis

- 1) Use a tape measure to measure the length of the table, with the end covers removed. Mark the center point with a marker or pen. Measure the table again, except, this time start measuring from the other end of the table. Mark that point.
- 2) Put a small drill into the spindle and jog the head down until the drill is approximately .100" (2.54 mm.) above the table. Move the X axis in either

direction, by turning the resolver, until the drill is centered between the two marks that were made in step #1.

- 3) The number on the monitor, in the X axis display, is the offset amount. Record the value on a sheet of paper.

Y-Axis

- 1) Press the MANUAL button until ENTER NEXT COMMAND is displayed. Type HO, press the ENTER button, and then press the START button. This will send the machine back to the cold start position.
- 2) Put a .0005" indicator into a tool holder and insert the tool holder into the spindle. Jog the Z axis and the Y axis until the indicator is located in the center of the T-SLOT of the table.
- 3) Jog the Y axis as needed to position the indicator so that it reads the same value on both sides of the T-SLOT, while rotating the tool holder.
- 4) Record the value on a sheet of paper.

Z-Axis

Refer to Section One of this maintenance manual for procedures on Z axis cold start.

Changing the Zero Offset

The zero offset is used for scales and AC drives. The zero offset will move the axis in 0.0001 of an inch (0.00254mm) increments from the cold start position. To reset the zero offset, follow these steps:

- 1) In the SV program, move the selector cursor to the Zero Offset Index position, and enter the value of 0 (zero).
- 2) Press Manual to save the survey and exit.
- 3) Determine the proper offset value:

AC-Drive Systems:

Cold Start all 3 axes, and then Jog from the Cold Start position to the measured position (section 2.2.3). After moving to the measured point, insert the value, displayed on the monitor, into the SV program at the Zero Offset Index selection. When entering offsets, use the following examples as a guideline:

If the position recorded was .0105, enter 105.

If the position recorded was -.1350, enter -1350.

Scale Systems:

Use the SVT-0081 Encoder Tester (1000 line). Disconnect the scale feedback cable from the Axis Controller card and connect it to the Encoder Tester.

Connect the Encoder Tester to the spindle controller card for 5-volt power. Cold Start the axes, and Jog the axis until the closest green index light is seen. Insert the position value, displayed on the screen, into the SV program at the Zero Offset Index selection, and change the sign from + to - or from - to +.

Changing Gain

The default gain option may be changed by moving the selecting cursor to the change gain index. Select either normal, intermediate, or maximum gain.

Saving a Survey to the Axis Control Card

A survey may be saved by either exiting out of the survey menu by pressing the Manual key, or by selecting another survey to edit. On exiting, the CNC will automatically cold start to enable the changes. If a survey has not been altered before exiting, the CNC will not require a cold start. This new feature allows the user to go into the survey menu just to look at the current settings, without having to wait for a cold start when exiting.

If a mistake has been made and a user wants to reload an axis without saving the changes, move the selector cursor to display the Enter Axis ID prompt. At this prompt, re-enter the axis that is currently being edited. The message "Do You Want To Save Survey Before Re-Loading (Y/N)" will appear. Press "N" to reload the survey without saving the changes.

Copying a Survey To A New Axis Control Card

If an axis card needs to be replaced, copying the survey to a new axis card can be accomplished by using two new features called the SVREAD and SVWRITE commands. To replace an axis card, follow these steps:

- 1) Type SVREAD at the Enter Next Command prompt. All of the surveys will automatically be loaded into memory.
- 2) Shut off the machine and exchange the axis card to be replaced.
- 3) Turn the machine back on and type SVWRITE at the ENTER NEXT COMMAND prompt.
- 4) When prompted, type in which axis is to be replaced.
- 5) The survey will be automatically saved and a "survey successfully saved" message will be displayed.

Another method of copying axis surveys is to save them to disk using the PU,5 command. This option may also be used to prevent any accidental losses of surveys. To load a saved survey from a disk, the user must enter the diagnostics option (option 7) in the Functions menu. A submenu will appear with the option, 5-LOAD CONFIGURATION. If this option is invoked, the user will be asked for the filename of the survey. The survey will now be automatically loaded and saved. Note that any previously stored survey will be destroyed. To

prevent a user from accidentally loading in a survey, the survey may not be loaded in through the disk command in the functions menu.

Axis Motors (XYZ)

Motor Wiring

When installing an axis motor, it is important to wire the motor the same way that the one before it was wired. If the motor is from a different manufacturer, use the table below correctly wire that particular model or brand. Each motor has four wires, two wires for the power and two wires for the tachometer feedback. Connecting these wires the wrong way will result in axis motor runaways.

AXIS MOTOR WIRING DATA FOR THE X, Y, AND Z AXIS

MOTOR TYPE	VMC	MOTOR WIRE			TACH WIRE			TESTING WIRE CONNECTIONS					
		AXIS	CNC	MOTOR	AXIS	CNC	MOTOR	DIRECTION OF TABLE AND HEAD		DIRECTION OF MOTOR SHAFT WHEN MOTOR IS DETACHED FROM BALL SCREW			
RELIANCE E728	5	X	RED BLK	BLK RED	X	RED BLK	WHT BLU	X	+	-	X	+	-
	10	Y	RED BLK	BLK RED	Y	RED BLK	WHT BLU	Y	-	+	Y	+	-
	15	Z	RED BLK	BLK RED	Z	RED BLK	BLU WHT	Z	+	-	Z	+	-
GLENTEK GM4050	5, 10	X	BLK RED	BLK RED	X	RED BLK	BLK WHT	X	+	-	X	+	-
	15	Y	BLK RED	BLK RED	Y	RED BLK	BLK WHT	Y	-	+	Y	+	-
	2216 3016 4020	Z	BLK RED	BLK RED	Z	RED BLK	WHT BLK	Z	+	-	Z	+	-
GLENTEK GM5065	6030	X	RED BLK	BLK RED	X	RED BLK	WHT BLK	X	+	-	X	+	-
	8030	Y	RED BLK	BLK RED	Y	RED BLK	WHT BLK	Y	-	+	Y	+	-
		Z	RED BLK	BLK RED	Z	RED BLK	BLK WHT	Z	+	-	Z	+	-
GLENTEK GM6000	*VASAK (RED)	X	RED BLK	WHT BLK	X	BLK RED	WHT* BLK	X	+	-	X	+	-
	6030	Y	RED BLK	WHT BLK	Y	BLK RED	WHT* BLK	Y	-	+	Y	+	-
	8030	Z	RED BLK	WHT BLK	Z	BLK RED	BLK WHT*	Z	+	-	Z	+	-

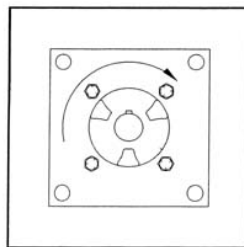

FIG. 1

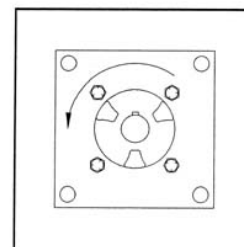

FIG. 2

FADAL 4/95

Removal

- 1) With the machine at the cold start position, depress the Emergency Stop button and power off the VMC.
- 2) Remove the four 3/8 hex head bolts holding the axis motor in place.
- 3) Remove the axis motor.
- 4) For DC motors, remove the end cap of the motor. For AC motors, remove the Rose Box cover or disconnect the cannon plugs. If the motor has cannon plugs, go to section 5.3 for installation instructions.
- 5) For DC motors, disconnect the two power wires and the two tachometer wires. For AC motors, disconnect the three wires of the power cable and the signal cable.
- 6) Loosen the 45 degree connector and pull all of the wires out of the motor.

Installation

- 1) Verify that the Emergency Stop button is pressed in.
- 2) For DC motors, remove the end cap of the motor. For AC motors, Remove the Rose Box cover.
- 3) Run the machine wires into the new motor. Tighten the 45 degree connector. For the motors with the cannon plugs, connect the power and signal cables to the new motor and proceed to step number 5.
- 4) For DC motors, connect the two power wires and the two tachometer wires using the DC chart in table 1. For AC motors, connect the three power wires together (red-red, blue-blue, and black-black or black-white, then connect the signal cable.
- 5) Reinstall the axis motor using the four 3/8" hex head screws. Center the motor during installation.
- 6) Power on the machine. Release the Emergency Stop button and observe the motor. If there is any malfunction or axis runaway, depress the Emergency Stop button.
- 7) Type CS, to cold start the machine.
- 8) Adjust the axis amplifier (section 1.1 for DC motors and 2.5 for AC motors)
- 9) Reset the cold start position (DC motors only, see section 1.2).

Resolvers

Before proceeding with the following instruction, verify that the VMC is at the cold start position and the Emergency Stop button is depressed.

Removal

- 1) With the machine at the cold start position, press the Emergency Stop button and power off the VMC.
- 2) Remove the four 3/8 hex head bolts holding the axis motor in place.
- 3) Remove the axis motor.
- 4) Remove the end cap of the motor.
- 5) Loosen the three screws that are holding the resolver in place.
- 6) Remove the two screws that are holding the resolver circuit board to the motor.
- 7) Rotate the motor shaft so that a 3/32" hex wrench can be inserted into the top screw on the resolver coupler
- 8) Loosen the screw and remove the resolver.

Installation

- 1) Insert the resolver into the coupler and hold the resolver flush to the mounting surface as the coupler screw is tightened.
- 2) Tighten the three screws that hold the resolver in place.
- 3) Install and tighten the two screws that hold the resolver circuit board to the motor.
- 4) Release the Emergency Stop button and cold start the machine. If the applicable axis is not aligned with the cold start mark after the machine has been cold started, then refer to section 1.2.

**EMC and TRM Way
Lubrication**

The EMC and TRM model VMC's must be manually lubed by the owner every 3-6 months depending on use:

- a. Remove X, Y, and Z way covers.
- b. Wipe off old grease and accumulated foreign objects.
- c. Use MOBILTEMP SHC 32 grease.
- d. Grease every lubrication port at the saddle, table, and head. Supply grease until it comes out from the ball slide or ball nut area.
- e. Move saddle, table, and head a few times through full travel to spread the grease throughout the system.
- f. Wipe off excess grease that accumulates at the end of the rails and ball screw shafts.
- g. Re-install X, Y, and Z way covers.

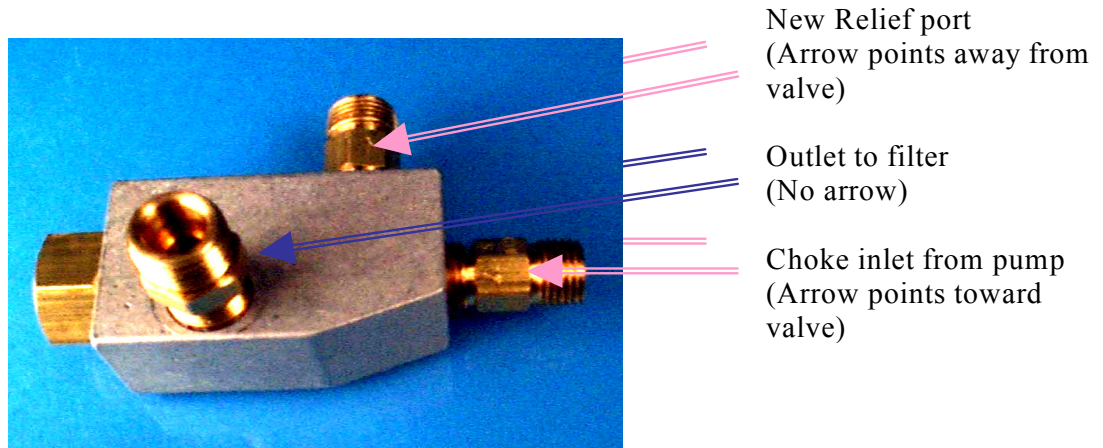
Axis & Way Systems
Waylube System

USE RECOMENDED WAYLUBE TYPE Castrol Magna BD68, Shell Tonna 68V or Mobil Vactra Oil #

Operation **Note:** Frequently clogging components indicate that the wrong waylube is being used. The recommended waylubes are Castrol Magna BD68, Shell Tonna 68V or Mobil Vactra Oil #2.

Two waylube systems have been used, the motor-driven piston pump and the Positive Displacement Injection (PDI). The early linear way VMC 15 models used hand pumped grease. For these machines use Mobil SHC32 grease and Bi-weekly grease with 3 to 4 strokes to the ballscrews and 2 strokes to the ways. **Caution:** Pump slowly to avoid damaging the lines.

The **System Software** determines the waylube cycles so both systems will operate correctly. The operation is as follows:

- One cycle is defined as: ON for 3 minutes 50 seconds and OFF for 10 seconds for a total cycle time of 4 minutes.
- After power on: two 4 minute cycles
- In Auto and not waiting mode: continuously run 4 minute cycles
- Just after exiting Auto: one 4 minute cycle.
- Enter Jog mode: one 4 minute cycle.

The CPU board issues the command to activate waylube. This command goes to the Computer Interface (1030) and then to the Mill Interface board (1040). The Mill Interface activates relay K19 on the 1100-2 board which outputs 110 VAC (TB1-11 & RET TB1-12) to the waylube pump.

The **Motor-Driven Piston Pump** type operates with the 110 VAC input running a 3 RPM motor. The motor drives some gears which move an arm up and down to pump the pump. This pump can be pumped manually by pulling up on the handle and released. The pump then pumps oil through a filter and then on to the line. The line goes to two junction blocks that output the oil through meters that restrict the amount of oil to each line to the ways and ballscrews.

The **Positive Displacement Injection (PDI)** lube system is a solenoid controlled pneumatic system. When the solenoid is activated by the 110 VAC input, it turns the air supply off and when the solenoid is deactivated the air supply is on to activate the pump. This is done so that both systems can use the same control program.

The pump is activated for 10 seconds, within the 4 minute cycle, during which oil is distributed to all of the valves on the junction block assemblies. The pump sends oil to the filter and then to the junction block assemblies, which may contain several different size valves, at a pressure ratio of 5:1. The valves inject a measured amount of oil to their respected lines. When the solenoid is deactivated the pressure is released through a relief valve. When the pressure drops below 50 psi, a spring inside the valve returns the valve to its at rest position. This position allows the injector cavity to refill with oil.

PDI Waylube Troubleshooting Observations and Tests

Observe the operation of the PDI Waylube pump throughout a 4-minute cycle **with axes moving**. Proper operation would include 120VAC power ON to the VLV-0028 Air Valve on top of the Lubrication Pump for 3 minutes and 50 seconds. This is then followed by a 10 second power OFF to the Air Valve, during which time the gauge pressure increases to 200-350 PSI (14-24 bar). Again, the 3 minute 50 second power ON cycle repeats, and the gauge pressure reduces to 0.

Air Valve Operation

If the air valve does not operate, inspect F13 fuse and K19 relay on the 1100-2 board. Use SVT-0104 Test Relay as substitution for K19. If Test Relay shows no 5VDC, then trace 5VDC circuit back to motherboard through 1100-2 / J1-7, 1100-1 / J2-7, 1100-1 / J1-23, and 1060-0 / J7-23 to the 1040-2 card. Remember that 5VDC relative to ground is present on BOTH legs of the K19 relay until it is energized by the 1040 card pulling one leg to ground. Test for 120VAC at valve coil when energized. If power is OK, then test mechanically by pressing white button on end of air valve when not energized. Air line output from valve can be disconnected to check for air flow.

Pump Operation

Disconnect output oil lines from gauge, and using a short piece of 5/32 air line, close output Y fitting by inserting the tubing, one end into each side of the Y. Cycle pump until pressure builds.

Does pressure now rise and fall from 200-350 PSI and return to 0 as described above over a 4-minute cycle? If so, then pump operates OK.

If not, is pressure at maximum constantly? Then replace LUB-0051 Choke Valve inside reservoir of pump, as it may not be releasing pressure from output when Air Valve stops air flow.

Is pressure at or near zero constantly? Then the pump piston may not be returning to top of the stroke. Disconnect the air supply, and then remove the threaded stop rod with the plastic cap on it from the top of the pump assembly. Insert a screwdriver to measure how far down the piston is. It should be at the top of the stroke).

If stuck in lowest position, then replace LUB-0038 assembly.

If piston was not stuck or does not stick at lowest position, then LUB-0051 Choke Valve may have a ruptured diaphragm. Replace LUB-0051.

The newer version of the LUB-0051 Choke Valve releases pressure when the machine is powered off. This device restricts the strong impulse from the high pressure of the pump to protect the individual injectors, but also is the relief valve when the pump is turned off, so that the pressure drops to zero to reset the injectors.

The problem is that the pressure rises to the maximum when the machine is powered off, and the constant pressure damages the valve diaphragm when the machine is not being used. If the valve is damaged, the result then is that the pressure never climbs to the maximum because the diaphragm leaks, and no lube flows, or, the pressure never declines below the 50 PSI minimum because the relief valve is blocked, and the injectors cannot reset.

The newer version has an extra port on it, as shown below, and allows the pressure to bleed off when the machine is powered off. Installation of the new Choke Valve is simple. Note that two of the ports are similar, except that a marked arrow points into the valve on one, or away from the valve on the other. Thread the port that has the arrow pointing INTO the new Choke Valve onto the pump's piston housing. Install the port tube that feeds the lube into the filter unit onto the 1/4 inch compression fitting, (it is different from the other two). The

third port has the arrow pointing AWAY from the Choke Valve and is not connected to anything at all.

If Waylube Pump is operating OK, and system cannot develop greater than 200 PSI (14 bar), then inspect system for a leak. Inspect under table for ruptured hose and replace with LUB-0071 or LUB-0073 Waylube Carrier Update kit.

If OK, then one of the PDI Injectors may be leaking. Determine which manifold is leaking by isolating each section separately. Inspect Injectors for one that is not seating. Replace LUB-0083, LUB-0084, or LUB-0085 Injector or complete Manifold assembly.

Checking Ways for Oil (Both)

- 1) Look under the head on the Z-axis ways for a thin film of oil flowing down the column ways.
- 2) Look behind the rear y-axis chip tray for oil on the base ways.
- 3) Remove either the left or right way cover on the table to check for oil on the X axis ways.

Replacing Way Wipers (Both)

- 1) If the way wipers are damaged, they will need to be replaced.
- 2) Replace damaged way wipers with identical parts only.

Replacing Valve Manifold Assemblies (Both)

- 1) To ensure a valve assembly is replaced with the correct part, use the valve assembly listed in the Fadal Parts Manual, only.
- 2) Loosen each line attached to the manifold. Remove the two attaching bolts of the manifold. Remove the old manifold and install the new manifold using the existing attaching bolts. Insert each line and tighten.

Waylube Pump

Pump Assembly Replacement

- 1) Verify that the machine is in the cold start position. (Both)
- 2) Power off the machine and lock out the main disconnect. (Both)
- 3) Disconnect the air supply line from the machine. (PDI)
- 4) Remove the air fitting from the solenoid. (PDI)
- 5) Remove the oil lines and “Y” fitting from the filter element. (Both)
- 6) Disconnect the wiring to the solenoid and the float switch. (PDI)

- 7) Disconnect the wiring to the motor and the float switch. (Motor)
- 8) Remove the four screws that attach the tank. (Both)

**Caution!**

Tank will come off.

- 9) Remove the waylube pump assembly. (Both)
- 10) Install a new waylube pump assembly and reattach the fitting, “Y” fitting, and oil lines.
- 11) Install tank and fill the oil reservoir with Fadal recommended way lube.
- 12) Connect the wiring to the float switch and solenoid or motor using insulated crimps.
- 13) Reconnect the air supply line. (PDI)
- 14) Manually activate the solenoid to fill the oil lines and filter element assembly. (PDI)
- 15) Manually pump the pump to fill oil lines. (Motor)
- 16) Check for oil and air leaks. (Both)

Pump Electrical Components

The electrical components consist of relays, fuses, float switch wiring, and solenoid wiring.

- 1) The relay and fuse are located on the 1100-2 power distribution board. (Both)
- 2) The float and solenoid wiring are located on the top of pump. (PDI)
- 3) The float and motor wiring are located on top of the pump.

Filter Replacement**LUB-0049 Filter Element, PDI B6 889**

- 1) Disconnect the air supply line from the VMC. (PDI)
- 2) Unscrew the filter element bowl (LUB-0049) and remove the filter. (Both)
- 3) Unscrew the filter. (Motor)
- 4) Install a new filter in the bowl. Fill filter with Fadal recommended way lube oil and reattach the filter element assembly.

- 5) Reconnect the air supply line to the VMC. (PDI)
- 6) Manually activate the system. (Both)
- 7) Check for oil and air leaks. (Both)

Procedure For Flushing Way Lube System

Flushing the way lube system is necessary when the incorrect waylube is installed in the machine. Non-approved waylubes may contain paraffin wax or silicone that cause clogging.

Note: Place plastic bags over the drains of the coolant tank to keep kerosene out of tank.

- 1) Replace the external filter on the Bijur way lube pump. (Both)
- 2) Remove the oil line between the way lube pump and the three port junction T located near the pump mount.
- 3) Verify the flush pump air regulator is fully counterclockwise.
- 4) Flush each line individually. Do not try to flush through PDI injection valve. This will destroy them and the motor meter can be flushed through.
- 5) Attach an air line to the flush pump.

WARNING



Verify that the air regulator is closed.

- 6) Insert the 3/8" hose from the flush pump into a container of grade A kerosene.
- 7) Slowly open the air regulator clockwise to start the flush pump.
- 8) Increase the air pressure; use caution and verify that the output pressure does not exceed 180 psi at the gauge. The pump ratio is 4:1. An input air pressure of 45 psi will produce an output air pressure of 180 psi.
- 9) Enter a program that will exercise all axes to their limits. Start the program running.
- 10) Maintain a constant flow of kerosene through the way lube system.
- 11) If kerosene is found dripping down the column from underneath the Z axis head, the manifold filters are probably clogged. Replace the 8 port junction block located on the Z axis head. Start over at step 4.

- 12) Remove the 3/8" hose from the kerosene and place the hose in a can of clean fresh waylube.
- 13) Slowly open the regulator clockwise on the flush pump. Pump oil through the lines, until the system is well lubricated.
- 14) Stop the machine and return it to the COLD START position.
- 15) Turn the flush pump air regulator fully counterclockwise and remove the air line.
- 16) Remove the flush pump and reattach the oil line from the Bijur pump to the 3 port junction.

Cool Power – Ballscrew / Spindle Cooling System

The purpose of the Cool Power system is to control thermal expansion. This is accomplished by pumping coolant continuously through the ballscrews and spindle. Different models have different cooling configurations.

Note: All temperatures are in Fahrenheit unless stated otherwise.

Electrical Operation

The electrical portion consists of:
 Chiller Controller board (1550-2, PCB-0209)
 Chiller Overload / Relay board (1560, PCB-0046)
 Two or three Temperature Sensors (CNT-0022)
 120 VAC input from the transformer

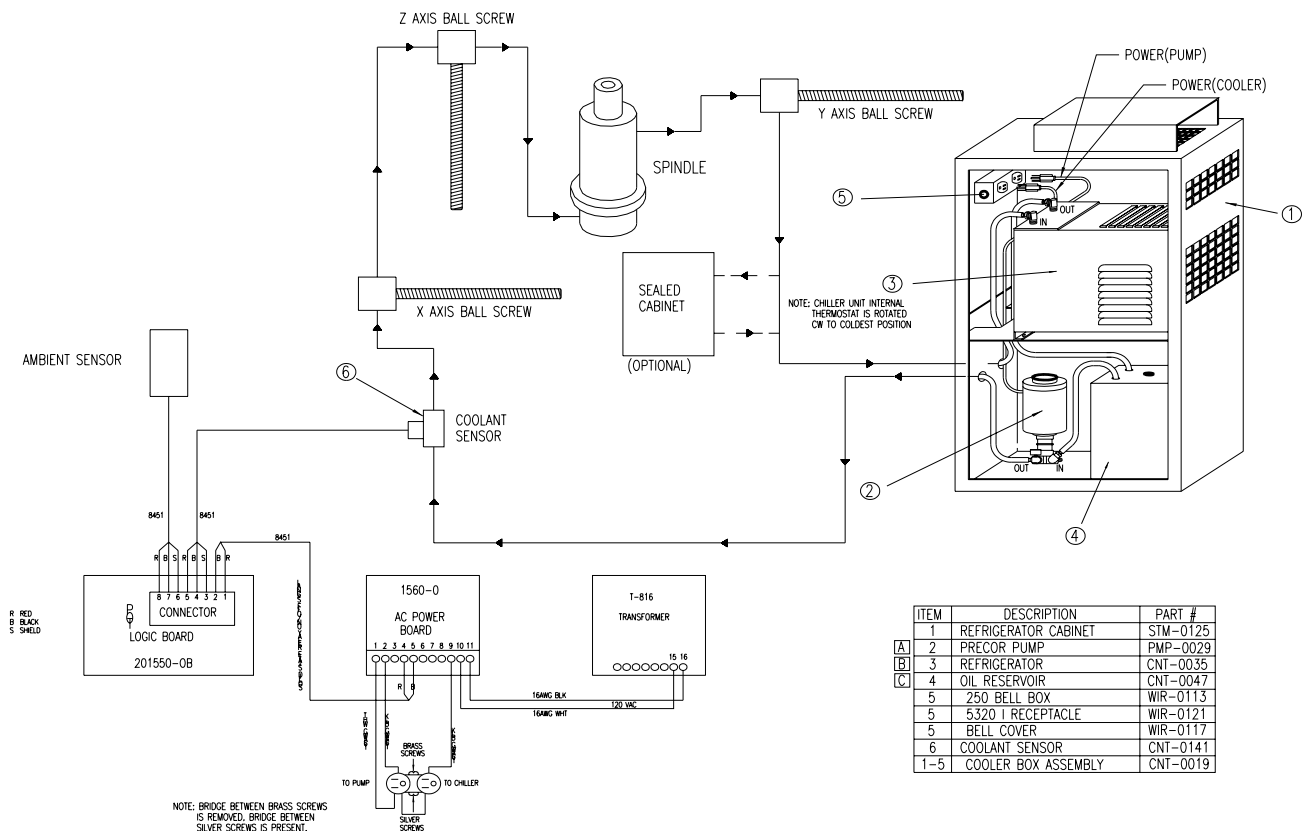

A double 120 VAC outlet (must have the bridge between outlets removed see note)

Chiller Unit

Coolant Pump Motor

Note: 120 VAC output must have the bridge between the brass screws removed. Bridge between silver screws is present.

When the machine is powered on, the coolant pump remains on all the time and the coolant temperature is monitored by a coolant sensor and compared to an ambient sensor. When a difference of one or two degrees is detected the chiller is activated to cool the coolant.

The sensors have three wires, a ground, a reference (REF) voltage and a signal output (ambient or coolant). The sensor circuits on the controller consist of +12 VDC through a resistor to the REF line and signal (ambient or coolant) input line to a resistor and a OP AMP. These circuits compare the ambient to the coolant to determine when the temperatures are different.

If a difference is detected, the chiller controller then activates a solid state relay on the chiller overload / relay board to turn on the chiller. This is accomplished by the controller outputting the +5VDC on pin 1 to the 1560 board pin 4 and connecting to the Solid State Relay (SSR) + control. On pin 2 the controller will pull the line to about zero volts to activate the chiller relay. On the 1560 board the wire is connected to pin 5 of 1560 which is connected to the control on the SSR.

The 120VAC input to the 1560 is on pin 11 and the RET is on pin 10. Both are connected to the transformer. The 120 VAC is routed through a fuse (F1) to two circuit breakers, one (CB1) outputs 120 VAC to the pump motor on pin 1 and the other (CB2) outputs 120 VAC to the contacts of the SSR and when activated outputs to pin 9 which connects to the chiller. The chiller consumes about 2,000 watts for start up and about 500 watts during normal operation.

The current chiller controller is a dual controller; it can operate one or two chillers. On this board J2 is a 8 pin connector and the pins are connected as follows: 1 - +5VDC, 2 – SSR, 3 – Gnd, 4 – Coolant, 5 – REF, 6 – Gnd, 7 – Ambient & 8 – REF.

With the dual chiller configuration, J1 on the controller board is connected to a second 1560 board. The connections are 1550-J1-1 to 1560(2) pin (5 VDC), 1550-J1-2 to 1560(2) pin 5 (SSR), 1550-J1-3 to sensor ground, 1550-J1-4 to sensor signal (coolant) and 1550-J1-5 to sensor REF. **Note:** J2 on the 1550 is CH-1; connect here for a single coolant system and J1 is CH-2; connect here for the second.

The chiller controller board is normally in slot three in the control card cage. It receives the + 5 VDC and + 12 VDC from the backplane but does not communicate to the other boards.

The controller has a heart beat LED to indicate that the board is operational. It also has a test button for each chiller. When the test button is pressed the chiller will run for one minute. There is an LED for each chiller to indicate that it is turned on. There is also an LED for the timer to indicate that the timer is running, a 2.5 minute delay between power up and when the chiller can be activated. This allows the pressure in the chiller unit to decrease to the point where the compressor is able to restart after turned off and immediately power on. A timer button deactivates the timers. If the coolant temperature exceeds 100 degrees, the chiller unit is activated regardless of the ambient temperature. If the coolant temperature falls below 60 degrees the chiller is inhibited.

Older Controller Boards

For older controller boards with adjustable temperature control, the spindle / head must be the same temperature as the base of machine before adjusting. The chiller must be off. Adjust R17 CCW until TEMP LED is off. Turn CW until it comes ON. Find midpoint between on and off.

Coolant flow paths

Different models of the VMC have different coolant configurations.

The configuration, the coolant and the amount of coolant will affect the cooling process. If the tank is full the temperature swings are larger then if the tank is low because more fluid is required to cool and larger temperatures range from top to bottom of the tank.

VMC 15 7,500 RPM Spindle Configuration

No cooling system.

VMC 15 10,000 RPM Spindle or VMC 4020A / 5020A 7,500 RPM Spindle Configuration

Spindle is cooled by flood coolant pumped through the spindle and returned on the base under the saddle.

VMC 2216 / 3016 / 4020 Metric ballscrews, 10,000 RPM Spindle Configuration

The coolant flow path is coolant tank to pump to coolant sensor to X axis ballscrew to Z axis ballscrew to spindle to Y axis ballscrew to chiller and back to coolant tank.

VMC 2216 / 3016 / 4020 Metric ballscrews, 10,000 RPM Spindle, Sealed Cabinet Configuration

The coolant flow path is coolant tank to pump to coolant sensor to X axis ballscrew to Z axis ballscrew to spindle to Y axis ballscrew to cabinet cooler to chiller and back to coolant tank.

VMC 6030 / 8030 10,000 RPM Spindle Configuration

The coolant flow path is coolant tank to pump to spindle to Y axis ballscrew to coolant sensor to chiller and back to coolant tank.

VMC 6030 / 8030 10,000 RPM Spindle, Sealed Cabinet Configuration

The coolant flow path is coolant tank to pump to spindle to Y axis ballscrew to coolant sensor to cabinet cooler to chiller and back to coolant tank.

Motor Couplers

The motor couplers are the connection between the motor and the ballscrew. When replacing the motor or the ballscrew measure the distance from the end of the coupler and the motor or ballscrew. Install the coupler on the new motor or ballscrew and place the coupler back to the same dimension as before. The first couplers were three pronged with a insert disk between them.

A problem when milling a circle was found, the center was off specification as much as .0005 inch (.0127mm) in both X and Y axis. Larger machines may be off more than smaller machines. This has to do with the MTR-0071 Coupler Insert Disk, manufactured of Delrin, deflecting on axis direction change and yielding a small amount of backlash as the castings are reversed in direction.

Couplers, MTR-0154 and MTR-0155, were put in to production to reduce error in backlash. This is a precision coupler with an Aluminum Bronze insert manufactured to within .0001 inch (.0025mm) of tolerance. The Aluminum Bronze material will not deflect nor collapse under these loads, and it provides a bearing to the coupler yokes. These will be shipped as a set of three parts: the ballscrew coupler, the motor coupler, and the Aluminum Bronze insert.

MTR-0154COUPLER SET, ALM BRZ; 5/8

MTR-0155COUPLER SET, ALM BRZ; 7/8

MTR-0154 is intended to fit all machines that use GTK GM4050 or Reliance motors, and MTR-0155 is intended to fit all machines with the larger GTK GM6000, and AC drive motors.

No lubrication is necessary on these couplers, but the installation procedure is important. Use caution to prevent any nicks or bumps to the Aluminum Bronze Disk.

- 1) Remove old coupler components.
- 2) Install new coupler onto ballscrew, measuring from face of Ballscrew Bearing mount to coupler pocket.
- 3) Install coupler onto motor, measuring from face of motor flange to coupler pocket.
- 4) Insert Aluminum Bronze Disk onto Ballscrew Coupler, making certain not to gouge or burr the edges, and aligning the two lobes horizontally to retain the disk.
- 5) Install the motor, using SVT-0122 Motor Alignment Guides, and bolt in place.
- 6) Check to be certain that the maximum gap between the Coupler lobe and the Disk pocket is .070 inch (1.8mm), and the minimum is .050 inch (1.27mm).

- 7) Operate the machine and check for Motor axis to Ballscrew axis alignment. Re-center motor under the 4 bolts to reduce Coupler Insert Disk runout, to prevent premature wear.

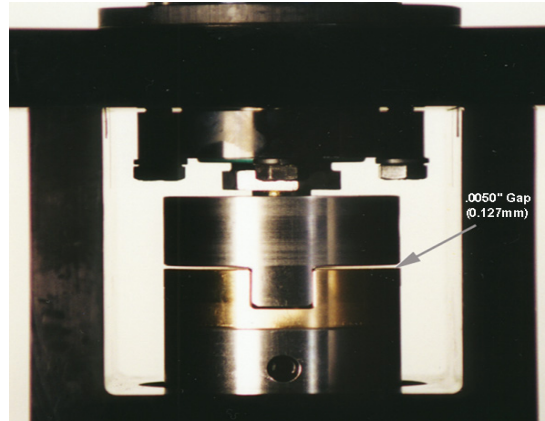

Figure 6-3 These couplers will provide an audible “click” if the axis is jogged back and forth. This is normal.

Report clanking noise in axis, vibrations and slamming in G0 moves, ballbar analysis discrepancies, backlash problems, misposition problems, and premature wear of couplers.

Aluminum Bronze disk style couplers wear down, and clearances between components result in one or more of the symptoms described above.

A new type of Bellows Coupler, made with a stainless steel bellows and bonded between two aluminum mounts is currently being installed. The Bellows enables the Motor shaft centerline to drive the Ballscrew and flex slightly if any mismatch in alignment exists, thus eliminating moving components.

Installation may be required:

- 1) For VMCs 6535, 4525 and 3020 on X-Axis, remove the 3 screws mounting the first way cover section to the table, and slide it back to view the motor and coupler. Remove Motor Cover.
- 2) For VMCs 6535, 4525 and 3020 Y-Axis, remove the rear hood from the Y-Axis cover, and slide forward when Y is at positive limit.
- 3) Remove motor and old coupler.
- 4) Install the new Bellows Coupler tight against the Ballscrew jam nut.
- 5) Using a 5 mm Allen wrench, tighten the Coupler bolt to 20 Foot-Pounds (15 N-M).

- 6) Using SVT-0122 Motor Alignment Guide Rods, slide the Motor into the Mount and Coupler.
- 7) Tighten the Coupler Bolt as above.



Figure 6-4 MTR-0189 Coupler, Bellows; 7/8 Shaft. MTR-0190 Coupler, Bellows; Siemens.

Gib Adjustment**IMPORTANT**

DO NOT rush gib adjustments—they are critical! Do not adjust any gibs unless the machine is leveled properly.

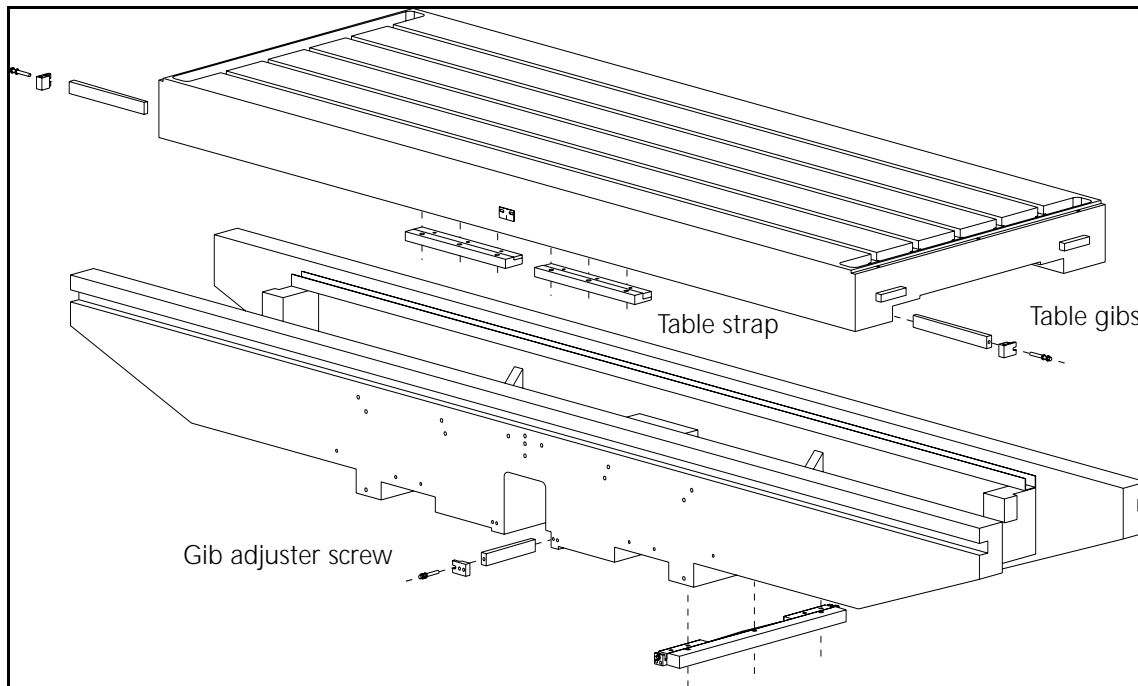

Figure 6-5 Gib Adjustments

There are two gibs at the front of the table and from 4 to 6 Gib/Strap assemblies on the underside of the table (depending on the VMC model, see Figure 6-1). The following procedure covers adjustment of the front table gibs. There are two front gibs, one on the left and one on the right. This adjustment procedure is applicable for all VMC models.

- 1) Center the table at the X-axis cold start position. Attach a magnetic base and an indicator just below the gib, as shown in Figure 6-7. Adjust and set at a zero reading.

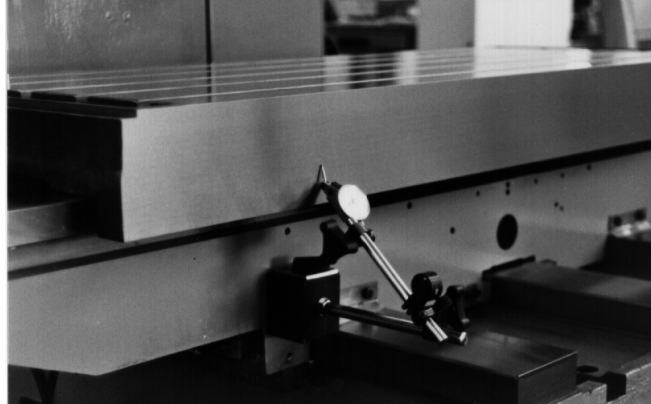

Figure 6-6 Attach Magnetic Base and Indicator

- 2) Place a pry bar between the front table gib/strap assembly and the saddle.
- 3) With the pry bar, move the table forward so the solid rear way of the table is against the saddle.
- 4) Zero the indicator.
- 5) Place the pry bar between the rear table gib/strap assembly and the saddle.
- 6) Gently pry the table the opposite way.
- 7) The indicator reading is the adjustment that needs to be made. A properly adjusted set of gibs will have a front to back motion of .0003".
- 8) If the gib needs adjusting, there is a gib adjuster screw located at the end of the gib. Turning this screw clockwise will loosen the gib and turning it counter clockwise will tighten the gib.
- 9) Repeat the above steps until a .0003" indicator motion is achieved. Then, perform the procedure over again for the gib at the opposite end.

After both gibs have been completely adjusted, run the table to its extremes at the plus and minus ends and then return the table back to center. Then, repeat the above gib adjustment procedure for verification.

**Table Gib/Strap
Assembly**

When adjusting gibs with shim stock, use extreme care to prevent ripping the shim and leaving pieces of it between the gib and way surfaces.

There are gib/strap assemblies on the underside of the table at the front and rear. Depending on the model of VMC there will be from one to three gib/strap assemblies at the front and at the rear.

Adjust the gib/strap assembly as follows:

- 1) Jog the table in the X-axis to clear the cold start indicator.
- 2) Loosen the three hex head bolts. The slot for the bolt is tapered. When the gib is moved, the head of the bolt may bind. Verify that the bolt is loosened enough to allow the gib to slide from left to right.
- 3) Slide the gib to the right to loosen the gib. The gib must be loosened first before it can be tightened. To move the gib, use an open end wrench or a hex head and tap with a mallet.
- 4) To adjust, slide the gib to the left (operator orientation is facing the strap) until it contacts the underside of the saddle. Use finger pressure to push the gib.
- 5) Verify that each of the three hex head bolts are not caught in the tapered slot. If the bolts are binding on the slot, loosen and re-adjust the bolts.
- 6) Tighten the three hex head bolts.
- 7) Repeat the above steps for the opposite table gib/strap assembly.

Saddle Gibs There are two gibs to the right of the center base rail and two gib/strap assemblies on the underside of the saddle. The following procedure covers adjustment of the center saddle gibs only. The following adjustments apply to all VMC models. It may be necessary to remove the rear Y-axis tray to adjust the saddle gibs.

- 1) Center the saddle to the Y-axis cold start position. Attach the magnetic base and indicator to the saddle. Position the indicator as shown in Figure 6-8. Set the indicator to zero.

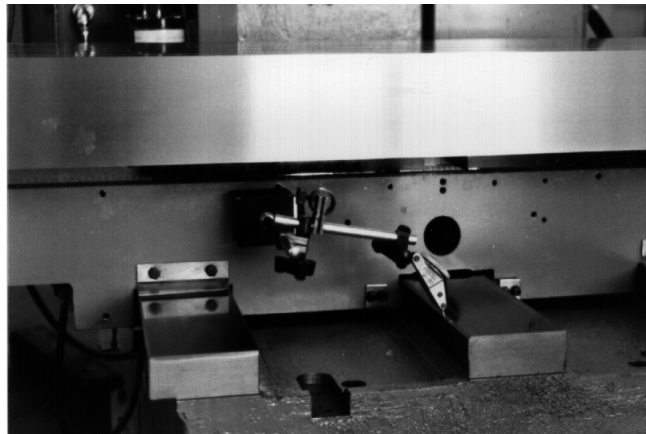

Figure 6-7 Position Indicator

- 2) Standard machines: Place a pry bar between the right saddle gib/strap assembly and the base.
- 2) Performance Models: Place a pry bar between the X axis ballscrew mount and the table.
- 3) With the pry bar, move the saddle so the solid way of the saddle makes contact with the center base rail.
- 4) Zero the indicator.
- 5) Standard machines: Place the pry bar between the left saddle gib/strap assembly and base.
- 5) Performance models: Place the pry bar between the other side of the X axis ballscrew mount of the table.
- 6) Gently pry the saddle the opposite way.
- 7) The indicator reading specifies the amount that the gib should be adjusted. A properly adjusted set of gibs will have a side to side motion of .0003".

- 8) If the gibs need adjusting, there is a gib adjuster screw located at the end of each gib. Turning this screw clockwise will loosen the gib and counter clockwise will tighten the gib.
- 9) Repeat the above steps, until .0003" indicator motion is achieved, then adjust the gib at the opposite side.

After the gib adjustments are complete, run the saddle to its extremes at the plus and minus end and then back to center again. Then, repeat the above gib adjustment procedure for verification.

Saddle Gib/Strap Assembly

When adjusting gibs with shim stock, use extreme care to prevent ripping the shim and leaving pieces of it between the gib and way surfaces.

There is one gib/strap assembly on the left side of the saddle and one on the right. Each gib/strap assembly has two gibs that require adjustment. Adjust the saddle gib/strap assembly as follows:

- 1) Loosen both the front and back gibs on the strap by turning the gib adjuster screw clockwise.
- 2) Insert a .001" shim about three to four inches between the gib and the way. Place shims in both the front and rear at the same time.
- 3) Tighten the gib to pinch the shim between the gib and way by turning the gib adjuster screw counter clockwise. Tighten the screw enough to prevent the shim from moving.
- 4) Slowly turn the gib adjuster screw clockwise while pulling on the shim.



WARNING

Shim stock is very sharp!

- 5) When the shim starts pulling out, stop turning the gib adjuster screw and remove the shim completely.
- 6) Turn the gib adjuster screw 3/4 turn counter-clockwise.
- 7) Repeat the above steps for the front, rear, left, and right gibs.

Head Gibs There are two gibs that ride between the column ways, one at the top and one at the bottom. See Figure 6-9. There is also one gib/strap assembly on the back of each column rail (the 3020 and 4525 have two gib/strap assemblies on each way).

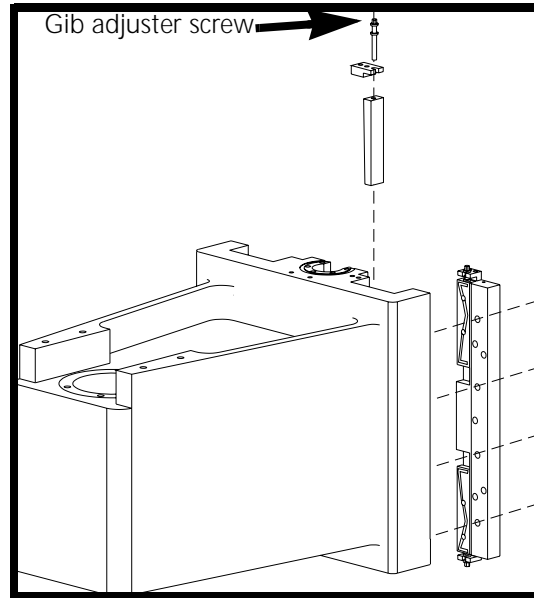

Figure 6-8 Gib Strap Assemblies on Spindle Head

- 1) Remove the Z axis head cover.
- 2) Center the Z axis head within its travel limits so it will be easy to work on.
- 3) Attach a magnetic base and indicator to the column, as shown in Figure 6-10.

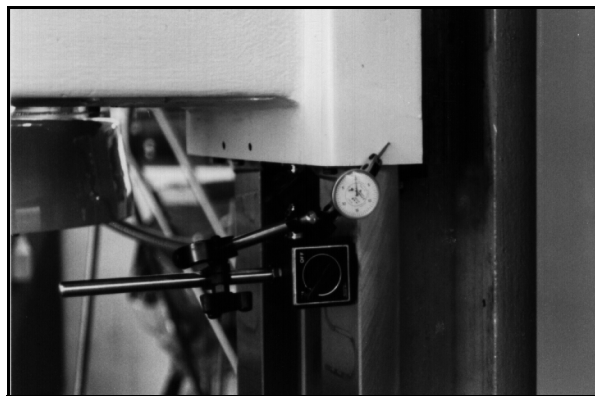

Figure 6-9 Magnetic Base and Indicator Mounting on Spindle Head

- 4) Using a pry bar between the left side of the head and Z-axis way, move the head so the inside of the left way contacts the left column way.

- 5) Zero the indicator.
- 6) Place the pry bar between the right side of the head and Z-axis way.
- 7) Gently pry the head the opposite way.
- 8) Make adjustments according to the indicator reading. A properly adjusted Z-axis head gib is .0002' to .0003" motion side to side.
- 9) If the gibs need adjusting, there is a gib adjuster screw located at the end of each gib. Turning this screw clockwise loosens the gib and counter clockwise tightens the gib.
- 10) Repeat the above steps, until indicator motion is .0002" to .0003", then adjust the gib at the opposite side.

After both gib adjustments are complete, run the head to its extremes at the plus and minus end and then back to center again. Then, repeat the above gib adjustment procedure for verification.

Head Gib/Strap Assembly

When adjusting gibs with shim stock, use extreme care to prevent ripping the shim and leaving pieces of it between the gib and way surfaces.

There is one gib/strap assembly at the left and right side of the head. Each gib/strap assembly has a top and bottom gib that requires adjusting. Adjust the head gib/strap assembly as follows:

- Top Gibs**
- 1) Loosen all four gibs by turning the gib adjuster screws clockwise.
 - 2) Insert a .001" shim, approximately 3" to 4" long, between the column and the Z-axis head. Do both the left and right sides.
 - 3) Tighten the gib, to pinch the shim between the head and way, by turning the gib adjuster screw counter clockwise. Tighten the gib enough to prevent the shim from moving.
 - 4) Slowly turn the gib adjuster screw clockwise while pulling on the shim.



WARNING

Shim stock is very sharp!

- 5) When the shim starts to pull out, stop turning the gib adjuster screw and remove the shim, completely.
- 6) Do the same for the other side.

7) Turn both gib adjuster screws one turn counter-clockwise after the shims have been removed from the left and right sides.

Bottom Gibs

8) Insert a .001" shim about 3" to 4" long between the rear of the column way and the bottom gib. Do the same for left and right sides.

9) Tighten the gib to pinch the shim between the gib and way by turning to the gib adjuster screw counter clockwise. Tighten the gib enough to prevent the shim from moving.

10) Slowly turn the gib adjuster screw clockwise while pulling on the shim.

**WARNING**

Shim stock is very sharp!

11) When the shim starts pulling out, stop turning the gib adjuster screw and remove the shim completely.

12) Do the same for the other side.

13) Turn both gib adjuster screws one turn counter clockwise after the shims have been removed from the left and right sides.

6535/4525/3020 Gib & Strap Adjustments

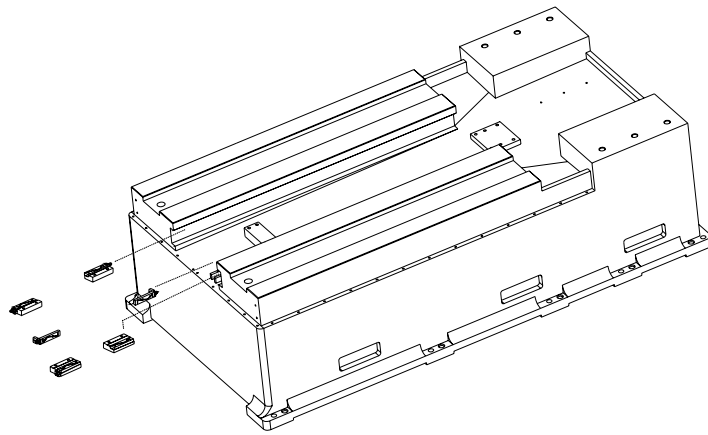

Figure 6-10 Base: gib & strap location.

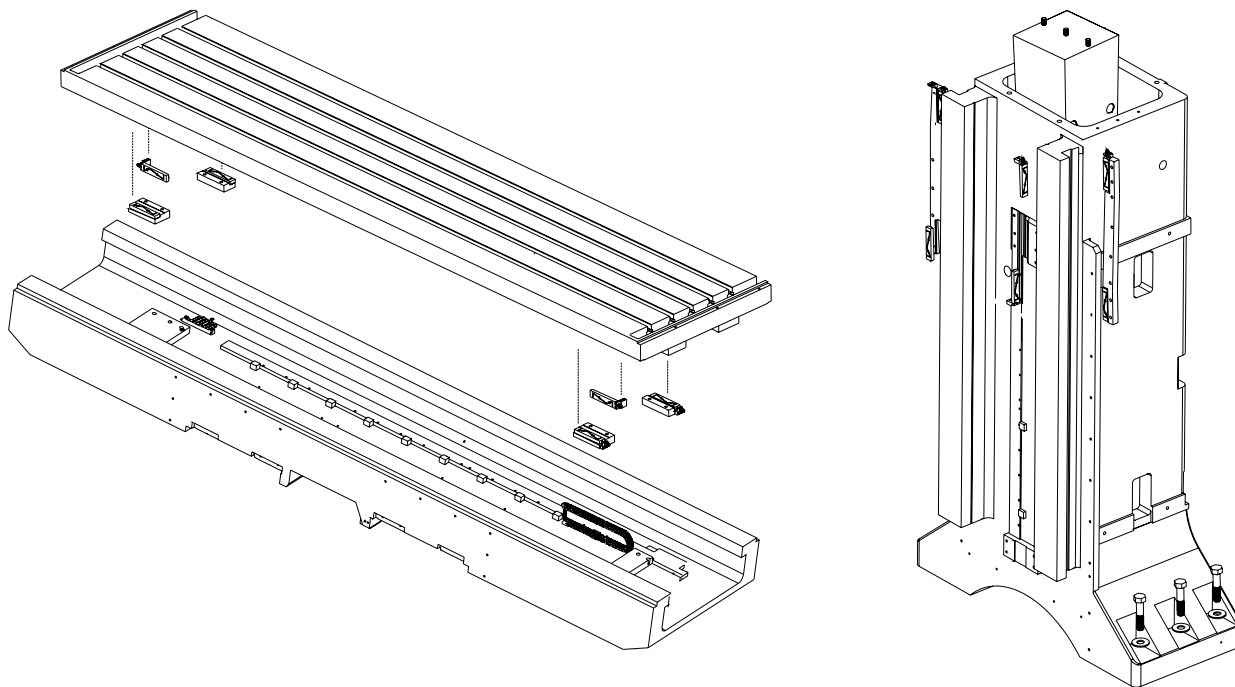

Figure 6-11 Saddle & column: strap & gib location.

Table Gibs

There are two (2) gibs at the front of the table and four (4) GIB/STRAP assemblies on the underside of the table. The following steps describe how to adjust the front table gibs. There is one at the left and one at the right.

- 1) With the table centered at the X axis cold start position:
 - a. Attach a magnetic base and indicator just below the gib to be adjusted, and set a zero reading.



Figure 6-12 Set Zero Reading

- b. Place a pry bar between the X axis ballscrew mount and the table.
- c. With the pry bar, move the table forward so the solid rear way of the table is up against the table.
- d. Zero the indicator.
- e. Now place the pry bar between the other side of the X axis ballscrew mount and the table.
- f. Gently pry the table the opposite way.
- g. The indicator reading is the adjustment that needs to be made. A properly adjusted set of gibs will have front to back motion of $.0003$ (+/- $.0001$).
- h. If the gibs need adjusting, there is a gib adjuster screw located at the end of each gib. Turning this screw clockwise will loosen the gib and counter clockwise tighten the gib.

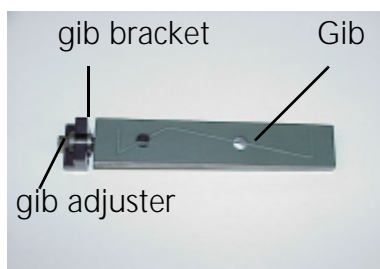

Figure 6-13 Gib Adjustment

- i. Repeat the above steps until you get $.0003$ indicator motion, and then go to the other gib at the opposite end. **Note:** If the gibs are more than a $.0010$ " out of adjustment, then adjust one side to about $.0009$ " and

repeat on the opposite end. Repeat the steps to .0003". This is to avoid maladjustment due to binding.

After both gibs have been completely adjusted run the table to its extremes at the plus and minus end and then back to center again. Then repeat the above gib adjustment procedure for verification.

Table Gib/Strap Assembly



WARNING

Shim Stock is very sharp. Handle with care.

When adjusting gibs with shim shock be very careful not to cause the shim to rip and leave a piece between the gib and way surface. There are GIB/STRAP assemblies on the underside of the table at the front and rear. There will be two (2) GIB/STRAP assemblies at the front and rear. The front straps are wider than the rear straps. Adjust the table GIB/STRAP assembly as follows:

- 1) Loosen both the front and back gibs on the strap by turning the gib adjuster screw clockwise.
- 2) Insert a .001" shim about 3-4" between the gib and the way. Place shims in both the front and rear at the same.
- 3) Tighten the gib to pinch the shim between the gib and the way by turning the gib adjuster screw counter clockwise. Tighten the gib enough to prevent the shim from moving.
- 4) Slowly turn the gib adjuster screw clockwise while pulling on the shim.
- 5) When the shim begins to pull out, stop turning the gib adjustment screw and remove the shim completely.
- 6) Turn the gib adjuster screw 3/4 turn counterclockwise.
- 7) Repeat the above steps for the front, rear, left and right gibs.

Saddle Gibs



WARNING

Shim Stock is very sharp. Handle with care.

There are two (2) gibs on the inside of the right rail on the base and two (2) GIB/STRAP assemblies on the underside of the saddle on each side to the inside of the rails. The GIB/STRAP assemblies are wider on the right side to

allow space for the gibs. It will be necessary to remove the way covers to adjust the gibs.

- 1) With the saddle centered at the Y axis cold start position, attach a magnetic base and indicator to the saddle and place the indicator near the gib to be adjusted.
- 2) Place a pry bar between the saddle and the outside of the base rail.
- 3) With the pry bar, move the saddle so the solid way of the saddle contacts the inside of the left base rail.
- 4) Zero the indicator.
- 5) Now place the pry bar between the saddle and the outside of the base rail.
- 6) Gently pry the saddle the opposite way.
- 7) The indicator reading is the adjustment that needs to be made. A properly adjusted set of gibs will have a side to side motion of .0003".
- 8) If the gibs need adjusting, there is a adjuster screw located at the end of each gib. Turning this screw clockwise will loosen the gib and counter clockwise will tighten the gib.
- 9) Repeat the above steps until you get .0003" indicator motion, then adjust the other gib on the opposite side.

After both gibs have been completely adjusted run the saddle to its extremes at the plus and minus end and then back to center again. Then repeat the above gib adjustment procedure for verification.

When adjusting gibs with shim stock be very careful not to cause the shim to rip and leave a piece between the gib and way surface. There are GIB/STRAP assemblies on the underside of the saddle at the front and back of both sides. The right side straps are wider than the left side straps.

Adjust the saddle GIB/STRAP assembly as follows:

- 1) Loosen both the front and back gibs on the straps by turning the gib adjustment screw clockwise.
- 2) Insert a .001" shim about 3-4" between the gib and the way. Place shims in both the front and back at the same time.
- 3) Tighten the gib to pinch the shim between the gib and the way by turning the gib adjuster screw counter clockwise. Tighten the gib enough to prevent the shim from moving.

- 4) Slowly turn the gib adjuster screw clockwise while pulling on the shim.
- 5) When the shim begins to pull out, stop turning the gib adjuster screw and remove the shim completely.
- 6) Turn the gib adjuster screw $3/4$ turn counterclockwise.
- 7) Repeat the above steps for the front, rear, left and right gibs.

Head Gibs

**WARNING**

Shim Stock is very sharp. Handle with care.

There are two (2) gibs that ride between column ways on the right side, one at the top and one at the bottom. There is also two (2) GIB/STRAP assemblies on the back of each column rail. The center gibs are adjusted in this section. Either gip can be adjusted first.

- 1) Remove the Z axis head cover.
- 2) Center the Z axis head within its travel limits so it will be easy to work on.
- 3) Attach a magnetic base and indicator to the column, as shown in Figure 6-13.

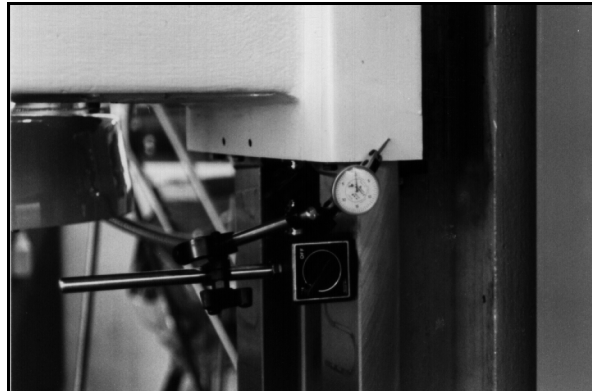

Figure 6-14 Attach Magnetic Base and Indicator to Column

- 4) Using a pry bar between the left side of the head and Z-axis way, move the head so the inside of the left way contacts the left column way.
- 5) Zero the indicator.
- 6) Place the pry bar between the right side of the head and Z-axis way.
- 7) Gently pry the head the opposite way.
- 8) Make adjustments according to the indicator reading. A properly adjusted Z-axis head gip is .0002' to .0003" motion side to side.
- 9) If the gibs need adjusting, there is a gip adjuster screw located at the end of each gip. Turning this screw clockwise loosens the gip and counter clockwise tightens the gip.

- 10) Repeat the above steps, until indicator motion is .0002" to .0003", then adjust the gib at the opposite side.

After both gib adjustments are complete, run the head to its extremes at the plus and minus end and then back to center again. Then, repeat the above gib adjustment procedure for verification.

Head Gib/Strap



WARNING

Shim Stock is very sharp. Handle with care.

When adjusting gibs with shim stock be very careful not to cause the shim to rip and leave a piece between the gib and way surface. There are two (2) GIB/STRAP assemblies top and bottom on both sides, left and right. The two (2) top and the two (2) bottom must be adjusted together.

Top Gib/Strap

- 1) Loosen all four (4) gibs by turning the gib adjuster screws clockwise .
- 2) Insert a .001" shim about 3-4" long between the column and the Z axis head, be sure the shim is in the center of the way. Do the same for the left and right side.
- 3) Tighten the gib to pinch the shim between the head and way by turning the gib adjuster screw counterclockwise. Tighten enough to prevent the shim from moving.
- 4) Slowly turn the gib adjuster screw clockwise while pulling on the shim.
- 5) When the shim begins to pull out, stop turning the gib adjuster screw and remove the shim completely.
- 6) Do the same for the other side.
- 7) Turn both gib adjuster screws one (1) turn counterclockwise after the shims have been removed from the left and the right.

Bottom Gib/Strap

- 8) Insert a .001" shim about 3-4" long between the rear of the column way and the bottom gib. Do the same for the left and right side.
- 9) Tighten the gib to pinch the shim between the gib and the way by turning the gib adjuster screw counterclockwise. Tighten enough to prevent the shim from moving.
- 10) Slowly turn the gib adjuster screw clockwise while pulling on the shim.

- 11) When the shim begins to pull out, stop turning the gib adjuster screw and remove the shim completely.
- 12) Do the same for the other side.
- 13) Turn both gib adjuster screws one (1) turn counterclockwise after the shims have been removed from the left and the right side.

**SQUARENESS TEST:
(Measures
Squareness from X
to Y)**

- 1) Level Machine.
- 2) Adjust TABLE, SADDLE and HEAD GIBS. Set for Turcite gibs: .0003" Non-Turcite gibs: .0005".
- 3) Adjust TABLE, SADDLE and HEAD STRAP GIBS.
- 4) The above items must be properly set or the SQUARENESS TEST may be invalid.
- 5) Using a granite plate, zero indicator at point A (front left position on plate) and make a 10.000 inch move in X axis from point A to point B (front right position on plate). Using MDI mode enter "X10.0 F50. G1."
- 6) Take a reading at point B. If not zero, adjust the granite plate for a zero reading.
- 7) Repeat steps 5 and 6 until both A and B positions read zero.
- 8) Zero indicator at point C (front of right side position on plate) and make a 10.000 inch move in Y axis from point C to point D (back of the right side of the plate). Using MDI enter "Y10.0 F50. G1."
- 9) Record reading at D. This is the squareness value, and it should be within .0006 inch.

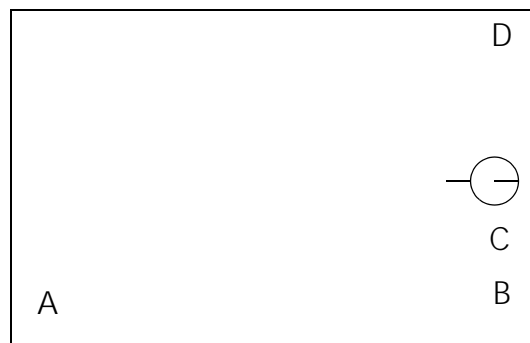
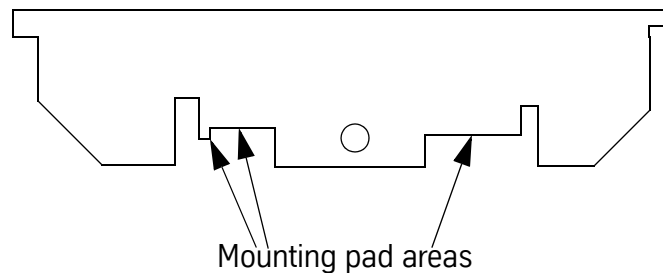

Figure 6-15 Granite Plate (top view)

**Installing VMC
Linear Way Saddle**

- 1) Level machine ways.
- 2) Clean way mounting pads.
- 3) Position mounting pads for saddle.
- 4) Position grease line couplers upward.
- 5) Install safety stop to rail.
- 6) Stone saddle at mounting pad areas and clean.



- 7) Install saddle assembly to mounting pads, slowly lower and check pad position and grease line couplers as installing.

Note: Check several times when lowering the saddle.

- 8) Install mounting pad bolts (5/16-18 X 1" long so-cap) and leave loose.
- 9) Tighten set screws, double check for tightness.
- 10) Tighten mounting pads.
- 11) Install Y axis ball screw assembly.
- 12) Install Y axis limit stop assembly.
- 13) Remove table teleflex covers.
- 14) Jog table to the left and Install Y axis grease lines.
- 15) Jog table to the right and Install Y axis grease lines.
- 16) Install table teleflex covers.

Procedure for Correcting the Saddle Squareness

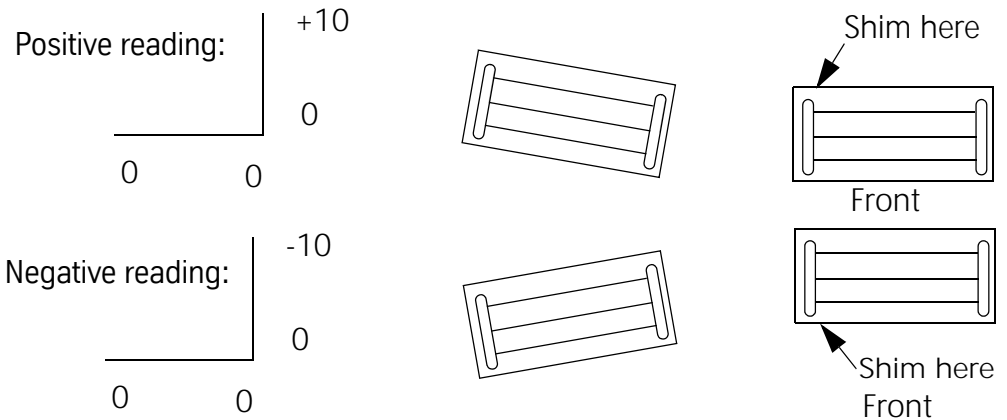

- 1) Shim size is error size. Example $.0007 - .0012 = .001$ shim
 $.0013 - .0017 = .0015$ shim
- 2) Loosen mounting bolts.
- 3) Loosen set screws.
- 4) Loosen Y axis ball screw at column.
- 5) Pry saddle away from mounting pad area (hard stop).
- 6) Install shim (between pad and hard stop) and pry saddle to mounting pad.
- 7) Tighten set screws, double check tightness.
- 8) Tighten mounting pad bolts.
- 9) Align Y axis ball screw and tighten.
- 10) Check plate reading.

Procedure for Correcting the Table Squareness

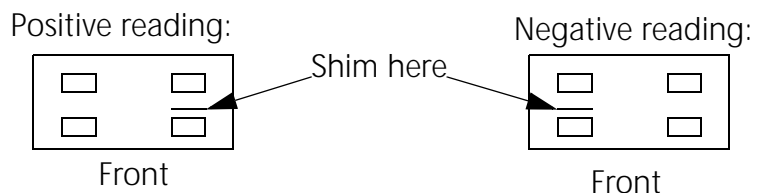

- 1) Shim size is error divided by 1.7.
- 2) Remove front and rear table covers.
- 3) Loosen mounting pad bolts to table.

- 4) Loosen set screws.
- 5) Loosen X axis ball screw nut at table block.
- 6) Pry table away from mounting pad area (hard stop).
- 7) Install shim (between pad and hard stop) and pry table to mounting pad.
- 8) Tighten set screws, double check tightness.
- 9) Tighten mounting pad bolts.
- 10) Align X axis ball screw nut and tighten.
- 11) Install front and rear table covers.
- 12) Check T-slot reading.

Axis Limit Stops

TRM & EMC X, Y, Z Axis

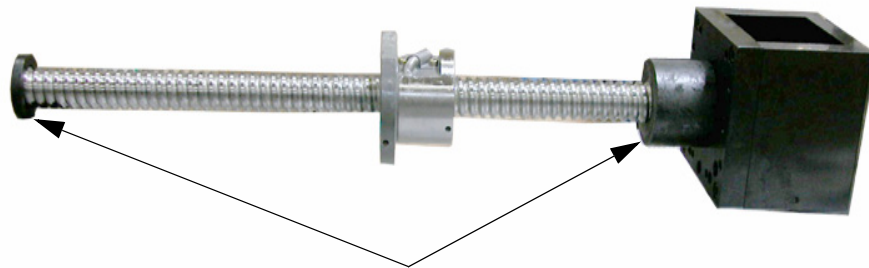

EMC ballscrew limit stops

Figure 6-16 EMC ballscrew with limit stops.

No adjustment is needed for the EMC or TRM ballscrew limit stops. Each is created to the exact dimension needed to prevent an axis from traveling beyond it's intended range.

Mechanical Y Axis

- 1) Position the saddle to its positive limit.

- 2) Go to the rear of the column and locate the limit bar.

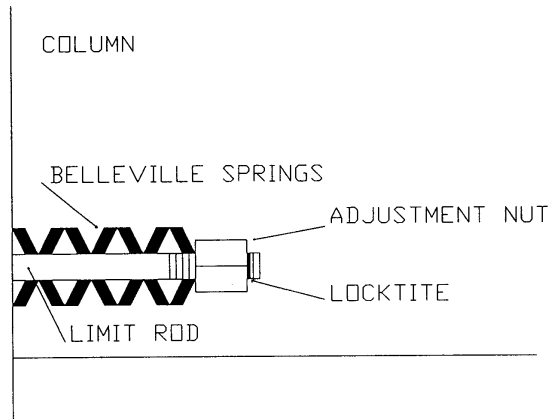

Figure 6-17 Locate Limit Bar at Rear of Column

- 3) Tighten the adjustment nut until there is no play between the Belleville springs, but loose enough so the springs will rotate.
- 4) After adjusting, use blue Locktite on the nut.
- 5) Position the saddle to its negative extreme.
- 6) Go to the front of the column and locate the limit bar.

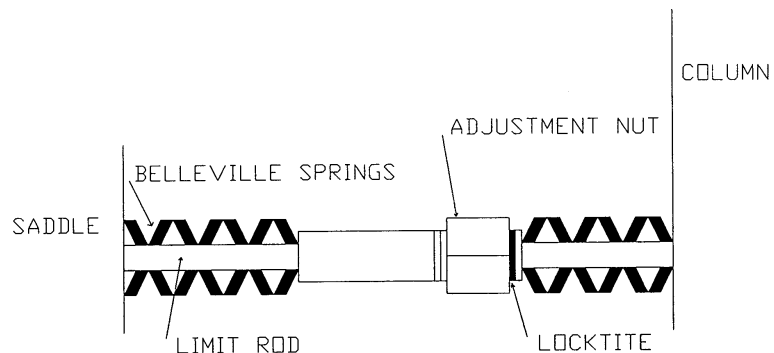

Figure 6-18 Locate Limit Bar at Front of Column

- 7) Tighten the adjustment nut until there is .25 gap between the Belleville springs and the column.
- 8) After adjusting, use blue Locktite on the nut.

Backlash

For VMCs equipped with the PDI waylube pump, turn the power to the pump off and on. JOG the axis that is being inspected a few inches back and forth to ensure the ways of the machine are riding on a film of oil.

Backlash Parameter Description

Backlash parameter values allow the control to compensate for the physical limitations of the ball screw when changing tool direction. Values are entered in tenths (ten-thousandths of an inch). The control stores three values for the X-axis and the Y-axis (at center, at negative limit, at positive limit) and one value for each of the Z, A, and B axes (at center).

Note: Values are NOT stored for axes not installed on a given machine.

Entering Backlash Values

Backlash values are entered into the control using the BL command. The format of the command is:

BL, a, b, c, d

where a = axis number (X=1, Y=2, Z=3, A=4, B=5)

b = compensation (in tenths) at center

c = compensation (in tenths) at negative limit (X and Y axes only)

d = compensation (in tenths) at positive limit (X and Y axes only)

Typing BL <ENTER> (that is, without values) will display currently stored values.

Determining Proper Backlash Values

There are several methods for determining the correct value(s) of each axis. The programmatic method described here is the most reliable.

The following is an example of a programmatic method for determining the three backlash values for the X-axis. The same applies to Y-axis, just substitute Y for X. For Z-axis replace Z values with X and X values with Z. The value determined (i.e., center, negative limit, or positive limit) depends on the tool location on the axis (see STEP 3).

- 1) Enter the cold start command CS <ENTER>. After the cold start, DO NOT return to the last home position.

- 2) From the command mode, clear the current backlash values for the X axis by typing BL,1,0,0,0 and pressing the ENTER button.

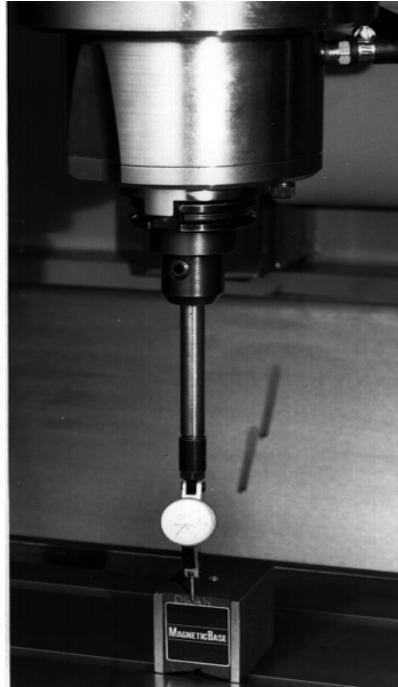

Figure 6-19 Establish a Zero Reading

- 3) Place a surface indicator in a tool holder and JOG the needle to Z-.1 and X.1 from the X-positive side of a block in the center of the table. The face of the indicator should be toward the right side (X-positive) side of the machine. From the command mode, type SETH and press the ENTER button.
- 4) Insert the following program into memory:

```
N1 G91 G1 X-.1 F (See note below)
N2 G4 P66000
N3 Z.25 G5
N4 X-.1
N5 X.1
N6 Z-.25
N7 G4 P66000
N8 X.1
N9 M2
```

Note: For part programs requiring close tolerances, setting the feed rate in line N1 to match the feed rate of the part program to be run will maximize the accuracy of the backlash values.

- 5) Run the program in the following manner:
 - a. At line N2 the control will be in the waiting state. Adjust the dial of the surface indicator to zero on the needle, then press the START button to continue.
 - b. At line N7 the control will be in the waiting state. Read the indicator dial to see how many tenths the needle is away from zero.
 - c. Press the START button followed by the MANUAL button.
 - d. Enter the number determined in step b as the backlash value (see ENTERING BACKLASH VALUES above).
 - e. Repeat steps a through c and verify that the indicator now reads zero after step c. If not, adjust the backlash value entered in step d. Continue this process until the indicator consistently reads zero after step c.
- 6) Repeat step 4, placing the block at the negative limit of the X axis. Repeat step 5 to determine the negative limit value.
- 7) Repeat step 4, placing the block at the positive limit of the X axis. Repeat step 5 to determine the negative limit value.

Note: When entering the value for the negative limit, you MUST enter at least a comma for the at-center value; when entering the value for the positive limit, you MUST enter at least a comma for both the at-center and the negative-limit values. For example, to set a value of 5 tenths (.0005) for the negative limit of the Y axis without affecting the current value for the center, type BL,2,,5, ENTER ; to set a value of 3 tenths (.0003) for the center and 2 tenths (.0002) for the positive limit on the X axis without affecting the current value for the negative limit, type BL,1,3,,2, ENTER.

- 8) The home position was set with the indicator tip close to an edge. Before continuing with other operations, the home position must be reset.
 - a. From the command mode, type SETCS and press the ENTER button.
 - b. Type HO and press the ENTER button, followed by the START button.
 - c. After the axes return to the cold start position, type SETH and press the ENTER button.