

TABLE OF CONTENTS

Parts Manual VMC 3020 MODEL



COLUMN ASSEMBLY	2
10K HEAD ASSEMBLY	4
BASE ASSEMBLY	6
SADDLE ASSEMBLY	8
DRAWBAR ASSEMBLY	10
ORIENTATION BRIDGE ASSEMBLY	11
IDLER ASSEMBLIES	12
WAYLUBE ASSEMBLY	14
DUAL ARM TOOL CHANGER	15
10K RPM SPINDLE ASSEMBLY	16
COOLANT THRU SPINDLE	17
CNC CABINET ASSEMBLY	18
CARD CAGE ASSEMBLY	19
JUNCTION BOX ASSEMBLY	20
CE CNC CABINET ASSEMBLY	21
CE JUNCTION BOX ASSEMBLY	22
MP PENDANT ASSEMBLY	23
88HS PENDANT ASSEMBLY	24
COOLANT TANK ASSEMBLY	25
SHEETMETAL ASSEMBLY	27

This reference covers the following Fadal products:

Model VMC 3020

Corporate Office	voice (818) 407-1400	fax (818) 407-0020
Service / Parts	voice (818) 727-2100	fax (818) 407-1004
Programming Support	voice (818) 727-2100	fax (818) 407-0061

support@fadal.com

20701 Plummer Street Chatsworth California 91311 U.S.A.

The content of this manual has been reviewed for accuracy and is applicable to current Fadal hardware and software products as described herein. Differences may exist and we cannot guarantee that they are completely covered in this document. The information in this document is reviewed regularly and any necessary changes will be incorporated in the next revision. We welcome any suggestions for improvement.

Material is subject to change without notice.

This manual is for the exclusive use of Fadal Customers and Distributors. The reproduction, transmission or use of this document or its contents is not permitted without the expressed written permission of Fadal Machining Centers. All rights, including rights created by patent grant or registration of a utility, model or design, are reserved.

© Copyright 2001 Fadal Machining Centers.

COLUMN ASSEMBLY

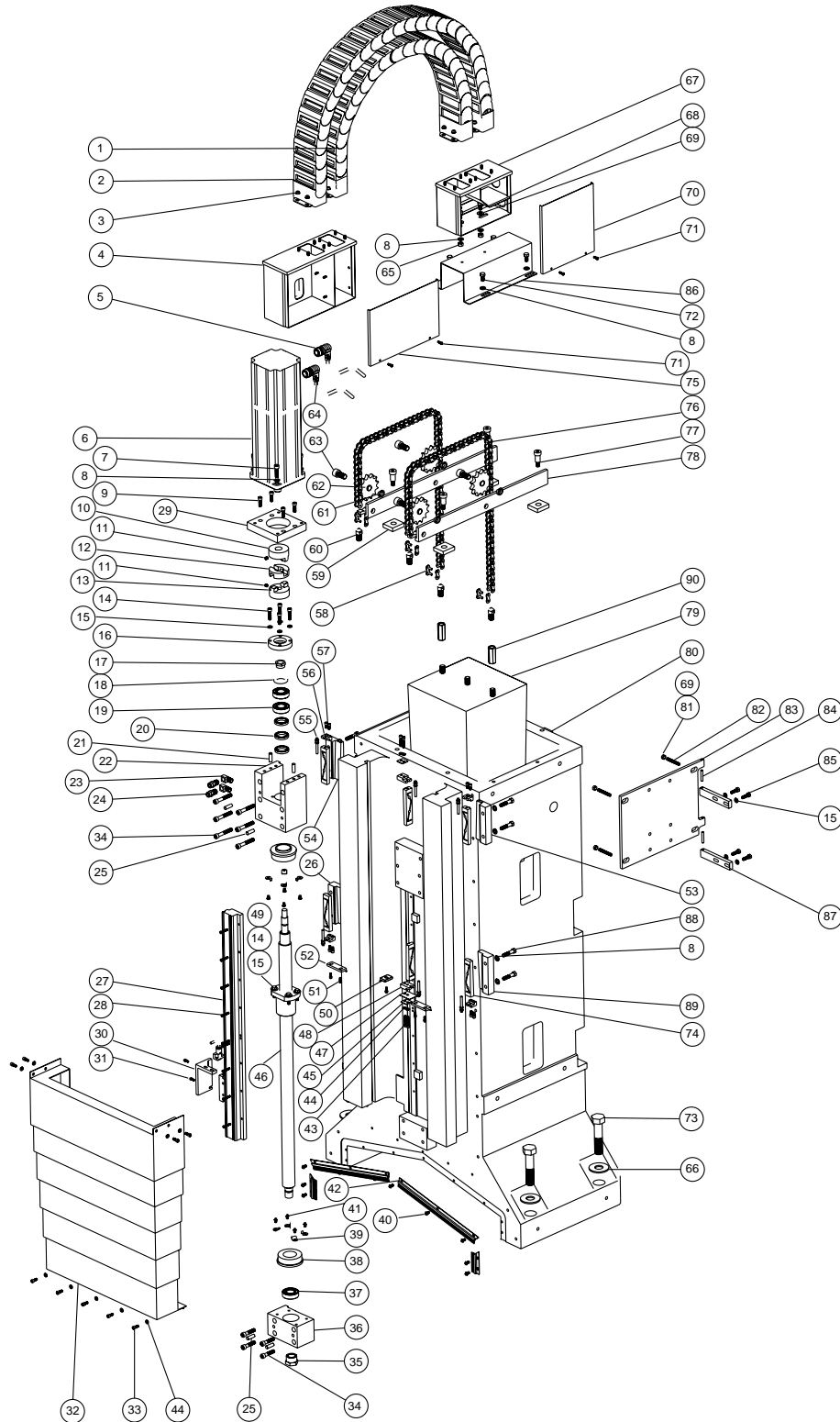

COLUMN ASSEMBLY

COLUMN ASSEMBLY

	PART #		PART #		PART #		PART #
1	CVR-0106	26	GIB-0025	51	HDW-1016	76	HDW-0999
2	CVR-0107	27	SCL-0089	52	CVR-0123	77	HDW-0600
3	HDW-0337	28	HDW-0797	53	GIB-0029	78	CWT-0025
4	STM-0301	29	BLS-0245	54	GIB-0030	79	CWT-0020
5	WIR-0611	30	SCL-0086	55	GIB-0013	80	COL-0026
6	MTR-0142	31	HDW-0090	56	GIB-0012	81	HDW-0640
7	HDW-0779	32	CVR-0117	57	HDW-0295	82	HDW-0952
8	HDW-0280	33	HDW-0346	58	HDW-0204	83	STM-0705
9	HDW-0481	34	HDW-0474	59	HDW-0363	84	HDW-0330
10	MTR-0158	35	BLS-0049	60	CWT-0001	85	SHDW-0314
11	HDW-0419	36	BLS-0246	61	CWT-0021	86	STM-0919
12	MTR-0156	37	BRG-0022	62	PUL-0034	87	HDW-0931
13	MTR-0157	38	BLS-0197	63	HDW-0777	88	HDW-0569
14	HDW-0315	39	STM-0905	64	WIR-0612	89	GIB-0026
15	HDW-0281	40	HDW-0295	65	HDW-0333	90	HDW-0335
16	BLS-0240	41	HDW-0347	66	HDW-1010		
17	BLS0047	42	CVR-0110	67	STM-0334		
18	HDW-0210	43	HDW-0296	68	HDW-0562		
19	BRG-0024	44	HDW-0279	69	HDW-0049		
20	HDW-0213	45	STM-0042	70	STM-0335		
21	HDW-0619	46	BLS-0200	71	HDW-0633		
22	BLS-0247	47	HDW-0355	72	HDW-0576		
23	PLM-0073	48	GIB-0010	73	HDW-1019		
24	PLM-0088	49	PLM-0034	74	GIB-0001		
25	HDW-0330	50	CVR-0128	75	STM-0300		

10K HEAD ASSEMBLY

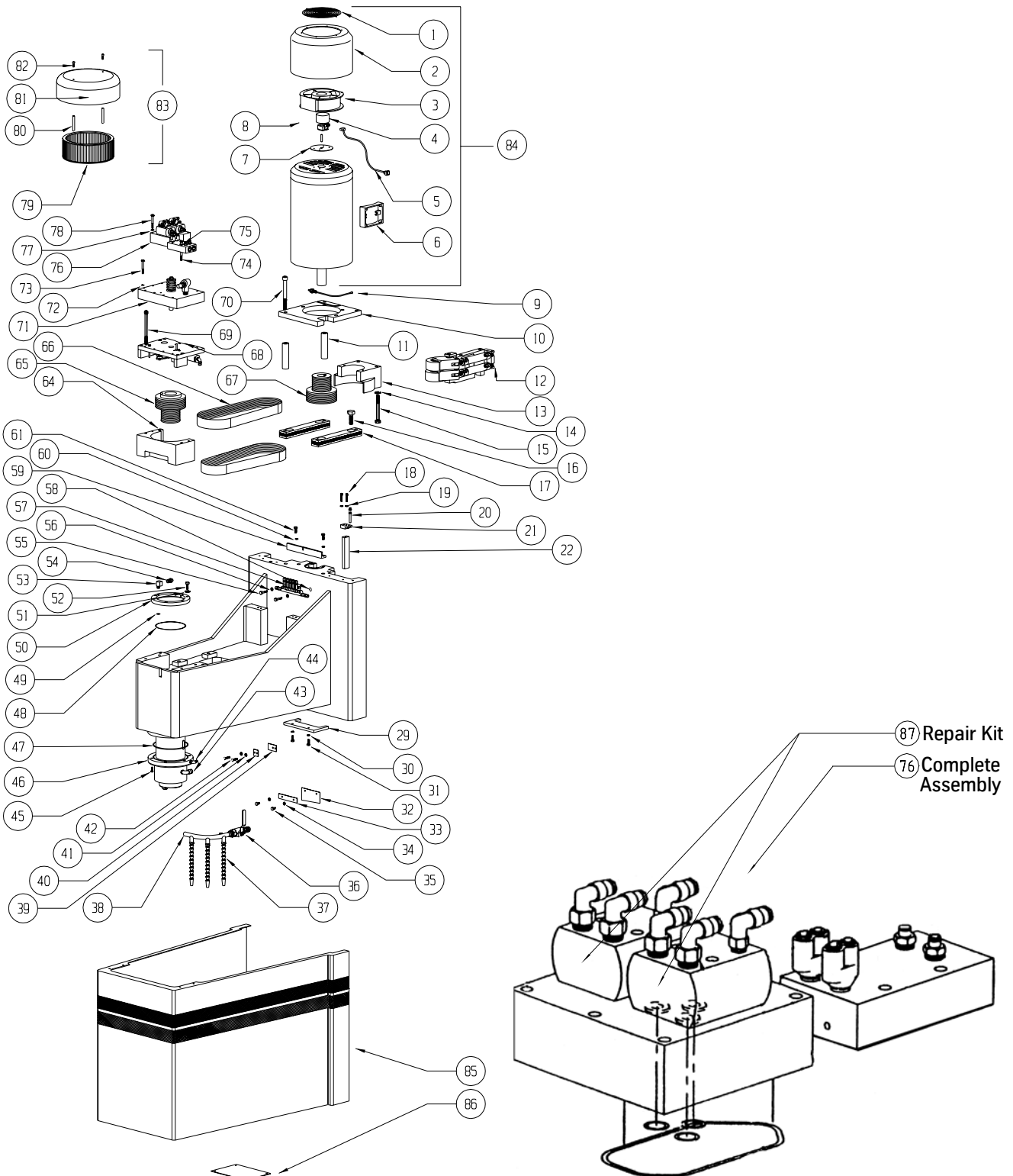

10K HEAD ASSEMBLY

10K HEAD ASSEMBLY

	PART #		PART #		PART #
1	HDW-0851	30	HDW-0279	59	STM-0142
2	STM-0139	31	HDW-0322	60	HDW-0279
3	ELE-0124	32	HDW-0356	61	HDW-0322
4	MTR-0123	33	STM-0052	62	
5	WIR-0168	34	HDW-0279	63	
6	MTR-0059	35	HDW-0319	64	BEL-0014
7	STM-0148	36	VLV-0017	65	PUL-0018
8	ENC-0007	37	PLM-0016	66	BEL-0003
9	HDW-0370	38	CNT-0039	67	PUL-0019
10	MTR-0069	39	HDW-0355	68	ORB-0001
11	MTR-0149	40	STM-0042	69	HDW-0290
12	IDL-0003	41	HDW-0279	70	HDW-0284
13	BEL-0015	42	HDW-0294	71	DRB-0000
14	HDW-0451	43	PLM-0112	72	HDW-0279
15	HDW-0311	44	PLM-0034	73	HDW-0320
16	HDW-0283	45	HDW-0470	74	HDW-0321
17	MTR-0068	46	SPN-0008 ⁽²⁾	75	HDW-0279
18	HDW-0294	47	HDW-0181	76	HYD-0017
19	HDW-0279	48	HDW-0148	77	HDW-0279
20	GIB-0013	49	HDW-0177	78	HDW-0320
21	GIB-0010	50	SPN-0042	79	MTR-0127
22	GIB-0001 ⁽¹⁾	51	HDW-0275	80	SVT-0108
23		52	HDW-0568	81	STM-0467
24		53	PLM-0075	82	HDW-0597
25		54	PLM-0088	83	MTR-0128
26		55	HDW-0576	84	MTR-0047
27		56	HDW-0279	85	STM-0888
28		57	LUB-0045	86	STM-0064
29	CVR-0048	58	HDW-0047	87	HYD-0018

⁽¹⁾SPN-0008 Includes: HDW-0181, HDW-0177, HDW-0148, PUL-0018

⁽²⁾Specify gib size when ordering.

BASE ASSEMBLY

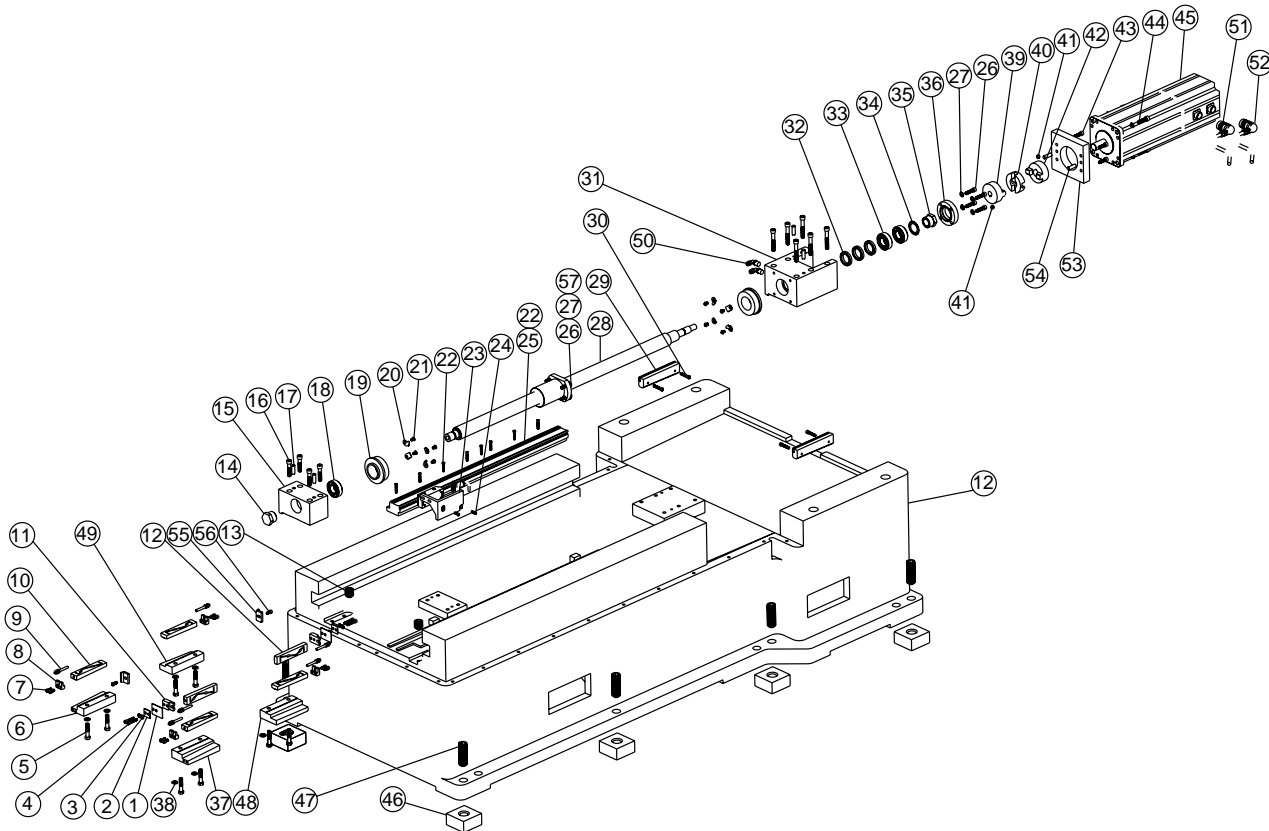

BASE ASSEMBLY

	PART #		PART #		PART #		PART #
1	HDW-0355	16	HDW-0474	31	BLS-0247	46	PLC-0063
2	STM-0042	17	HDW-0330	32	HDW-0213	47	HDW-0432
3	HDW-0279	18	BRG-0022	33	BRG-0024	48	GIB-0028
4	HDW-0296	19	BLS-0197	34	HDW-0210	49	GIB-0025
5	HDW-0569	20	STM-0905	35	BLS-0047	50	PLM-0112
6	GIB-0026	21	HDW-0347	36	BLS-0240	51	WIR-0663
7	HDW-0295	22	HDW-0797	37	GIB-0027	52	WIR-0664
8	GIB-0012	23	SCL-0085	38	HDW-0280	53	BLS-0245
9	GIB-0013	24	HDW-0090	39	MTR-0157	54	HDW-0619
10	GIB-0001	25	SCL-0088	40	MTR-0156	55	CVR-0128
11	GIB-0010	26	HDW-0315	41	HDW-0419	56	HDW-1016
12	BAS-0020	27	HDW-0281	42	MTR-0158	57	PLM-0034
13	HDW-0434	28	BLS-0199	43	HDW-0481		
14	BLS-0049	29	CVR-0114	44	HDW-0779		
15	BLS-0246	30	HDW-0296	45	MTR-0142		



This page intentionally left blank.



SADDLE ASSEMBLY

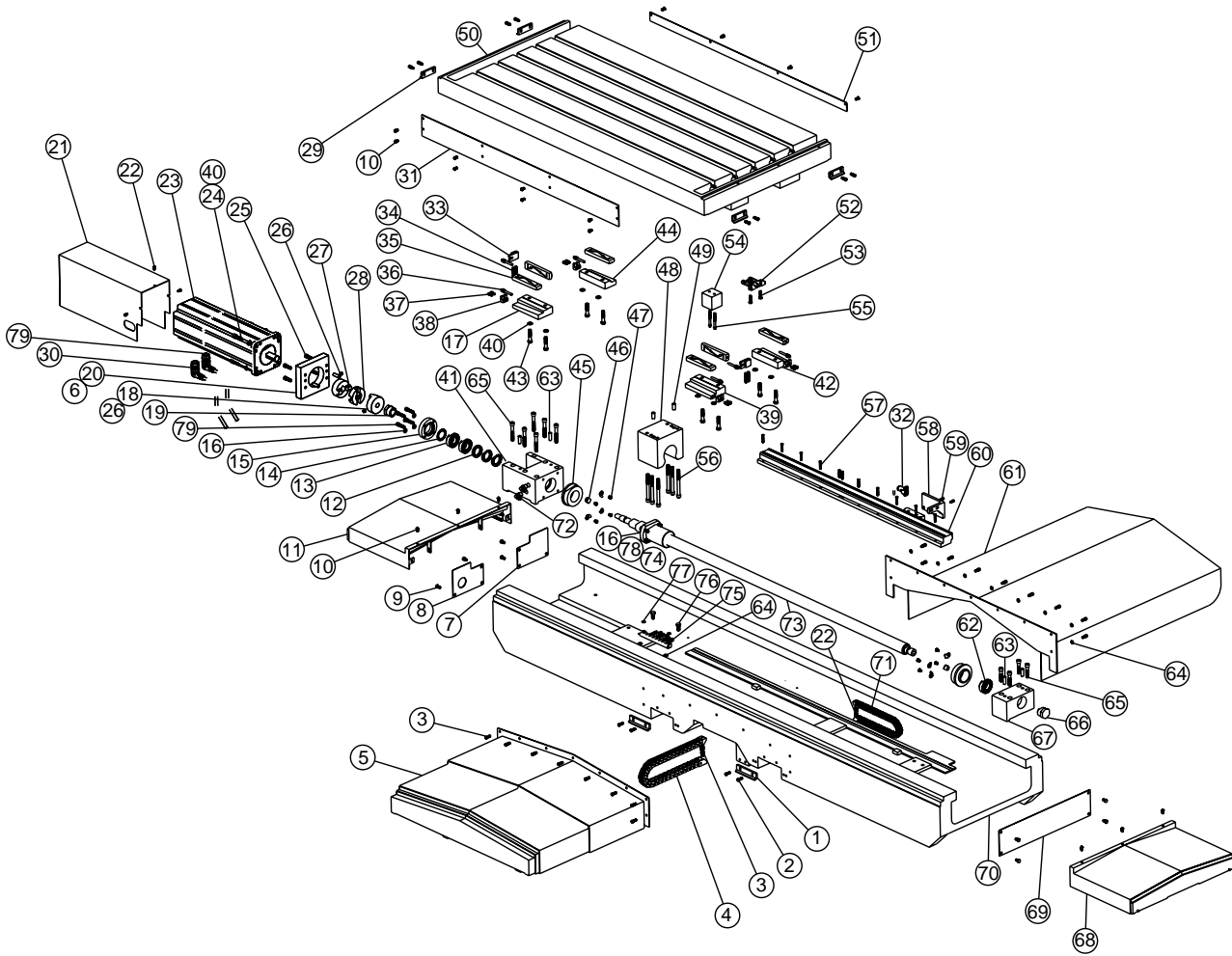

SADDLE ASSEMBLY

SADDLE ASSEMBLY

	PART #		PART #		PART #		PART #
1	CVR-0122	23	MTR-0142	45	BLS-0197	67	BLS-0246
2	HDW-1016	24	HDW-0779	46	STM-0905	68	CVR-0120
3	HDW-0581	25	HDW-0481	47	HDW-0347	69	CVR-0112
4	CVR-0116	26	HDW-0419	48	BLS-0244	70	SDL-0050
5	CVR-0118	27	MTR-0158	49	HDW-0622	71	CVR-0115
6	HDW-0619	28	MTR-0156	50	TBL-0029	72	PLM-0112
7	CVR-0121	29	CVR-0124	51	STM-0917	73	BLS-0198
8	CVR-0113	30	WIR-0676	52	LUB-0044	74	PLM-0034
9	HDW-0319	31	STM-0906	53	HDW-0318	75	LUB-0043
10	HDW-0346	32	SCL-0031	54	SCL-0084	76	HDW-0576
11	CVR-0119	33	GIB-0001	55	HDW-0489	77	HDW-0047
12	HDW-0213	34	HDW-0296	56	HDW-0477	78	HDW-0281
13	BRG-0024	35	GIB-0001	57	HDW-0797	79	WIR-0677
14	HDW-0210	36	GIB-0013	58	SCL-0085		
15	BLS-0240	37	HDW-0295	59	HDW-0090		
16	HDW-0315	38	GIB-0012	60	SCL-0025		
17	GIB-0027	39	GIB-0028	61	CVR-0125		
18	MTR-0157	40	HDW-0280	62	BRG-0022		
19	BLS-0047	41	BLS-0247	63	HDW-0330		
20	BLS-0245	42	GIB-0025	64	HDW-0279		
21	CVR-0126	43	HDW-0569	65	HDW-0474		
22	HDW-0349	44	GIB-0026	66	BLS-0049		

DRAWBAR ASSEMBLY

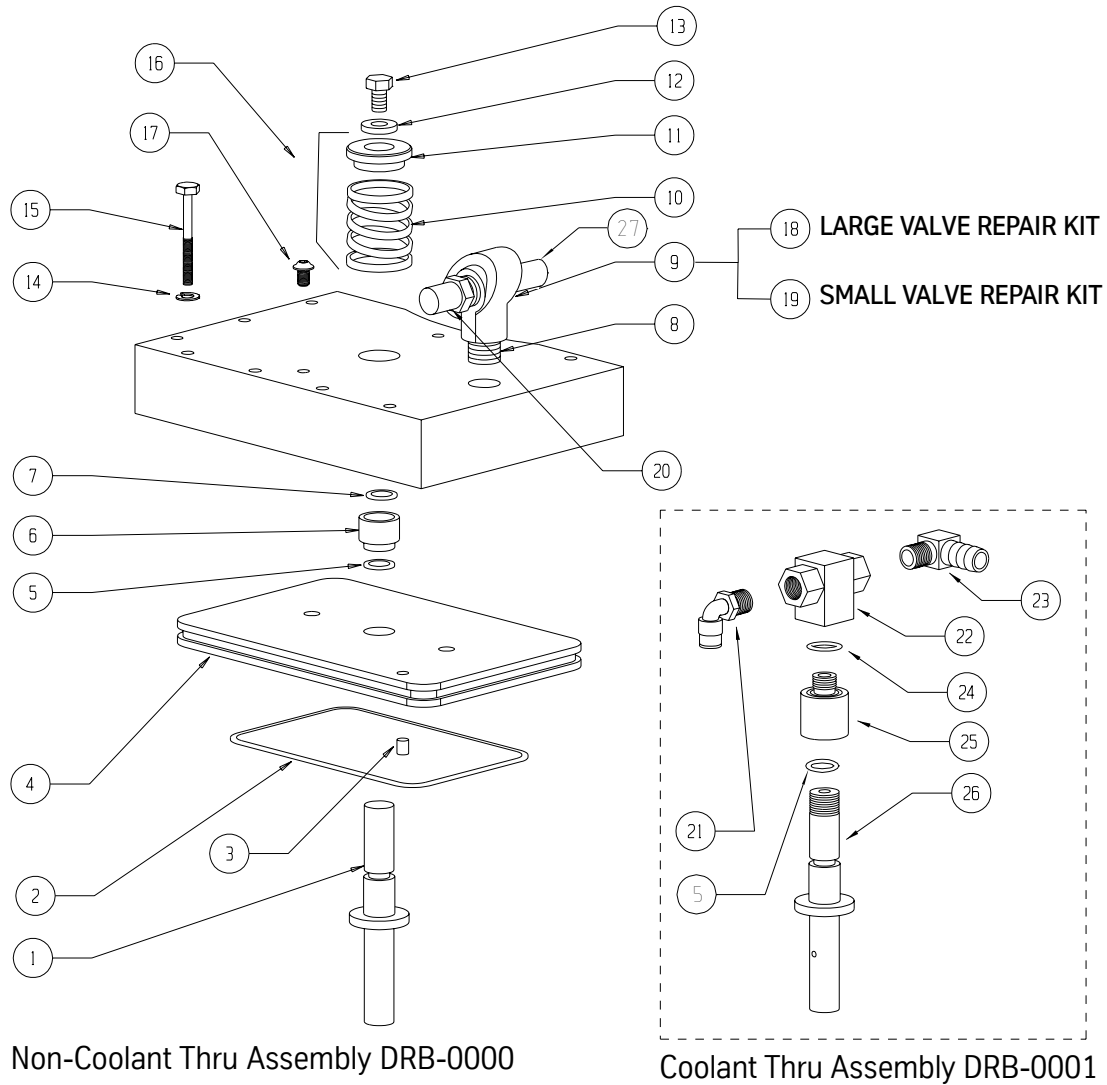

DRAWBAR CYLINDER ASSEMBLIES

	PART #		PART #		PART #		PART #
1	DRB-0007	8	PLM-0117	15	HDW-0320	22	VLV-0021
2	HDW-0178	9	VLV-0031	16	HDW-0197	23	PLM-0105
3	ELE-0147	10	HDW-0262	17	HDW-0347	24	HDW-0150
4	DRB-0009 ⁽¹⁾	11	DRB-0017	18	VLV-0032	25	CNT-0046
5	HDW-0177	12	HDW-0048	19	VLV-0033	26	DRB-0008
6	DRB-0023	13	HDW-0575	20	PLM-0083	27	PLM-0030
7	HDW-0917	14	HDW-0279	21	PLM-0037		

¹Includes ELE-0147

ORIENTATION BRIDGE ASSEMBLY

ORB-0001

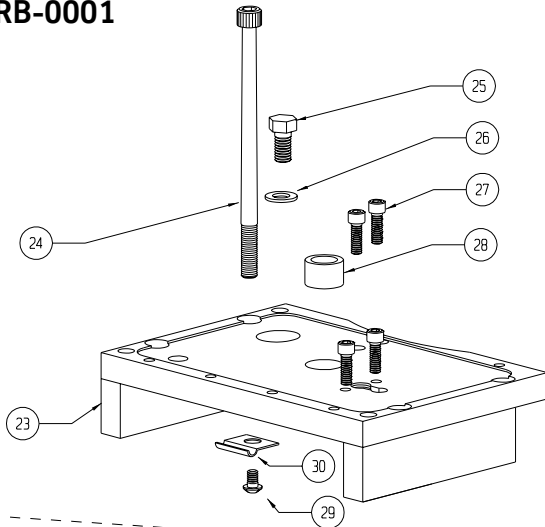

ORB-0002

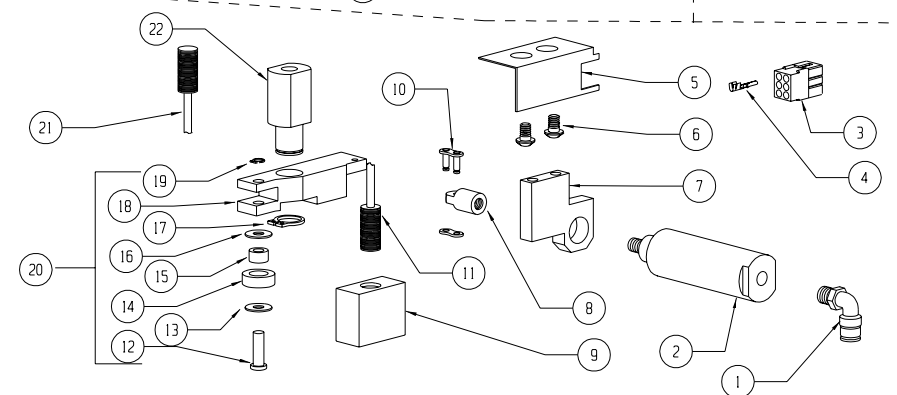
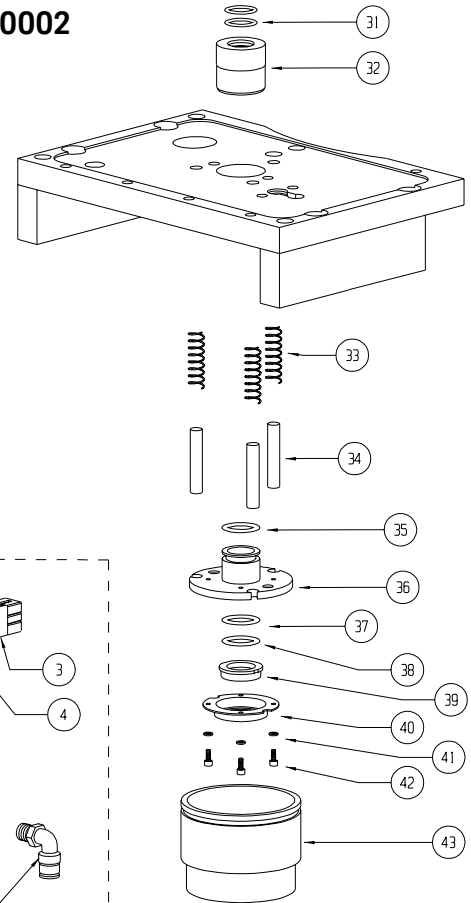

COMMON TO BOTH VERSIONS

ORIENTATION BRIDGE ASSEMBLIES

	PART#		PART#		PART#		PART#		PART#
1	PLM-0034	8	ORB-0011	18	ORB-0031	28	BRG-0008	38	HDW-0156
2	CYL-0007	9	ORB-0014	19	HDW-0726	29	HDW-0349	39	CNT-0033
3	WIR-0051	10	HDW-0209	20	ORB-0004	30	LUB-0077	40	CNT-0045
4	WIR-0043 (16 AWG)	11	ELE-0145	21	ELE-0145	31	HDW-0150	41	HDW-0453
	WIR-0044 (16 AWG)	12	ORB-0007	22	ORB-0013	32	CNT-0042	42	HDW-0308
	WIR-0544 (22 AWG)	13	HDW-0515	23	ORB-0008	33	HDW-0257	43	CNT-0140
	WIR-0056 (22 AWG)	14	ORB-0009	24	HDW-0285	34	HDW-0326		
5	STM-0596	15	BRG-0014	25	HDW-0571	35	HDW-0156		
6	HDW-0347	16	HDW-0515	26	HDW-0048	36	CNT-0041		
7	ORB-0030	17	HDW-0725	27	HDW-0298	37	HDW-0155		

IDLER ASSEMBLIES

RIGID TAP/HIGH TORQUE OPTION

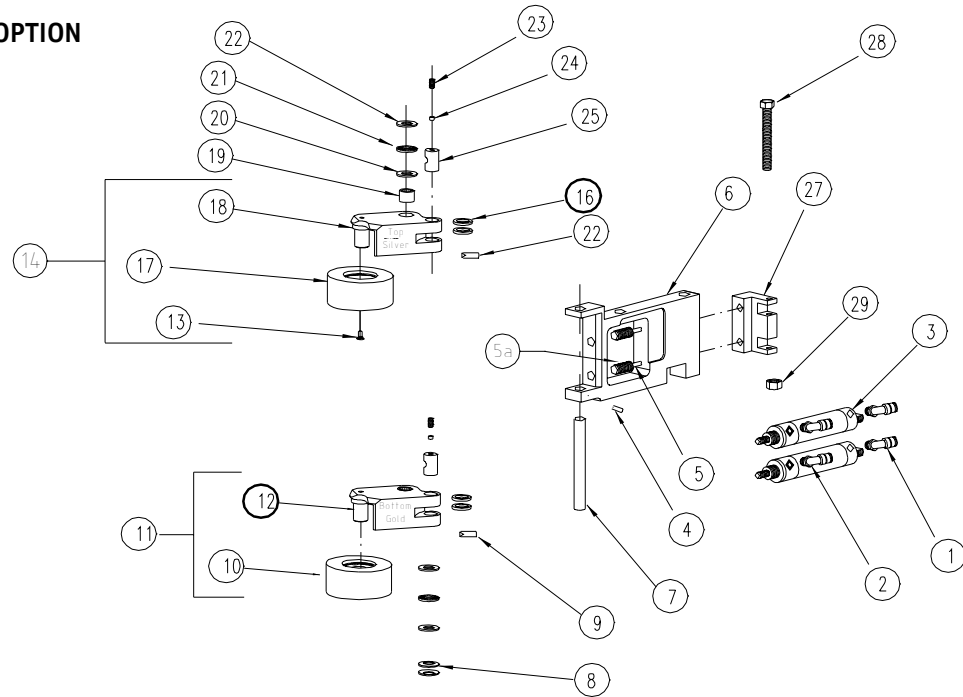

10,000 RPM OPTION

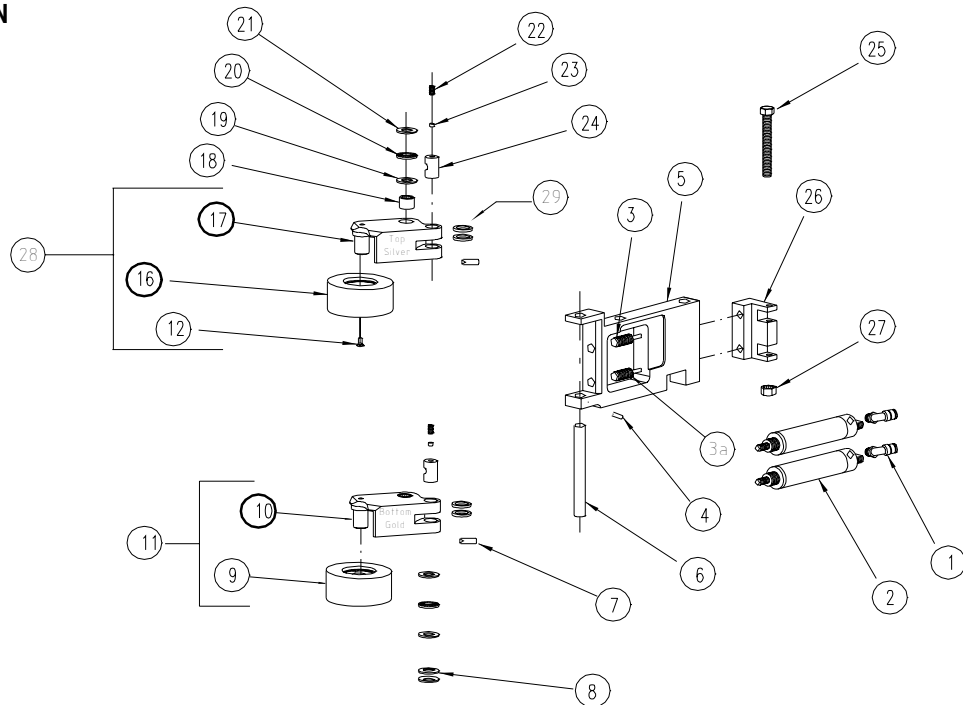

IDLER ASSEMBLIES

RIGID TAP/HIGH TORQUE OPTION

	PART #		PART #		PART #
1	PLM-0034	10	BRG-0058	21	BRG-0015
2	PLM-0034	11	IDL-0000	22	ELE-0147
3	CYL-0005	12	IDL-0004	23	HDW-0412
4	HDW-0612	13	HDW-0412	24	IDL-0010
5	ELE-0145	14	IDL-0018	25	IDL-0012
5a	ELE-1202	16	HDW-0277		
6	IDL-0011	17	BRG-0058	27	IDL-0009
7	IDL-0006	18	IDL-0005	28	HDW-0579
8	HDW-0196	19	BRG-0017	29	HDW-0643
9	ELE-0147	20	BRG-0016		

10,000 RPM OPTION

	PART #		PART #		PART #
1	PLM-0034	10	IDL-0004	21	BRG-0016
2	CYL-0006	11	IDL-0000	22	HDW-0412
3	ELE-0145	12	HDW-0605	23	IDL-0010
3a	ELE-1202			24	IDL-0012
4	HDW-0612			25	HDW-0579
5	IDL-0011	16	BRG-0058	26	IDL-0008
6	IDL-0006	17	IDL-0005	27	HDW-0643
7	ELE-0147	18	BRG-0017	28	IDL-0018
8	HDW-0196	19	BRG-0016	29	HDW-0277
9	BRG-0058	20	BRG-0015		

WAYLUBE ASSEMBLY

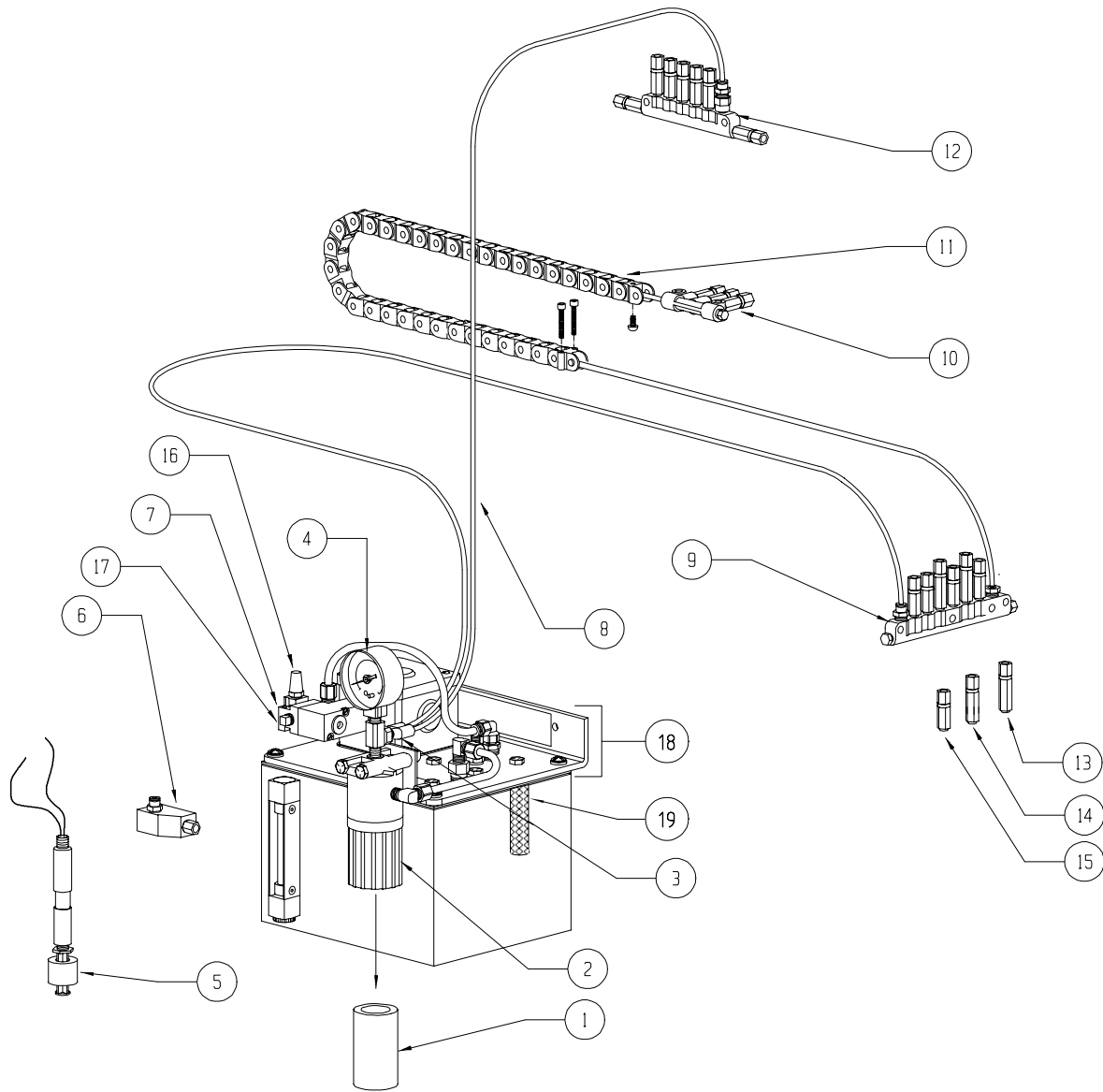

WAYLUBE PUMP ASSEMBLY

	PART #		PART #		PART #		PART #
1	LUB-0049	7	VLV-0028	13	LUB-0085	19	HDW-1039
2	LUB-0050	8	PLM-0022	14	LUB-0084		
3	PLM-0049	9	LUB-0041	15	LUB-0083		
4	REG-0018	10	LUB-0044	16	PLM-0084		
5	LUB-0036	11	CVR-0041	17	PLM-0036		
6	LUB-0051	12	LUB-0045	18	LUB-0038		

DUAL ARM TOOL CHANGER

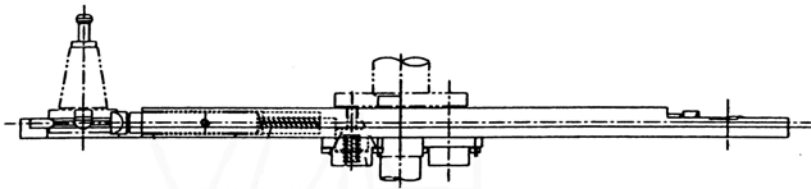
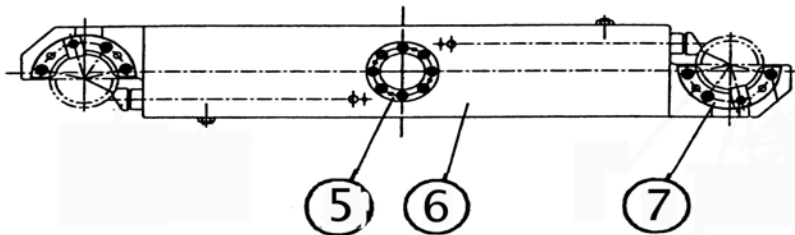
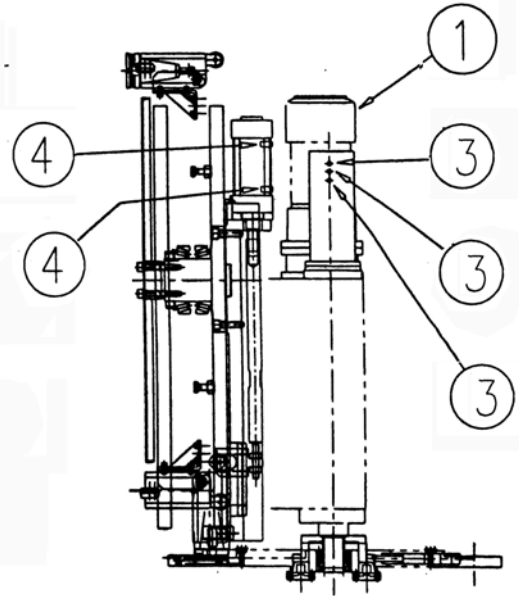
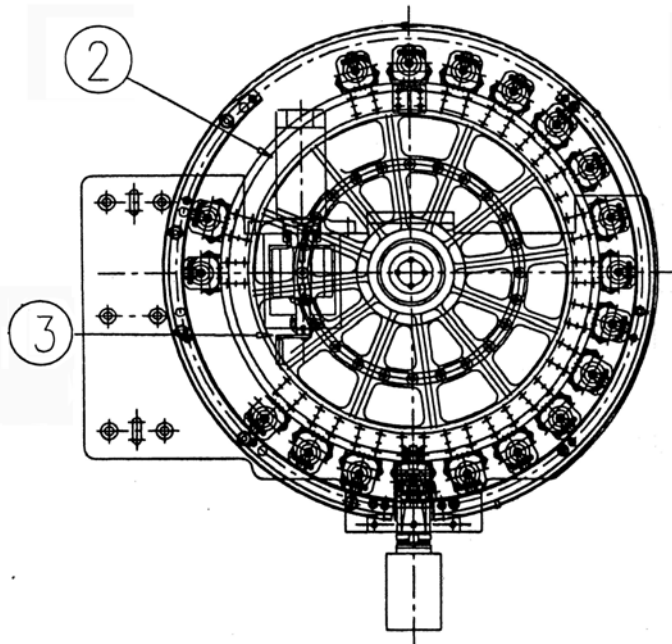

DUAL ARM TOOL CHANGER

	PART #
1	MTR-0181
2	MTR-0180
3	ELE-1185
4	ELE-1186
5	ATC-0155
6	ATC-0164
7	(BT) ATC-0163
7	(BT) ATC-0165

10K RPM SPINDLE ASSEMBLY

10,000 RPM SPINDLE ASSEMBLY

	PART #
1	HDW-0177
2	HDW-0307
3	DRB-0015
4	HDW-0180
5	DRB-0019
6	DRB-0014
7	BRG-0004
8	DRB-0016
9	HDW-0158
10	HDW-0195
11	SPN-0084
12	DRB-0004
13	BRG-0005
14	DRB-0026 ⁽¹⁾
15	BRG-0005
16	HDW-0155
17	HDW-0181
18	PLM-0034
ASSY SPN-0007 ⁽²⁾	

¹Not sold separately. Sold with assembly DRB-0003 (includes pieces 1-9, 14 & 15).

²Assembly includes all parts listed on this page plus PUL-0020.

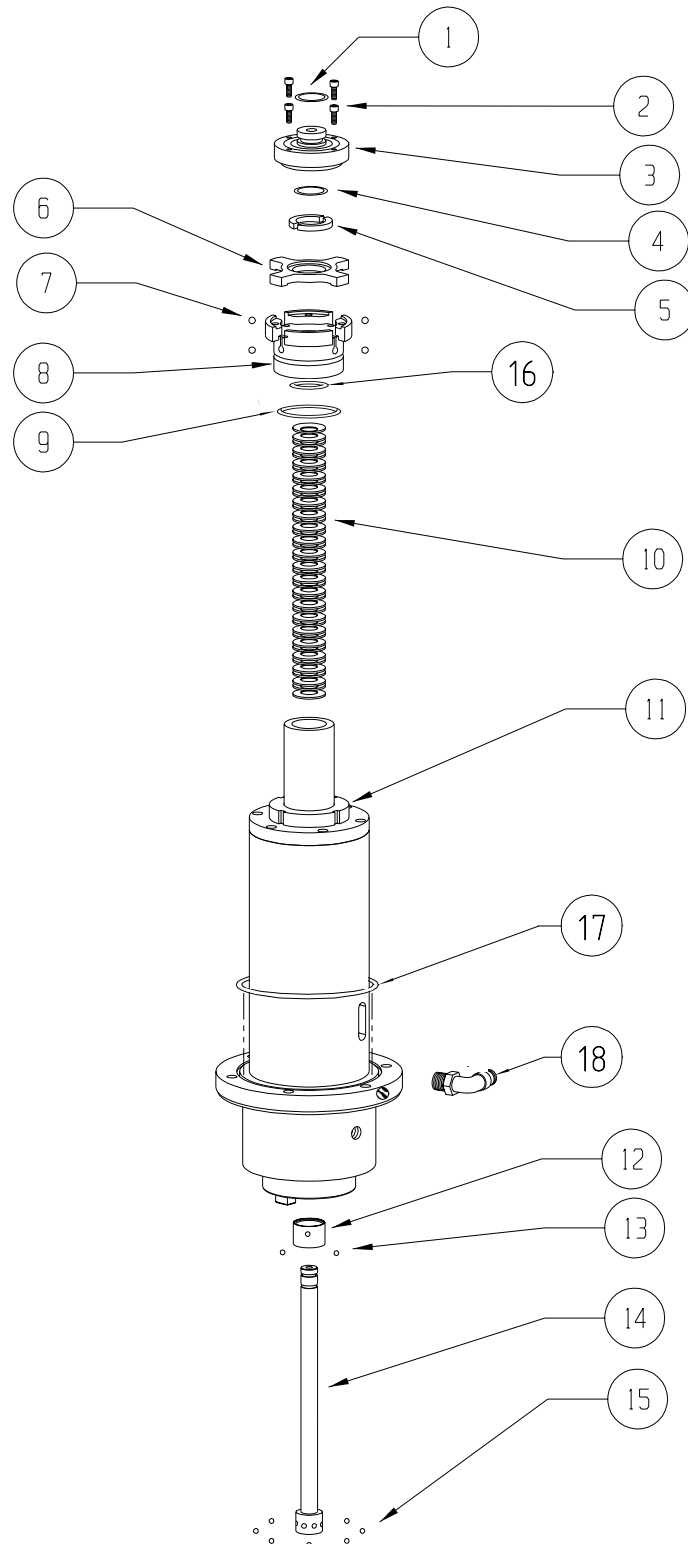

COOLANT THRU SPINDLE

CNT-0015, Coolant-thru Seal Conversion Kit
 CNT-0150, Seal Repair Kit

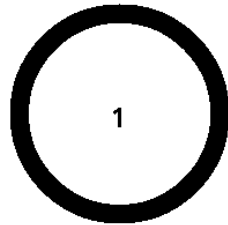

HDW-0158



HDW-0177

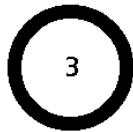

HDW-0150



HDW-0917

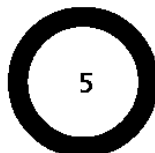

HDW-1102

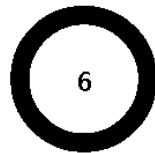

HDW-0156

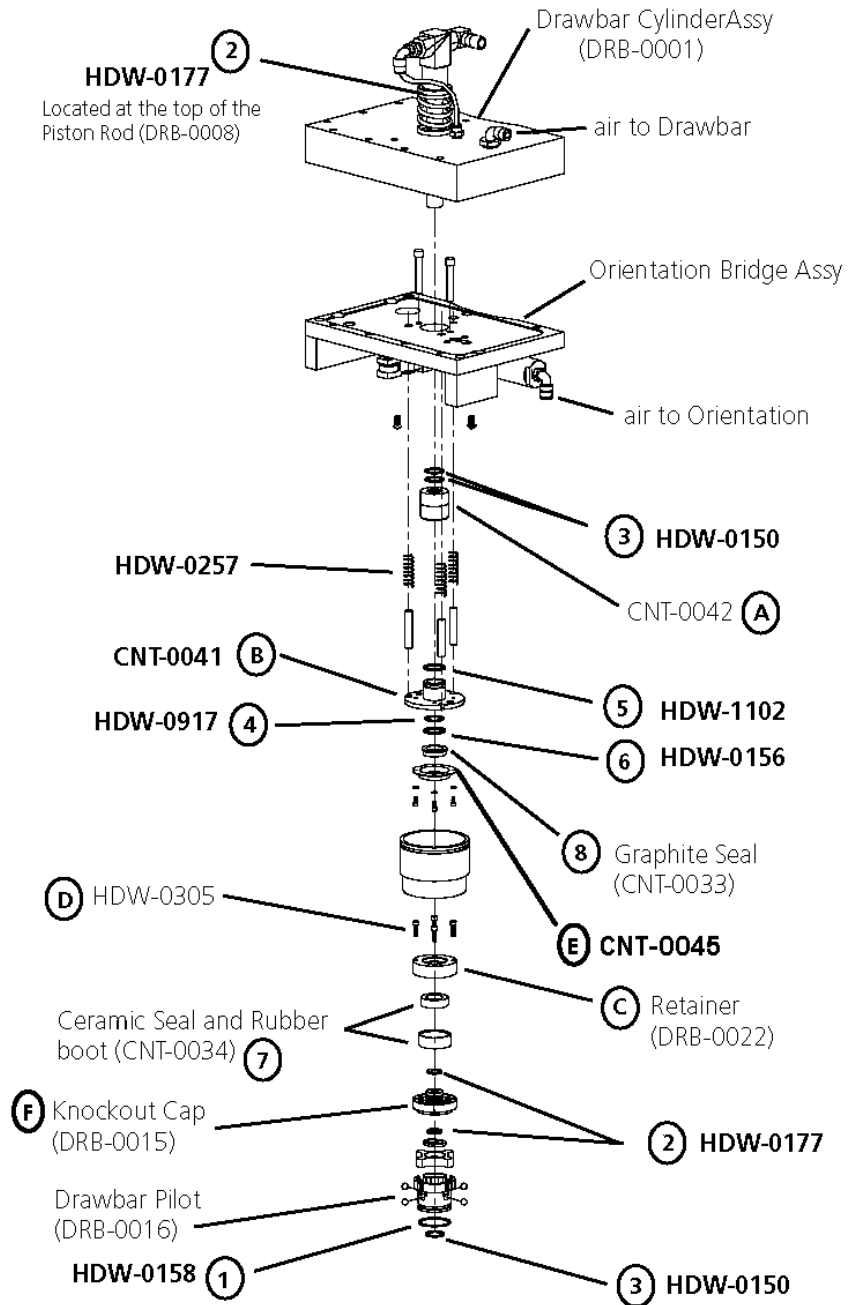

CNT-0150 O-RINGS AND SEALS ONLY (1-8)
 CNT-0015 FOR CONVERTING OLDER MODELS (1-8 AND A-F)

CNC CABINET ASSEMBLY

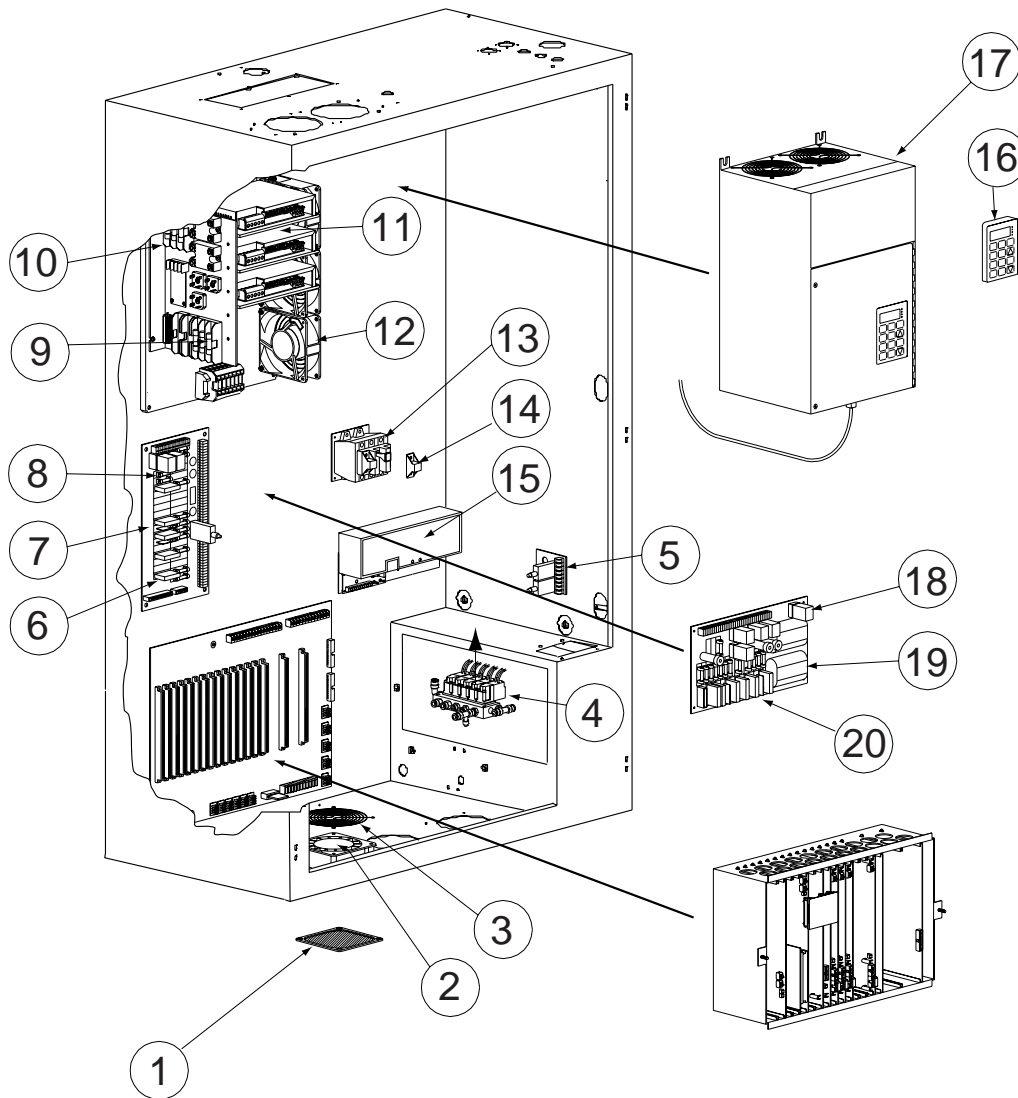

CNC CABINET ASSEMBLY

	PART #		PART #		PART #
1	HDW-0849	9	ELE-0840	17	INV-0056 (AMC)
2	ELE-0123	10	ELE-0837		INV-0041 (Baldor)
3	HDW-0850	11	AMP-0036		INV-0020 (HT)
4	VLV-0054	12	ELE-0123	18	ELE-0072
5	PCB-0046	13	ELE-0132	19	PCB-0195
6	ELE-0070	14	ELE-0138	20	ELE-0070
7	PCB-0194	15	ELE-0961		
8	ELE-0101	16	INV-0017 (Baldor)		

CARD CAGE ASSEMBLY

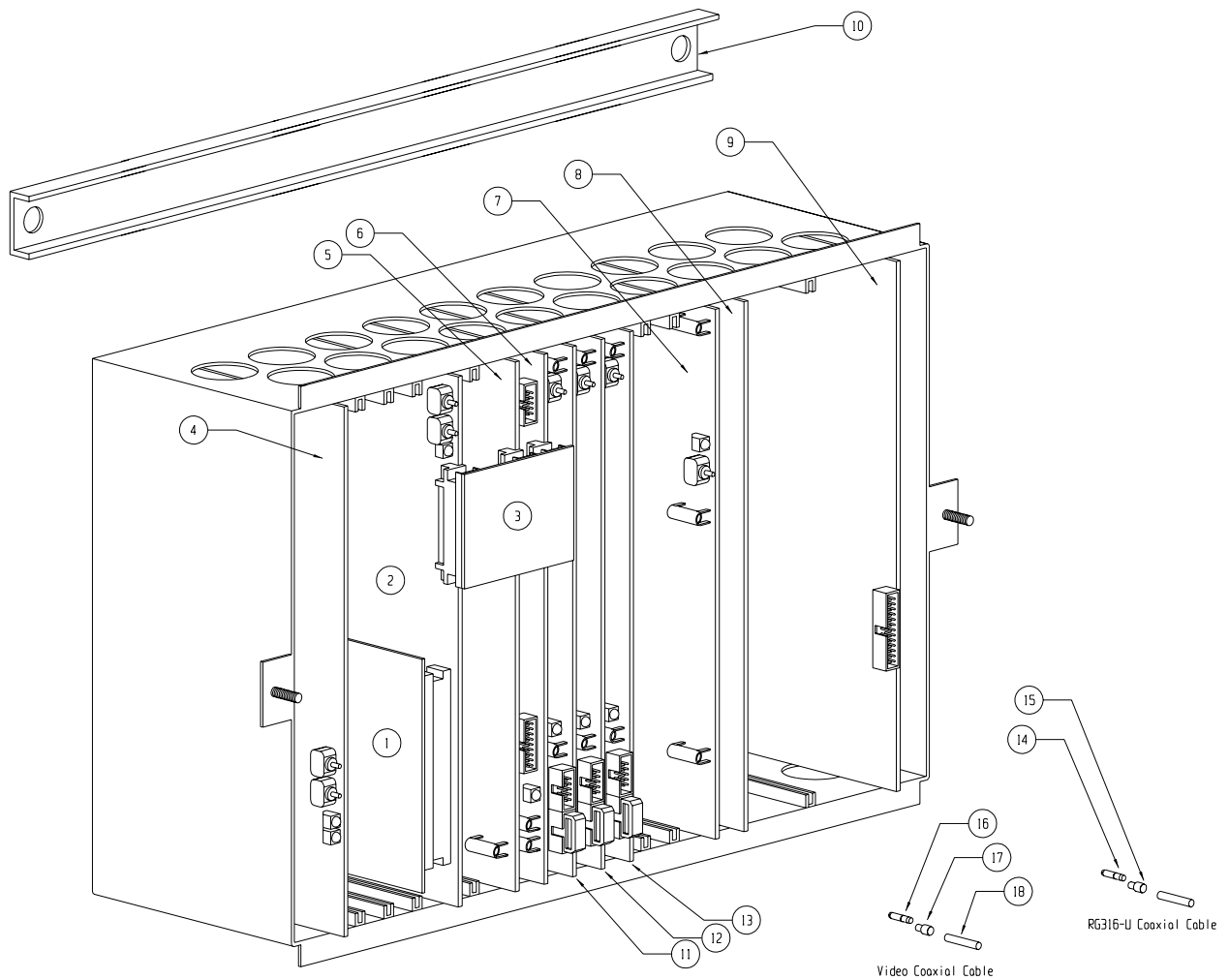

	PART #		PART #
1	PCB-0094	10	STM-0029
2	PCB-0030	11	PCB-0217
3	PCB-0189	12	PCB-0217
4	PCB-0209	13	PCB-0217
5	PCB-0032 (88HS)	14	WIR-0040
	PCB-0033 (32MP)	15	WIR-0041
6	PCB-0206	16	WIR-0038
7	PCB-0141	17	WIR-0039
8	PCB-0000	18	WIR-0086
9	PCB-0009		

SLOT	PART #	BOARD #	SLOT	PART #	BOARD #
1	PCB-0209	1550-2B	10	PCB-0217	1010-6
2			11	PCB-0217	1010-6
3			12		
4	PCB-0189	1730-5	13		
5	PCB-0030	1400-5	14	PCB-0217	1010-6
6			15	PCB-0000	1020
7	PCB-0032	1420-4	16	PCB-0008	1050-3
8	PCB-0206	1030-1	17	PCB-0005	1040
9	PCB-0217	1010-6			

JUNCTION BOX ASSEMBLY

CHILLER CABINET ASSEMBLY

	PART #		PART #
1	HDW-0849	11	ELE-0945
2	WIR-0121	12	PMP-0000
3	WIR-0117	13	PLM-0042
4	REG-0009	14	PLM-0029
5	REG-0008	15	PLM-0024
6	REG-0005	16	PLM-0042
7	ELE-0123	17	CNT-0035
8	HDW-0850	18	PLM-0210
9	ELE-0200	19	CNT-0047
10	PCB-0020		

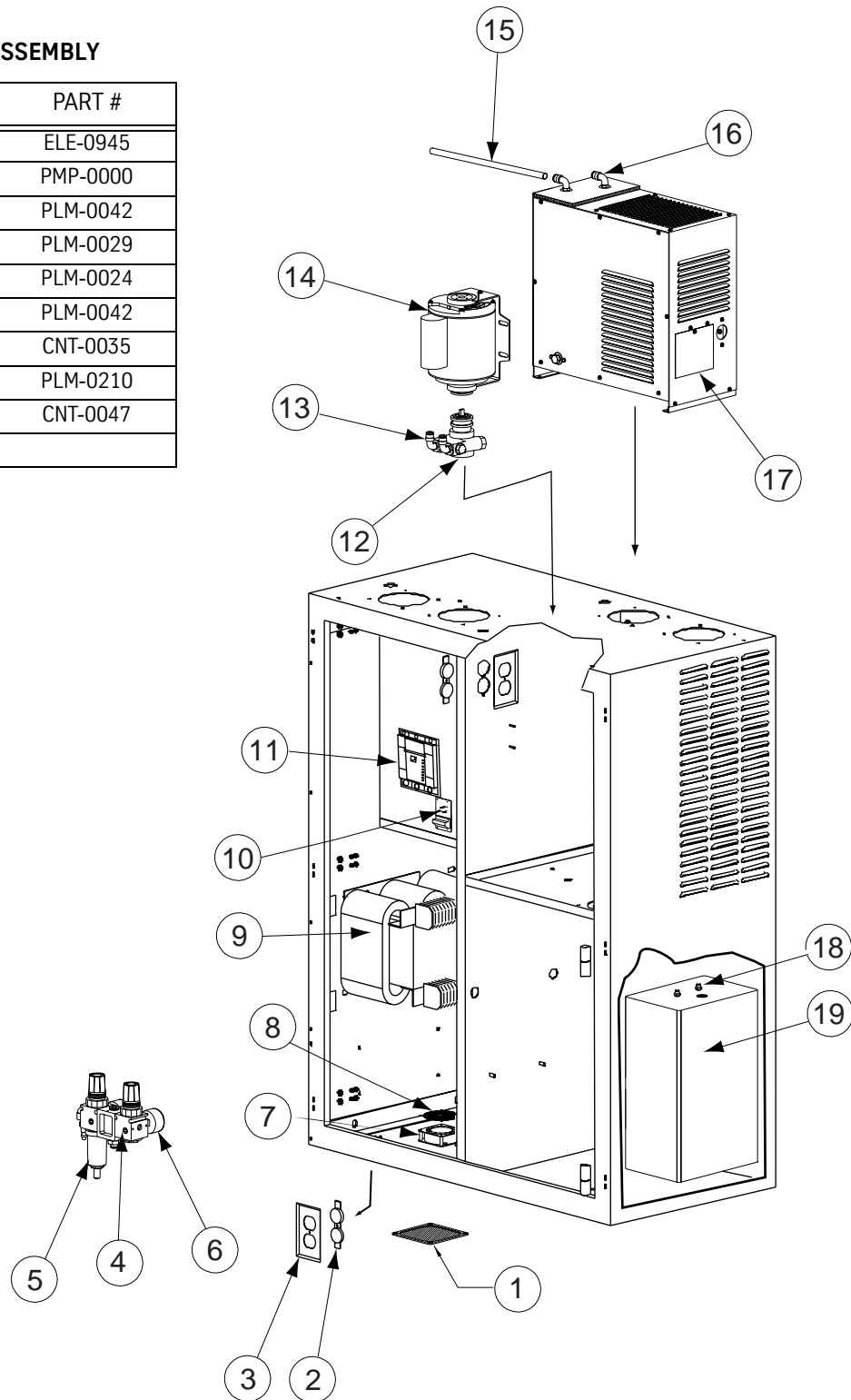

CE CNC CABINET ASSEMBLY

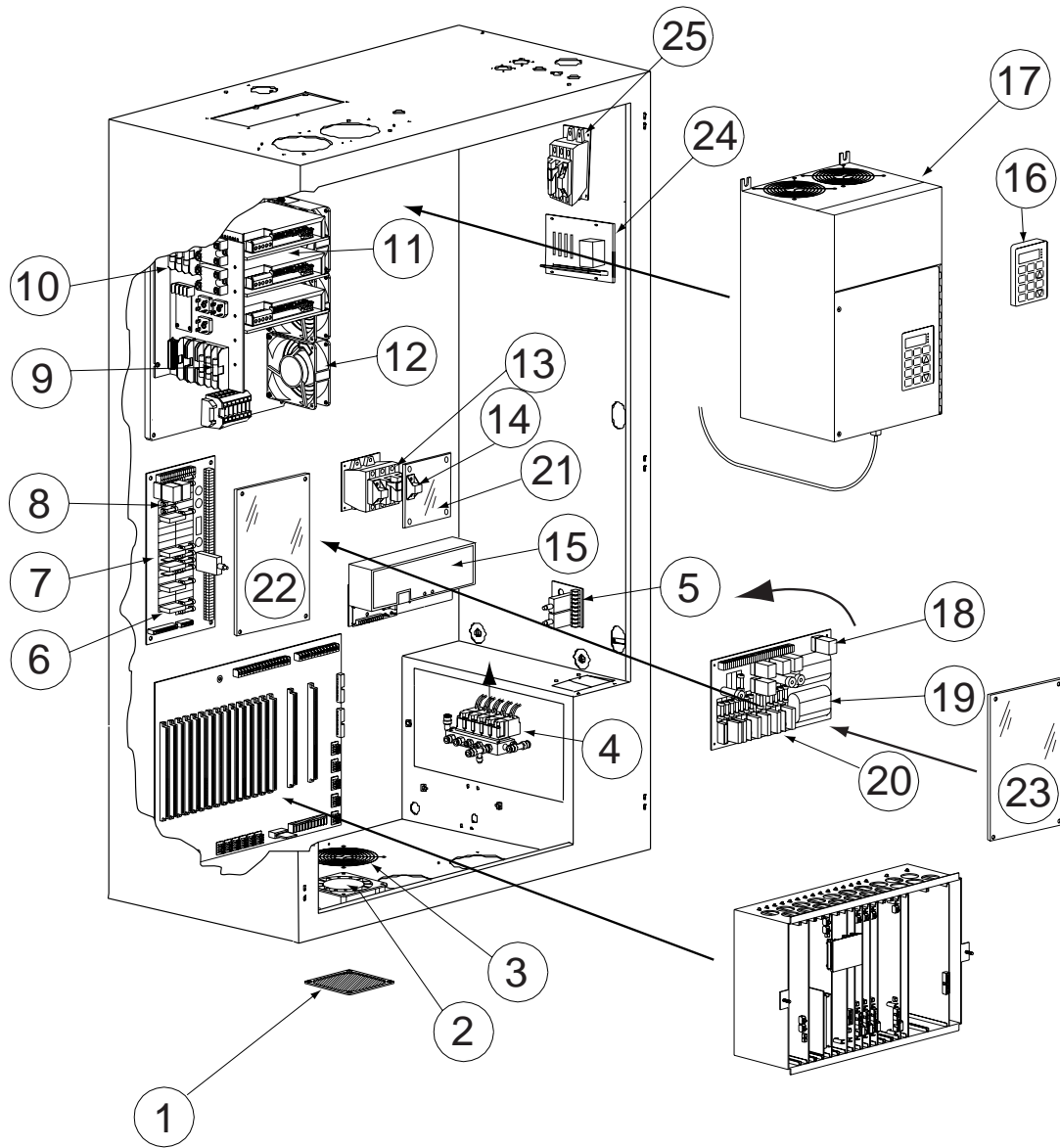

CE CNC CABINET ASSEMBLY

	PART #		PART #		PART #		PART #		PART #
1	HDW-0849	7	PCB-0194	13	ELE-0132	18	ELE-0072	24	PCB-0196
2	ELE-0123	8	ELE-0101	14	ELE-0138	19	PCB-0195	25	ELE-1025
3	HDW-0850	9	ELE-0840	15	ELE-0961	20	ELE-0070		
4	VLV-0054	10	ELE-0837	16	INV-0017 (Baldor)	21	ELE-0349		
5	PCB-0046	11	AMP-0036	17	INV-0056 (AMC)	22	ELE-0849		
6	ELE-0070	12	ELE-0123		INV-0041 (Baldor)	23	ELE-0848		

CE JUNCTION BOX ASSEMBLY

CE JUNCTION BOX ASSEMBLY

	PART#		PART#
1	HDW-0849	11	ELE-0946
2	WIR-0121	12	PMP-0000
3	WIR-0117	13	PLM-0042
4	REG-0009	14	PLM-0029
5	REG-0008	15	PLM-0024
6	REG-0005	16	PLM-0042
7	ELE-0123	17	CNT-0035
8	HDW-0850	18	PLM-0210
9	ELE-0200	19	CNT-0047
10	PCB-0020	20	ELE-0762

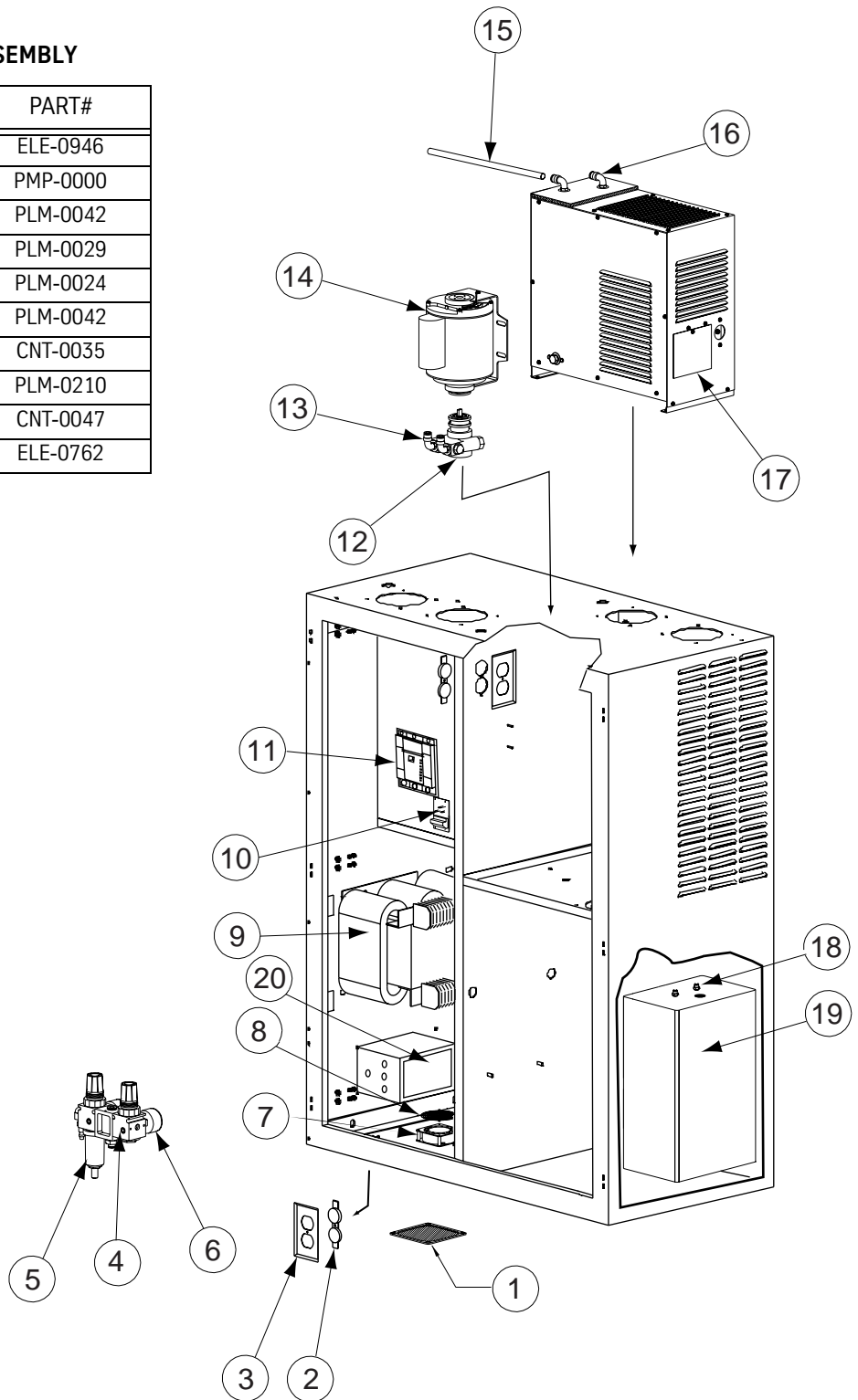

MP PENDANT ASSEMBLY

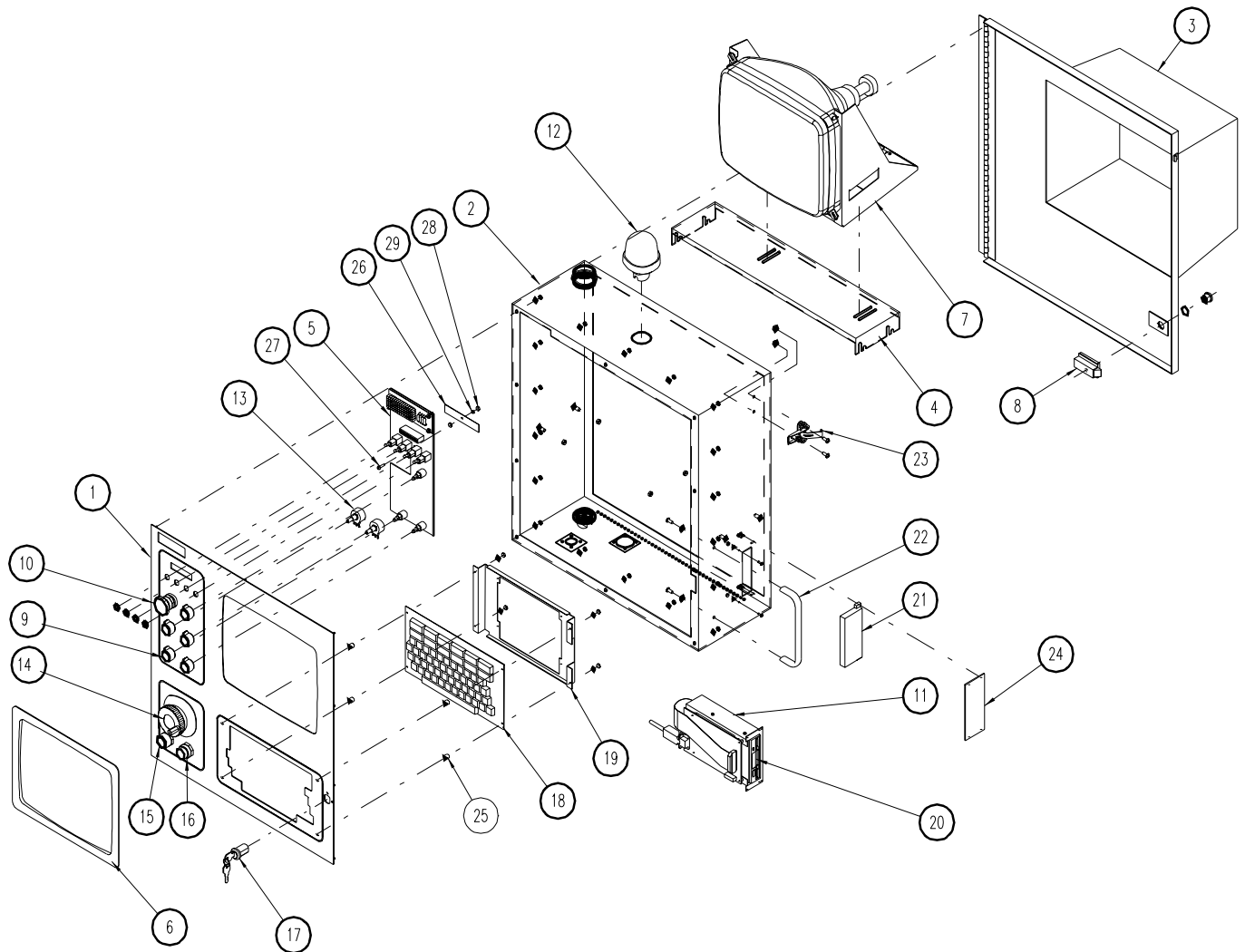

MP PENDANT ASSEMBLY

	PART #		PART #		PART #		PART #
1	CTR-0134		ELE-0888	15	ELE-0093	24	STM-0547
2	STM-0945 (2 of 4)		ELE-0889	16	ELE-0091	25	HDW-1083
3	STM-0945 (3 of 4)	8	HDW-0221	17	ELE-0096	26	ELE-1184
4	STM-0951	9	HDW-0621	18	ELE-0083	27	HDW-1082
5	PCB-0200	10	ELE-0673	19	STM-0128	28	HDW-1081
6	CTR-0118	11	STM-0470	20	ELE-0913	29	HDW-0456
	CTR-0136	12	ELE-0969	21	CTR-0014		
	CTR-0135	13	ELE-0380	22	HDW-0182		
7	ELE-1072	14	MPG-0020	23	HDW-0925		

88HS PENDANT ASSEMBLY

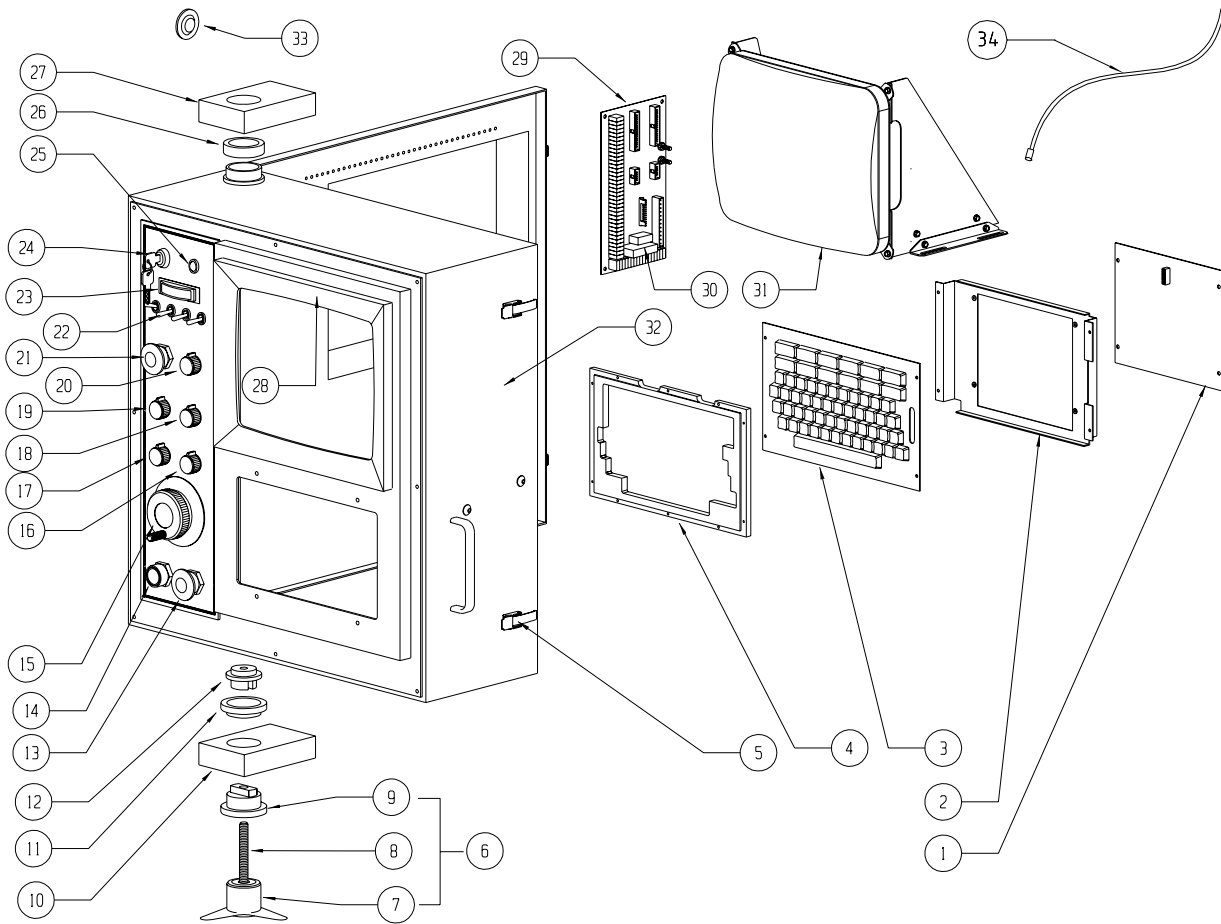

88HS PENDANT ASSEMBLY

	PART #		PART #		PART #		PART #
1	PCB-0012	10	CTR-0009	19	ELE-0067	28	HDW-0847
2	STM-0128	11	BRG-0077	20	ELE-0078	29	PCB-0019
3	ELE-0083	12	CTR-0007	21	ELE-0112	30	ELE-0070
4	CTR-0009	13	ELE-0111	22	ELE-0095	31	ELE-0189
5	HDW-0216	14	ELE-0110	23	ELE-0108	32	CTR-0021
6	CTR-0022	15	MPG-0007	24	ELE-0096	33	HDW-0185
7	HDW-0675		MPG-0018	25	ELE-0090	34	WIR-0086
8	CTR-0018	16	ELE-0078	26	HDW-0724		
9	CTR-0008	17	ELE-0081	27	CTR-0006		
		18	ELE-0068				

COOLANT TANK ASSEMBLY

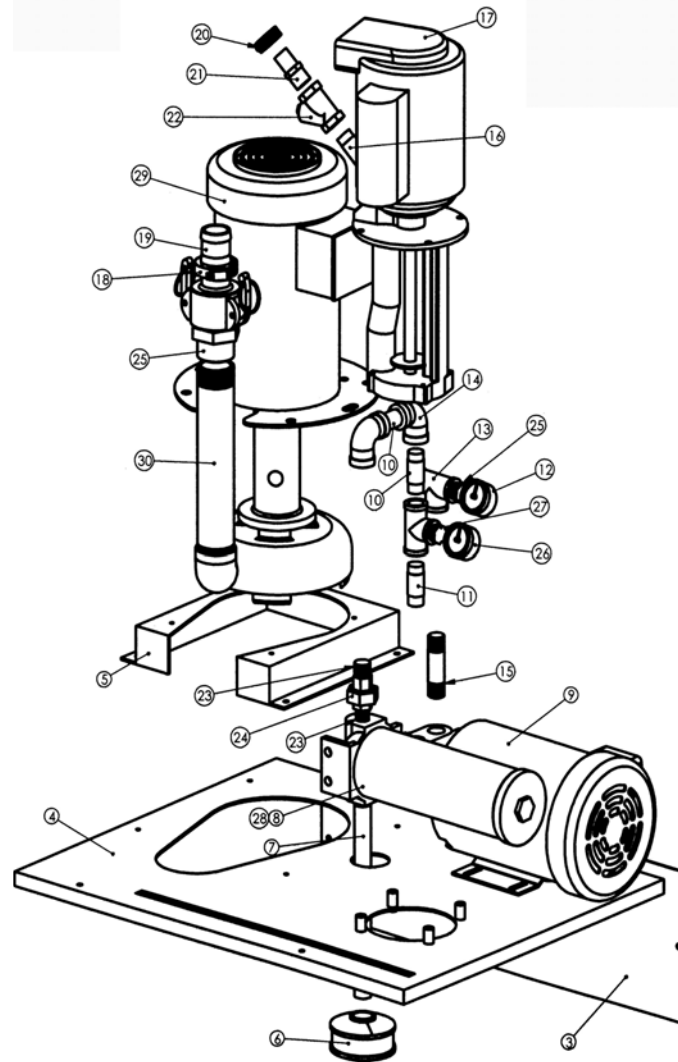

COOLANT TANK ASSEMBLY

	PART #		PART #		PART #		PART #
1		9	PMP-0008	17	PMP-0017	25	PLM-0217
2		10	PLM-0060	18	HDW-0764	26	PLM-0216
3		11	PLM-0094	19	PLM-0021	27	REG-0034
4		12	REG-0018	20	HDW-0252	28	CNT-0029
5	STM-1023	13	PLM-0089	21	PLM-0076	29	PMP-0010
6	CNT-0025	14	PLM-0067	22	VLV-0018	30	PLM-0065
7	PLM-0233	15	PLM-0214	23	PLM-0091		
8	CNT-0027	16	PLM-0007	24	PLM-0212		

COOLANT TANK ASSEMBLY

This page intentionally left blank.

SHEETMETAL ASSEMBLY

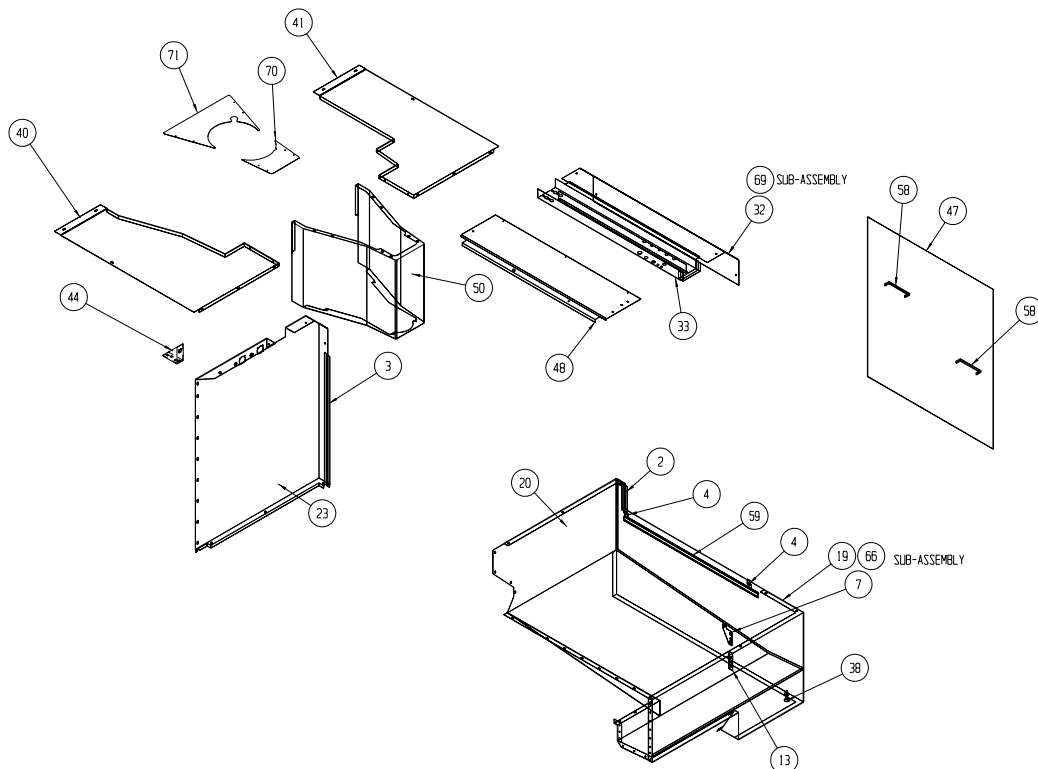
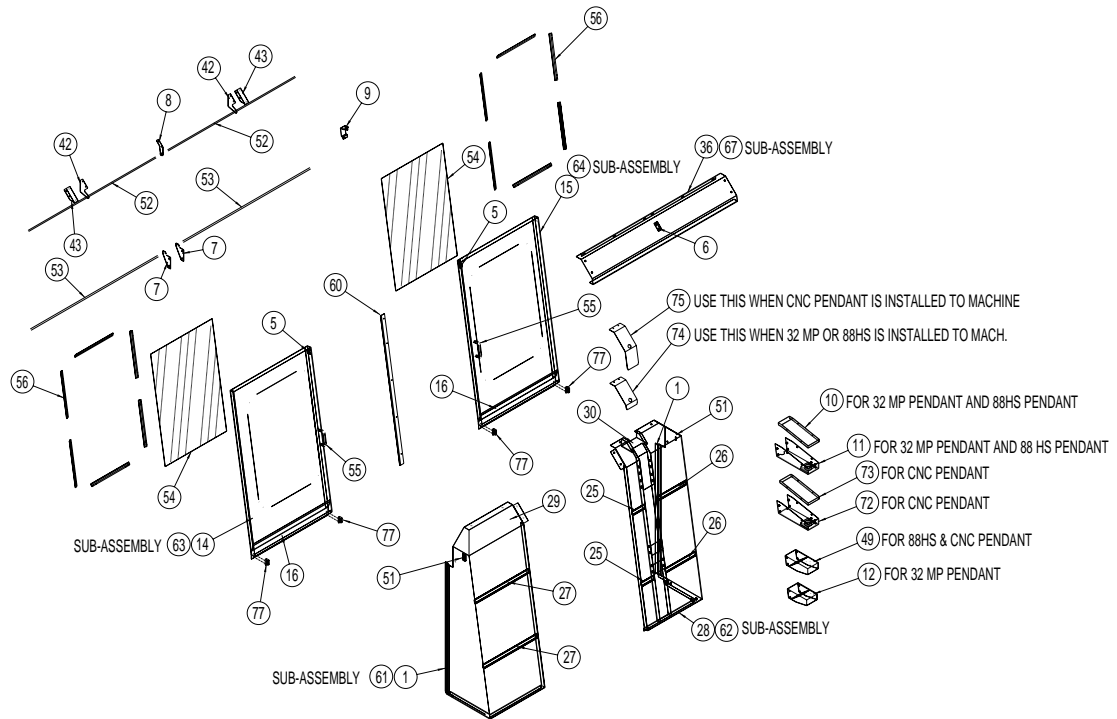

SHEETMETAL ASSEMBLY

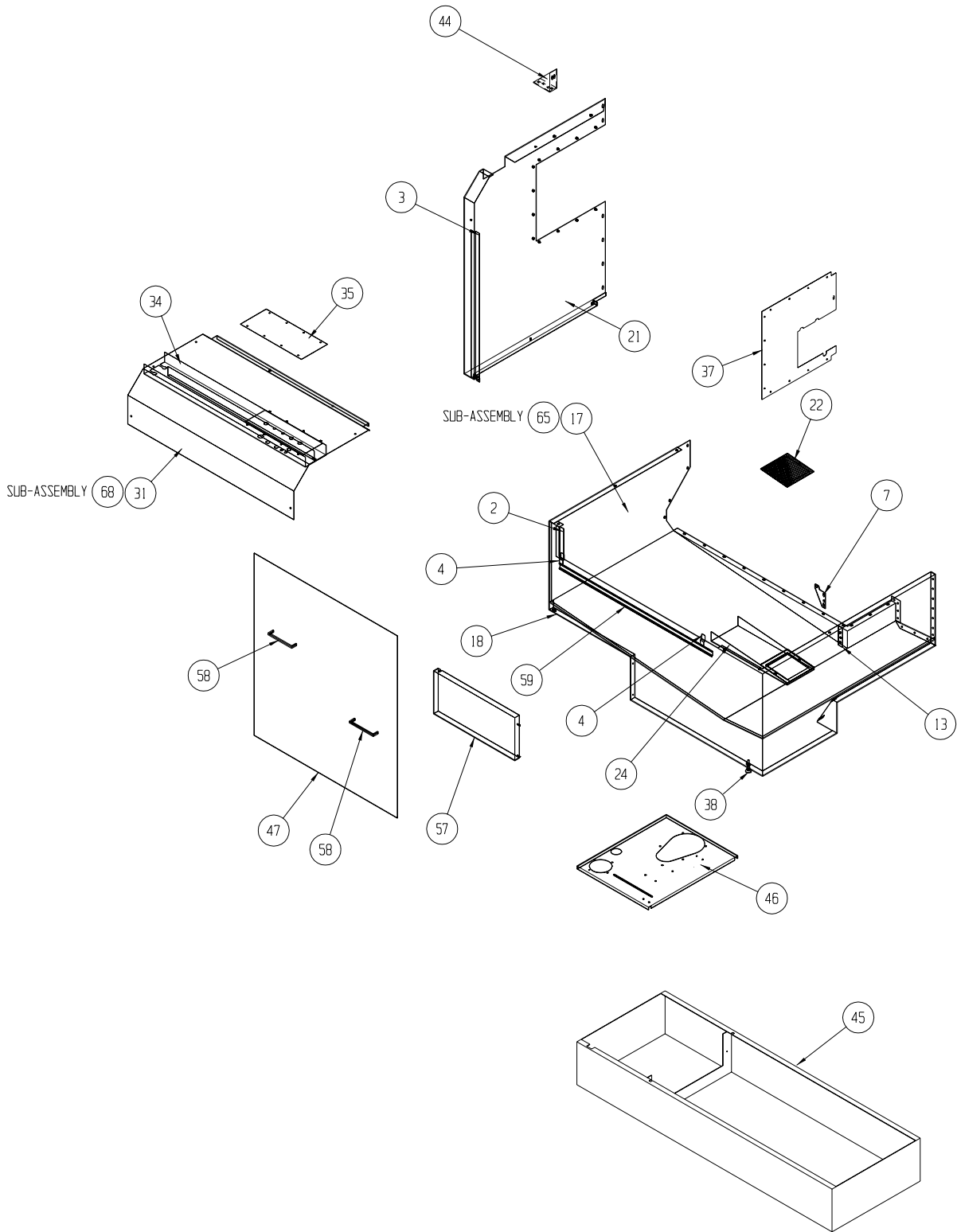

SHEETMETAL ASSEMBLY

SHEETMETAL ASSEMBLY

	PART #		PART #		PART #		PART #
1	STM-0727	21	STM-0839	42	STM-0741	62	STM-0838
2	STM-0727	22	STM-0746	43	STM-0742	63	STM-0736
3	STM-0727	23	STM-0840	44	STM-0887	64	STM-0737
4	STM-0727	24	STM-0727	45	STM-0815	65	STM-0835
5	STM-0736	25	STM-0842	46	ASY-0025	66	STM-0836
6	STM-0847	26	STM-0842	47	STM-0243	67	STM-0847
7	STM-0740	27	STM-0842	48	STM-0912	68	STM-0843
8	STM-0743	28	STM-0838	49	STM-0885	69	STM-0841
9	STM-0738	29	STM-0842	50	STM-0888	70	STM-0904
10	STM-0749	30	STM-0838	51	STM-0739	71	STM-0903
11	STM-0750	31	STM-0843	52	DOR-0659	72	STM-0913
12	STM-0748	32	STM-0841	53	DOR-0067	73	STM-0914
13	STM-0835	33	STM-0841	54	DOR-0007	74	STM-0915
14	STM-0736	34	STM-0843	55		75	STM-0916
15	STM-0737	35	STM-0881	56	STM-0084	76	
16	STM-0736	36	STM-0847	57	STM-0892	77	DOR-0016
17	STM-0835	37	STM-0852	58	HDW-0182	78	STM-0879
18	STM-0835	39	STM-0846	59	STM-0842	79	
19	STM-0836	40	STM-0846	60	STM-0893	80	
20	STM-0836	41	STM-0849	61	STM-0842	81	