

Safety Section



This safety section covers information for: VMCs EMC, 5, 10, 15, 15XT, 2016L, 2216, 3016, 3016L, 3020, 4020, 4020A, 4525, 5020A, 6030, 6535 and 8030; Rotary Tables VH65, TR65, and V300 (400) MM; and VH5C Indexer.

Fadal

TABLE OF CONTENTS

TABLE OF CONTENTS..... 1

MODIFICATIONS, ALTERATIONS, AND CHANGES..... 3

SAFETY WARNINGS 4

GENERAL..... 7

WARNINGS AND CAUTIONS 8

PICTORIALS 8

POTENTIAL HAZARDS TO PERSONNEL..... 8

PHYSICAL ENVIRONMENT AND OPERATING CONDITIONS (CE SPECIFICATIONS)..... 8

ELECTRIC SHOCK 9

SHARP EDGES ON CUTTING TOOLS 9

ROTATING CUTTING TOOLS 9

NOISE 10

NOISE (CE COMPLIANCE)..... 10

COMPRESSED AIR (CE COMPLIANCE)..... 11

ADDITIONAL SAFETY PRECAUTIONS..... 12

SAFETY LABELS 14

LBL-0123 14

LBL-0129 15

LBL-0158 15

LBL-0127 15

LBL-0130 16

LBL-0163 16

LBL-0126 17

LBL-0128 18

LBL-0125 19

LBL-0235 20

LBL-0131 21

LBL-0263 21

LBL-0187 22

LBL-0234 22

LBL-0124 23

LBL-0040 24

LBL-0036 24

SAFETY LABEL LOCATIONS..... 25

4020S..... 25

5020A, 4020A, 4020, 3016L, 2216, 2016L, 15, 15XT 27

6030, 8030..... 29

4525, 3020..... 33

CE SAFETY LABELS.....	37
LBL-0431 small (CE) LBL-0434 large (CE)	37
LBL-0432 (CE)	37
LBL-0132 (CE)	38
LBL-0435 (CE)	38
LBL-0460 (CE)	39
LBL-0430 (CE)	39
LBL-0436 (CE)	40
LBL-0433 (CE)	40
LBL-0443 (CE)	41
PROHIBITIONS	42
LBL-0441 (CE)	42
REQUIRED ACTIONS	43
LBL-0439 (CE)	43
LBL-0440 (CE)	43
LBL-0442 (CE)	44
LBL-0438 small (CE) LBL-0437 large (CE)	44
CE SAFETY LABEL LIST AND LOCATION	45

Corporate Office voice (818) 407-1400fax (818) 407-0020
Service / Parts voice (818) 727-2100fax (818) 407-1004
Programming Support voice (818) 727-2100fax (818) 407-0061

support@fadal.com
20701 Plummer Street Chatsworth California 91311 U.S.A.

The information in this document is reviewed regularly and any necessary changes will be incorporated in the next revision. We welcome any suggestions for improvement.

Material is subject to change without notice.

This manual is for the exclusive use of Fadal Customers and Distributors. The reproduction, transmission or use of this document or its contents is not permitted without the expressed written permission of Fadal Machining Centers.

© Copyright 2001 Fadal Machining Centers.



MODIFICATIONS, ALTERATIONS, AND CHANGES

Do not modify or alter this equipment without the written approval of Fadal Machining Centers. Unauthorized changes may lead to hazardous conditions. Address any questions to Fadal's Service Department.

SAFETY WARNINGS

1. **WARNING! WEAR ANSI or CE APPROVED SAFETY GLASSES AT ALL TIMES.** Everyday glasses are not designed for protection. Only ANSI or CE approved safety glasses have impact resistant lenses. Hearing protection must be worn when operations exceed 90 (85 CE) decibels.
2. **KEEP DOORS CLOSED WHILE MACHINING.**
3. **WEAR PROPER APPAREL.** Do not wear loose clothing, gloves, neckties, rings, bracelets, or other jewelry that might get caught in moving parts or areas of potential electric shock. Non-slip footwear is recommended.
4. **CONTAIN LONG HAIR.** Tie long hair back and wear protective hair covering to contain long hair.
5. **USE A NIOSH OR CE APPROVED DUST MASK OR RESPIRATOR.** Protection is recommended when cutting operations are dusty, or exceed the permissible exposure limit.
6. **KEEP WORK AREA CLEAN.** Good housekeeping practices encourage safety.
7. Read **SPINDLE, MANUALLY LOADING & UNLOADING A HOLDER** in the Operator's Manual.
8. **DO NOT OPERATE THE MACHINE UNDER THE INFLUENCE OF DRUGS OR ALCOHOL, PRESCRIBED OR OTHERWISE.**
9. **READ THE SAFETY WARNINGS SUPPLIED WITH ALL TOOLING.**
10. **MAINTAIN TOOLS WITH CARE.** Keep tools sharp and clean for best performance and to reduce the risk of injury. Follow instructions for lubrication and for changing accessories.
11. **REMOVE ADJUSTING KEYS AND WRENCHES.** Always check that keys and wrenches are removed from tools and tooling before starting the machine.
12. **DO NOT EXCEED THE MANUFACTURER'S RECOMMENDED MAXIMUM RPM FOR THE TOOL.** When tools are placed in the spindle, verify the current RPM commanded in the control before starting the spindle.
13. **SECURE TOOLS PROPERLY IN THEIR HOLDERS.**
14. **SECURE WORK.** Use common machining practices for holding (fixturing) material to be machined.
15. **REMOVE ALL TOOLS FROM THE SPINDLE AND TOOL CHANGER** before servicing and changing accessories such as tooling, fixtures, indexers, the tail stock of a fourth axis and any fourth axis or fourth-fifth axis combination, etc.
16. **ALWAYS DEBUG A NEW PROGRAM** before running it in the AUTO mode. (See **DEBUG PROGRAM** in the User's Manual.)
17. The machine tool **MUST** be connected to a grounded, metal, permanent wiring system, or to a system having an equipment-grounding conductor.

18. **DO NOT OPERATE THE MACHINE IN AN UNSAFE ENVIRONMENT.** Do not use the machine in damp or wet locations, or expose to rain. Keep the work area well lighted.
19. **DO NOT FORCE TOOL.** Tools are designed to perform properly and safely at proper rates. Keep tools sharp.
20. **USE THE CORRECT TOOL.** Do not attempt to use tools or attachments to perform a job for which they were not designed.
21. **DON'T OVERREACH.** Keep proper footing and balance at all times. Use a steady object for support when reaching over the machine.
22. **REDUCE THE RISK OF UNINTENTIONAL STARTING.** Power off the machine at the main disconnect switch and use the proper lockout/tagout procedures while working within the chip enclosure, or when there is potential for a release of energy.
23. **POWER OFF THE MACHINE AT THE MAIN DISCONNECT SWITCH AND LOCK OUT WHEN WORKING INSIDE ANY OF THE ELECTRONIC CABINETS.**
24. **USE RECOMMENDED ACCESSORIES.** Refer to the User's Manual for FADAL recommended accessories. Unapproved accessories increase the risk of injury.
25. **NEVER STAND ON OR IN THE MACHINE.** Besides the risk of slipping or falling, serious injury could occur if a tool is unintentionally contacted.
26. **CHECK FOR DAMAGED PARTS.** Always check all parts for binding, breakage, and any other condition that will affect the proper operation of the machine and/or increase the risk of injury. Damaged or missing parts must be repaired or replaced BEFORE operating the machine.
27. **NEVER LEAVE THE MACHINE UNATTENDED.** Turn the power off to the machine when leaving the machine unattended. Never leave the machine until it comes to a complete stop.
28. **DO NOT DISCONNECT THE FRONT DOOR SAFETY SWITCHES.**
29. **WIPE UP SPILLS.** Immediately cover with absorbent material and wipe up coolant and oil spills around the machine. Correct the cause of the leakage to prevent any hazards.
30. **ELECTRICAL INSTALLATION OF THE MACHINE MUST BE DONE BY A QUALIFIED ELECTRICIAN.**
31. **ONLY FADAL OR FADAL DISTRIBUTOR FACTORY AUTHORIZED INDIVIDUALS MAY INSTALL THE MACHINE.**
32. **USE PROPER SAFETY GLOVES WHEN HANDLING SHARP OR JAGGED EDGES.** Do not wear gloves around rotating machinery.

33. DO NOT USE AIR HOSES TO BLOW CHIPS OFF YOUR BODY OR CLOTHES. Serious injury to your eyes, hearing, and skin could result. Do not blow towards others.

GENERAL

A carelessly or improperly operated VMC can cause serious injury or death as well as damage or destruction of equipment. The emergency and safety procedures in this manual are to help users operate the VMC in a safe manner. The warnings in this manual follow accepted industry safety practices. Tasks involving toxic materials must be reviewed and approved by an industrial hygienist or safety engineer.

Fadal has no control over the applications the operator may use the VMC for and is not responsible for injuries or equipment damage. Read and understand the *User's Manual*. The safe use and disposal of all hazardous materials processed or used by the VMC is the responsibility of the user. All safety warnings and procedures must be followed.

It is the sole responsibility of the user to comply with all local, state, national (Federal), and international and environmental safety laws and regulations applicable to the VMC and its use.

WARNINGS AND CAUTIONS

This manual contains information that will assist qualified operators and maintenance personnel. Unqualified operators should never attempt to operate or perform maintenance on the VMC.

PICTORIALS

Pictorials are used within warnings to rapidly communicate a hazard to the reader. The pictorials and their meaning are given in this section. A diagram of the locations and types of warnings that are physically attached to, or engraved on, the VMC is also included.

POTENTIAL HAZARDS TO PERSONNEL

The most serious potential hazards associated with the VMC are:

- electric shock
- sharp edges on cutting tools
- rotating cutting tools
- noise
- compressed air

PHYSICAL ENVIRONMENT AND OPERATING CONDITIONS (CE SPECIFICATIONS)

FADAL VMCs meet or exceed the environmental requirements stated in EN 60204-1:1992 section 4.4.

Electromagnetic Compatibility meets or exceeds the levels specified by EN 50081-2:1993 and EN 50082-2:1995.

Ambient air temperature conforms as specified in EN60204-1:1992 section 4.4.2 (+5 deg C to +40 deg C).

Humidity conforms as specified in EN60204-1:1992 section 4.4.3 (relative humidity 30% to 95% non-condensing).

Altitude conforms as specified in EN60204-1:1992 section 4.4.4 (maximum altitude without derating exceeds 1000 meters above sea level).

Contaminants conform as specified in EN60204-1:1992 section 4.4.5.

Equipment is not intended for use in a corrosive atmosphere. Equipment that will be used in an environment with excessive amounts of fine conductive particulate matter (e.g. graphite) must be ordered with the graphite restraint package.

ELECTRIC SHOCK

The VMC has numerous subsystems powered by high voltage electricity. This electricity is not a hazard during most operations, however certain maintenance operations conducted by qualified individuals may require the defeat of interlocks so that power may be maintained during diagnostics or adjustments tasks. Under no circumstances should the operator defeat any interlock.

Read all applicable manuals and follow their warnings to prevent accidental electric shock. Operators must never remove shields or panels, nor should operators bypass or otherwise disable interlocks.

SHARP EDGES ON CUTTING TOOLS

Cutting tools have sharp edges that could lead to a serious cut. The tools used on the VMC are stored in a tool tray when not being used. Under most circumstances they pose no threat to operator or maintenance personnel. It is possible for personnel to come into contact with stationary cutting tools during job setup or when replacing cutting tools for any reason. Extreme care must be taken to avoid coming into contact with the sharp edges on cutting tools.

ROTATING CUTTING TOOLS

Rotating cutting tools used by the VMC create potential hazards of entanglement. A cutting hazard is also possible if the operator comes into contact with rotating cutting tools. The Polycarbonate shield is equipped with an interlock to prevent the VMC from operating when the shield is opened. Under no circumstances should operators disable or remove the interlocks.

If the interlock is not functioning properly, qualified maintenance personnel should be notified and the VMC must not be used until it is functioning properly.

Prior to starting any job, the operator on the VMC should inspect all of the cutting tools being used to ensure they are in good condition and free of defects such as cracks. The operator should also insure that only the appropriate cutting tools for the material being machined are present.

Using the wrong tool or using a damaged tool could result in the failure of the tool or material being machined. Failure of either could lead to pieces of either the tool or the material being ejected at extremely high speed. Ejection of either could lead to serious injury or death to personnel in the vicinity. Major equipment damage could also be sustained.

NOISE

Exposure to occupational hazardous noise or prolonged exposure to noise above 90 decibels may cause permanent hearing damage. The amount of noise the VMC produces varies by the type of material, speed of the cut, and several other factors.

To prevent loss of hearing from the noise of an operating VMC, hearing protection must always be worn by personnel exposed to noise above 90 decibels or above. The level of protection required may vary because of variation in the amount of noise being produced by the VMC. To insure adequate hearing protection is attained, compliance with OSHA standards is required. Consult a qualified industrial hygienist or safety engineer to insure adequate protection prior to operating the VMC.

NOISE (CE COMPLIANCE)

Exposure to occupational hazardous noise or prolonged exposure to noise above 85 decibels may cause permanent hearing damage. The amount of noise the VMC produces varies by the type of material, speed of the cut, and several other factors.

To prevent loss of hearing from the noise of an operating VMC, hearing protection must always be worn by personnel exposed to noise above 85 decibels or above. The level of protection required may vary because of variation in the amount of noise being produced by the VMC. To insure adequate hearing protection is attained, compliance with CE standards is required. Consult a qualified industrial hygienist or safety engineer to insure adequate protection prior to operating the VMC.

Continuous equivalent A-weighted sound pressure at workstation is 77dB(A) or less when tested according to Annex D of prEN 12417.

The figures quoted are emission levels and are not necessarily safe working levels. While there is a correlation between the emission and exposure levels, this cannot be used reliably to determine whether or not further precautions are required. Factors that influence the actual level of exposure of the workforce include characteristics of the work room, the other sources of noise, etc. i.e., the number of machines and other adjacent processes. Also the permissible exposure level can vary from country to country. This information, however, will enable the user of the machine to make a better evaluation of the hazard and risk.

COMPRESSED AIR (CE COMPLIANCE)

Compressed air poses a potential hazard from flying debris. Under normal conditions the compressed air may not present a hazard to the operator. Failure of any component of a compressed air system may cause parts to be ejected at high speed. Operators and maintenance personnel must always wear eye protection that meets OSHA standards and ANSI standard Z87.1 (or CE standards) when working on systems that use compressed air.

The operator may also use their shop's compressed air to remove debris from material being machined. If shop air is used for this purpose, it must be done in accordance with OSHA or CE standards. Alternative means of debris removal, such as debris rakes, should be considered. **UNDER NO CIRCUMSTANCES SHOULD THE OPERATOR ATTEMPT TO REMOVE DEBRIS WHILE THE VMC IS RUNNING.** Consult a qualified industrial hygienist or safety engineer to insure debris removal is accomplished in a safe manner and in a manner that complies with local, state, national (Federal), and international regulations.

ADDITIONAL SAFETY PRECAUTIONS

Compliance with the following safety practices is required to safely operate the VMC:

1. Never work alone on live electrical circuits. Another person qualified to turn off power to the VMC must be present when voltage is 600 or over. That person must also know CPR (cardiopulmonary resuscitation) and company emergency procedures.
2. Never wear jewelry or loose fitting clothing while working on the VMC. Long hair should be secured and under a cap.
3. .Wear eye protection when operating or maintaining this machine.
4. Never operate this machine without all guards, safety shields, and interlocks in place and functioning properly.
5. Report any unsafe conditions to the supervisor immediately. Do not operate this machine until the unsafe condition has been resolved. If the operator is not familiar with a condition, consult an industrial hygienist or safety engineer for approval prior to proceeding.
6. Comply with all local, state, national (Federal), and international (CE) regulations pertaining to the handling, processing or disposal of hazardous materials used in conjunction with VMC operations.
7. Do not leave electrical cords where they may be tripped over. Secure all electrical cords and compressed air lines connected to the VMC.
8. Keep a UL or CE approved fire extinguisher close to the VMC and make sure all personnel know the location of the fire extinguisher.
9. Do not turn the VMC on or try to operate it if there are explosive or flammable gases present.
10. Do not install substitute parts or modify the VMC without consulting a safety engineer. Contact FADAL or your local distributor for authorized repair parts and service.
11. The Polycarbonate viewing panels are an integral part of the safety enclosure for the VMC. They must be inspected at least monthly for any signs of reduced effectiveness (such as cracking or crazing) and replaced immediately if such signs or other indications of reduced effectiveness are noticed. Furthermore, tests have indicated that coolants can reduce the effectiveness of the panels over a period of time, therefore the panels should be replaced, regardless of condition, at least every two years.

12. The Polycarbonate shield is equipped with an interlock to prevent the VMC from operating when the shield is opened. Under no circumstances should the operator disable or remove the interlocks. If power is lost to the VMC, the spindle will free wheel for 30 seconds. Under no circumstances should the operator open the Polycarbonate shield before the spindle stops rotating completely.
13. The machine is not intended for use with flammable or harmful substances.
14. Take appropriate additional safety precautions and measures when working with magnesium, wood, or other combustible materials.
15. Dust removal equipment is needed when working with dust-producing materials or procedures.
16. Due to danger of slips or falls on a wet or oily surface, table and enclosure floor should be clean and dry before using them for maintenance access.
17. Do not enter enclosure area unless machine is off and power is locked out.





SAFETY LABELS

LBL-0123

SAFETY INSTRUCTIONS

DANGER

All milling machines contain hazards from rotating cutting tools, belts and pulleys, high voltage electricity, noise, and compressed air.

				
---	---	--	---	---

- Rotating cutting tools can severely injure you. NEVER place any part of your body near rotating cutting tools. Inspect cutting tools for damage before operating this machine. DO NOT operate this machine unless doors are closed. DO NOT operate this machine unless door interlocks are working properly.
- Rotating pulleys and belts can severely injure you. NEVER place any part of your body near rotating or moving parts. ALWAYS ensure guards are in place before operating this machine.
- High voltage electricity can severely injure or kill you. NEVER attempt to adjust or repair electrical circuits unless you are familiar with the circuits and are qualified to work safely on the electrical circuits. ALWAYS lock out electrical circuits before attempting to work on this machine.
- Exposure to loud or long term noise can lead to permanent hearing loss. DO NOT operate this machine without hearing protection. ALWAYS wear hearing protection that meets Occupational Safety and Health Administration (OSHA) standards for noise attenuation.
- Compressed air can injure you. DO NOT work on compressed air systems without first disconnecting the source of compressed air. ALWAYS wear eye protection when performing maintenance on compressed air systems. ONLY authorized qualified personnel familiar with the compressed air system should perform maintenance on the compressed air system.

LBL-0129



LBL-0158



LBL-0127

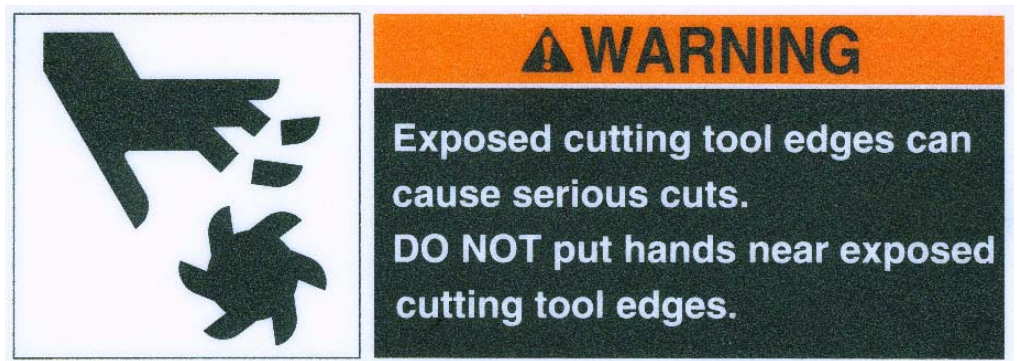

LBL-0130

⚠ WARNING



Flying objects from this machine may injure. **ALWAYS** wear safety glasses when operating this machine. Noise from this machine can damage hearing. **ALWAYS** wear ear protection when operating this machine. **DO NOT** operate this machine with the doors open or with enclosures removed. Lockout before servicing.

LBL-0163

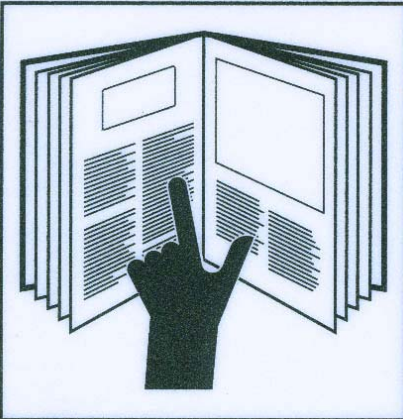

⚠ WARNING

To avoid serious injury or death to you or others:

- This machine must be operated by qualified personnel only.
- Read and completely understand Operator's Manual before operating this machine.

LBL-0126



LBL-0128

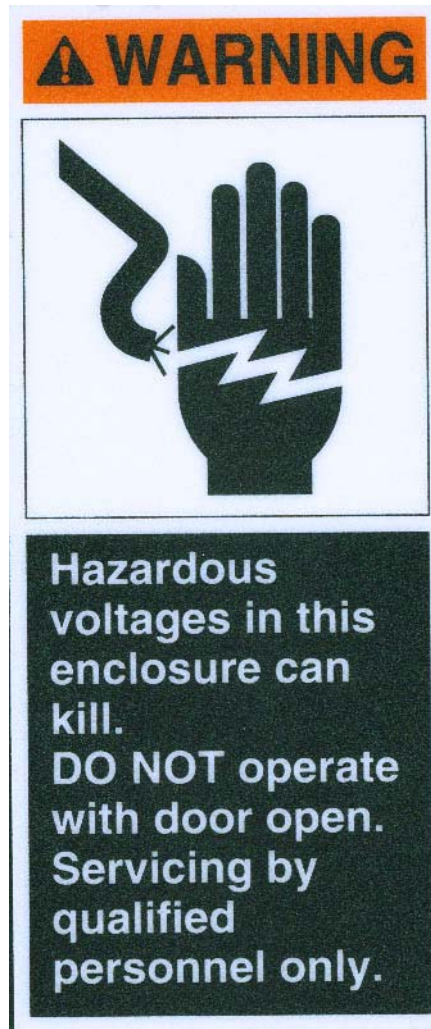

LBL-0125

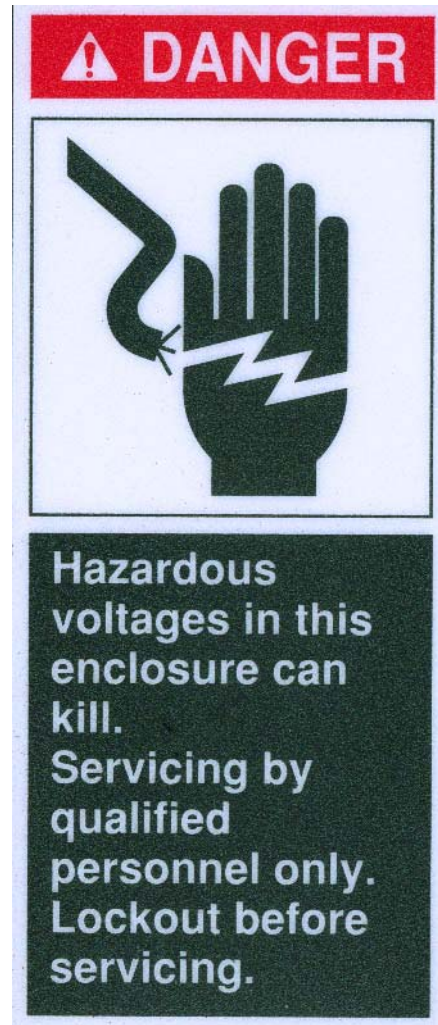

LBL-0235

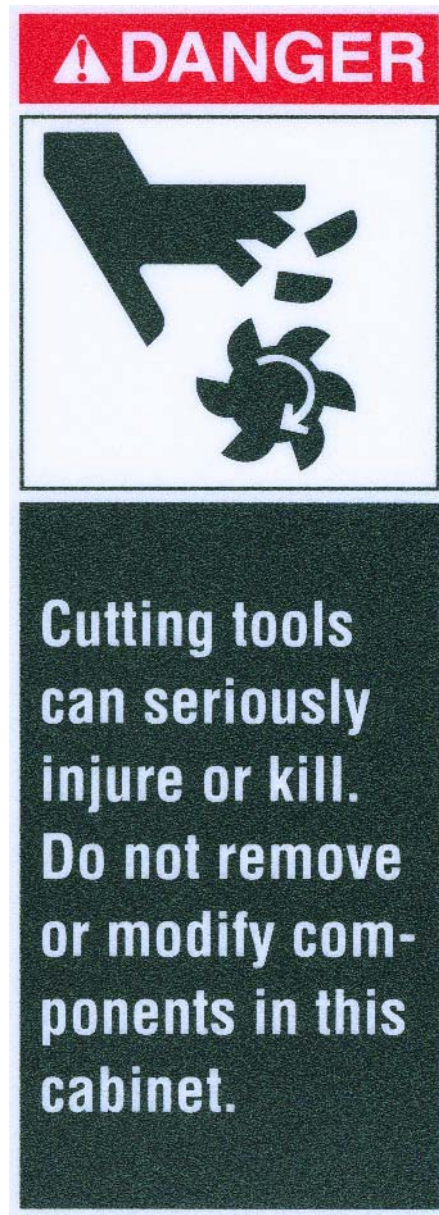

LBL-0131



LBL-0263



LBL-0187

FADAL VMC GROUNING REQUIREMENTS

FADAL VMC machines shall be grounded by any of the methods listed in article 250 of the National Electric Code. (see installation chapter of the FADAL VMC Maintenance Manual for details) The minimum grounding method recommended by FADAL is as follows:

- Grounding wire must be one continuous conductor, solid or stranded, no splices.
- Grounding wire must be copper wire with green insulation or a copper wire having green insulation with a yellow stripe.
- Grounding wire must be a No. 8 AWG or larger conductor.
- One end of this wire is connected to the protective earth bar in the back cabinet of the FADAL metalworking machine. The other end of the wire is connected to an applicable grounding lug in the power distribution panel of the building.

LBL-0234



LBL-0124



LBL-0040

MAINTENANCE AND RAIL LUBRICATION

DAILY

1. CHECK AIR PRESSURE (80-90 PSI).
2. WITH TOOL IN SPINDLE BLOW CHIPS FROM AROUND A.T.C. AND SLIDE. NEVER BLOW CHIPS FROM AROUND THESE AREA DURING AUTOMATIC TOOL CHANGE OR WITHOUT A TOOL IN THE SPINDLE.
3. REMOVE HEAVY CHIP BUILD UP FROM GUARDS AND WAY COVERS.
4. WASH A.T.C. AND MACHINE WORK AREA.

WEEKLY

1. CLEAN A.T.C. SLIDE.
2. CHECK AIR REGULATOR:
A: DRAIN WATER SEPARATOR
3. INSPECT ALL COOLING FANS. CLEAN IF NECESSARY.

EVERY 2 WEEKS

1. TO LUBE THE RAILS AND BALL SCREWS, GREASE EVERY LUBRICATION PORT AT THE SADDLE, TABLE AND HEAD WITH 4 PUMPS OF THE GREASE GUN.
A: USE MOBILTEMP SHC32 GREASE

LBL-0036

MAINTENANCE AND LUBRICATION

DAILY

1. CHECK AIR PRESSURE:
A: RIGHT REGULATOR 120 PSI MAX. (TOOL OUT ONLY)
B: LEFT REGULATOR 80-90 PSI
2. CHECK AIR FILTER:
A: DRAIN AND CLEAN WATER SEPARATOR.
3. CHECK WAY LUBE LEVEL (USE CASTROL MAGNA BD68, SHELL TONNA 68V OR MOBIL VACTRA #2 ONLY).
4. CHECK WAY LUBE SYSTEM FOR ADEQUATE FLOW TO ALL WAYS.
5. WITH THE TOOL IN SPINDLE BLOW CHIPS FROM AROUND A.T.C. AND SLIDE. NEVER BLOW CHIPS FROM THE AREAS DURING AUTOMATIC TOOL CHANGE OR WITHOUT A TOOL IN THE SPINDLE.
6. REMOVE HEAVY CHIP BUILD UP FROM GUARDS AND WAY COVERS.
7. WASH A.T.C. AND MACHINE WORK AREA.

WEEKLY

1. CHECK SPINDLE COOLER PUMP AND REFRIGERATION UNIT FOR PROPER OPERATION.
2. CLEAN A.T.C. SLIDE.
3. ACTIVATE (OPTIONAL) THRU-TOOL COOLANT SYSTEM FOR 2-3 MINUTES.
4. LUBRICATE Y AXIS TELESCOPING BALLSCREW COVER WITH WAY LUBE.
5. INSPECT ALL COOLING FANS. CLEAN IF NECESSARY.
6. CLEAN REFRIGERANT PUMP FILTER.

YEARLY

1. SERVICE WAY LUBE FILTER:
A: REPLACE BRONZE ELEMENT IN EXTERNAL FILTER.

SAFETY LABEL LOCATIONS

4020S



LBL-0234

LBL-0123



LBL-0129



LBL-0234



LBL-0123

LBL-0163



LBL-0235



LBL-0125



LBL-0128



LBL-0234

Fadal

5020a, 4020a, 4020,
3016L, 2216, 2016L,
15, 15xt, EMC



LBL-0128 LBL-0263



LBL-0126



LBL-0128 LBL-0263



LBL-0235



LBL-0125



LBL-0125



LBL-0235



LBL-0127

6030, 8030



LBL-0123



LBL-0128

LBL-0263



LBL-0235



LBL-0128

LBL-0263



LBL-0235



LBL-0126



LBL-0129



LBL-0124



LBL-0235



LBL-0125



LBL-0123

LBL-0163



LBL-0128



LBL-0128

LBL-0263



LBL-0235



LBL-0128

LBL-0263



LBL-0235

6535, 4525, 3020



LBL-0126



LBL-0036



LBL-0123



LBL-0128



LBL-0123



LBL-0128

LBL-0263

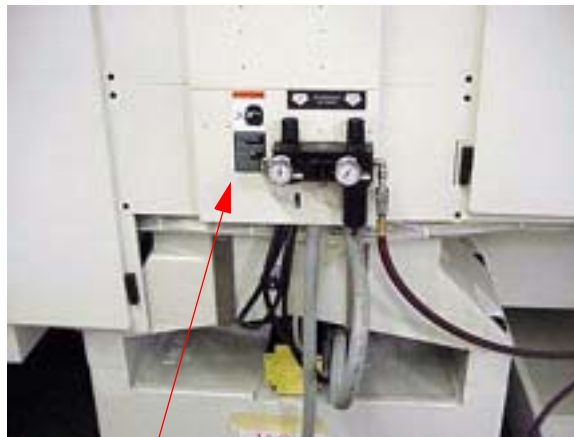

LBL-0126



LBL-0128

LBL-0263



LBL-0036



LBL-0235

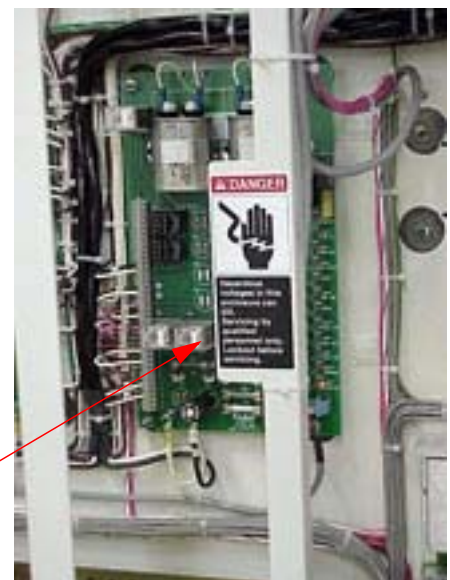

LBL-0125



LBL-0235



LBL-0125

CE SAFETY LABELS

LBL-0431 small (CE)
LBL-0434 large (CE)

**Cutting of Fingers or Hand / Rotating Cutter**

Cutting tools can seriously injure. Never place any part of your body near rotating tools. Do not operate this machine unless the doors are closed and the door interlocks are working.

LBL-0432 (CE)

**Hand Entanglement / Belt Drive**

Rotating pulleys and belts can seriously injure. Never place any part of your body near rotating or moving parts. Always insure that guards are in place before operating this machine.

LBI-0132 (CE)



Electric Shock / Electrocutation

Hazardous voltages in this enclosure can kill. Do not operate with the door open. Servicing should be done by qualified personnel only. Lockout the power before servicing.

LBL-0435 (CE)



Flying Debris and Loud Noise

Flying objects from this machine may injure. Always wear safety glasses when operating this machine. Do not operate this machine with the doors open or the enclosures removed. Also, noise from this machine can damage hearing. Always wear ear protection when operating this machine.

LBL-0460 (CE)



Flying Debris

Flying debris and compressed air can cause eye injuries. Do not perform maintenance on pressurized systems. Disconnect the air source before performing maintenance. Always wear eye protection when performing maintenance on compressed air systems.

LBL-0430 (CE)



Skin Puncture / Pressurized Air

Compressed air can seriously injure. Do not perform maintenance on pressurized systems. Disconnect air source before performing maintenance. Always wear eye protection when performing maintenance on compressed air systems.

LBL-0436 (CE)



Leg or Body Entanglement / Auger

Auger can serious injure or kill. Keep body parts out of the auger system at all times. Turn off the machine and lockout the power before doing maintenance inside the enclosure.

LBL-0433 (CE)



Hand Crush / Moving Parts

Automatic pallet changer door will crush hands. Stand clear when the door is closing.

LBL-0443 (CE)



Hand Crush / Force from Side

Automatic pallet changer can crush hands. Do not place hands or any part of the body in the path of a moving pallet.

PROHIBITIONS

LBL-0441 (CE)

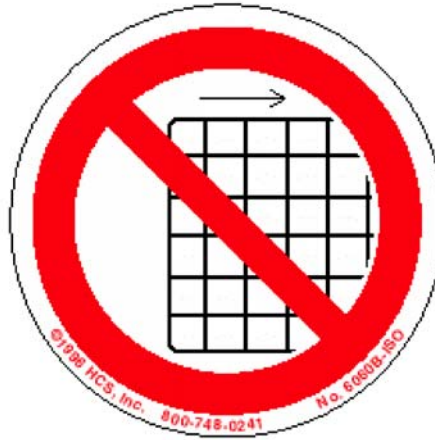

Do Not Operate with Guard Removed

Do not operate this machine with the doors open or the guards removed. Moving machinery and rotating cutters can seriously injure or kill.

REQUIRED ACTIONS

LBL-0439 (CE)



Wear Eye Protection

Flying objects may injure. Always wear safety glasses when operating this machine.

LBL-0440 (CE)



Wear Ear Protection

Noise from this machine can damage hearing. Always wear ear protection when operating this machine.

LBL-0442 (CE)



Consult Operator's Manual

Read and understand the Operator's Manual before operating this machine. This machine must be operated by qualified personnel only,

LBL-0438 small (CE)

LBL-0437 large (CE)



Lockout Electrical Power

Whenever servicing the machine, turn the machine off and lockout the power. Turn off the machine and lockout the power before working in this cabinet.

CE SAFETY LABEL LIST AND LOCATION

Location	Domestic or old Labels	CE Labels
ATC Slide Arm Plate	LBL-0129	LBL-0432 (1009B-ISO), LBL-0438 (6011B-ISO)
Spindle Belt Guide (inside spindle cover)	LBL-0129	LBL-0432 (1009B-ISO), LBL-0438 (6011B-ISO)
Front by Pendant	LBL-0123, LBL-0163	LBL-0435 (3002A-ISO), LBL-0439 (6040A-ISO), LBL-0440 (6041A-ISO), LBL-0442 (6126A-ISO)
Tool Turret Cover	LBL-0136	LBL-0136 (revised)
Tool Changer Cover	LBL-0127	LBL-0434 (1007A-ISO)
Head (Spindle) Cover	LBL-0130 LBL-0137,-0138, or -0139	LBL-0435 (3002A-ISO), LBL-0439 (6040A-ISO), LBL-0440 (6041A-ISO) LBL-0137,-0138, or -0139 (revised)
Right Front Door	LBL-0124 LBL-0140	LBL-0431 (1007B-ISO), LBL-0441 (6060B-ISO) (LBL-0140 deleted after doors locked)
On Control, Transformer, and Pendant Cabinet Doors	LBL-0128, LBL-0131	--- LBL-0131 (6010A-ISO)
Inside of Control, Transformer, and Pendant Cabinets	LBL-0125 LBL-0235	LBL-0131 (6010A-ISO), LBL-0437 (6011A-ISO) (B size labels used in Slant Control cabinet - LBL- 0461, LBL-0438)
Grounding Labels	LBL-0133 (chassis ground) LBL-0186 (Protective Earth input)	LBL-0133, LBL-0186 (same)
Flood, Mist, RS-232 Outlets	LBL-0192, LBL-0188, LBL-0189	LBL-0192, LBL-0188, LBL-0189 (same)
On Chiller Cabinet	LBL-0300	LBL-0300 (same, 3 languages)
Chiller Outlets	LBL-0191, LBL-0190	LBL-0191, LBL-0190 (same)
CNC Power Button	LBL-0038	LBL-0038 (same)
Air Regulator	LBL-0126 LBL-0146	LBL-0430 (1120B-ISO) LBL-0460 (3021B-ISO) keep LBL-0146
Maintenance & Pull Stud labels	LBL-0036, LBL-0037	LBL-0036, LBL-0037 (same) Translated versions must be used for non-English speaking countries.
CE	---	LBL-0141
Left Side	LBL-0123	----
On Control and Transformer Cabinet Doors	LBL-0263	----

Main Disconnect, Aux. Disconnect, and Motor Starter Enclosures	LBL-0132	LBL-0132 (6010C-ISO)
Main Disconnect	LBL-0134, LBL-0135	LBL-0134 (I5007a-D), LBL-0135 (I5008a-D)
Next to Main Disconnect (Inside)	LBL-0187	keep LBL-0187 Translated versions must be used.
Main Disconnect inputs (U,V,W)	LBL-0142, LBL-0143, LBL-0144	LBL-0142, LBL-0143, LBL-0144 (same)
Auger - by left and right access panels, lower left of front door	LBL-0234	LBL-0436 (5004A-ISO)
Pallet Changer Base (front & rear)	----	LBL-0443 (1042B-ISO)
Pallet Changer Door	LBL-0158	LBL-0433 (1099A-ISO)

TABLE OF CONTENTS

TABLE OF CONTENTS i

Overview 1

- 1.1 Introduction 1
- 1.2 Digital Control System 2
- 1.3 Digital Drive Converter System 2
 - 1.3.1 CCU 2
 - 1.3.2 CCU Interface Panel 3
 - 1.3.3 Axis Extension Module 7
- 1.4 Power Supply 7
- 1.5 Pendant Components 8
 - 1.5.1 MCP 8
 - 1.5.2 HMI 8
 - 1.5.3 CNC Keyboard 9
 - 1.5.4 MPG 10
- 1.6 System Components and Parts 10
 - Hand –Held Unit (Remote MPG) – Description of elements. 12

Control Components 13

- 2.1 Replacement of Modules 13
 - 2.1.1 Reactor and Line Module Replacement 13
 - 2.1.2 Replacing the E/R Module 18
 - 2.1.3 CCU1 Module Replacement 18
 - 2.1.4 Power Module Replacement 19
 - 2.1.5 Connecting Modules 21
- 2.2 Wiring Connections 22
 - 2.2.1 CCU1 Module Connections 22
 - 2.2.2 Simodrive 611 Module Connections 24
 - 2.2.3 Reactor/Line Filter Module Connections 25
 - 2.2.4 Power Module Connections 26
- 2.3 Replacing the 24V Power Supply 26
- 2.4 Replacing the I/O Module 27
- 2.5 Replacing the 2010-0 Board 28
- 2.6 Replacing Fadal 5 VDC Power Supply 32
- 2.7 Replacing Pendant Components 33
 - 2.7.1 2020 Power Distribution Board 34
 - 2.7.2 MPG Panel 34

2.7.3 MCU Panel	35
2.7.4 PCU 210	35
2.7.5 Keyboard	35
2.7.6 Wiring Connections	35
Power On Procedure	37
Alarms	37
1000 Series Alarms	37
2000 Series Alarms	37
3000 Series Alarm	40
4000 Series Alarm	41
6000 Series Alarm	47
8000 Series Alarm	49
10000 Series Alarm	49
MMC 100 Messages	56
Machine Operating Area	57
Fadal 3020 PLC Alarm Messages	60
Action List	69
Compensation	79
5.1 Cold Start Position	79
5.1.1 SET OFFSETS	79
5.2 Spindle Belt	80
5.2.1 M83 Program	80
5.2.2 M84 Program	81
5.3 Axis Backlash	81
5.3.1 COMP_VALUES_n	81
5.4 Reset Tool Magazine	84
5.4.1 TC_BASE	84
MMC100 Software Update	87
General Information	87
List of Components	87
Tools Required	88
MMC100 Update Procedure	88
3. Recording Original Cold Start Position, Backlash Data and Gain Settings	89
7.Back Up Other Data	97
DATC Hardware Update 1.7.2 (or above)	118
General Information	118
Tools Required	118
1. Replace Hardware for DATC	118
MMC103 Software Update v1.7.2 (or above)	119

General Information 119

List of Components 119

Tools Required 120

MMC103 Update Procedure 120

 3. "Get" Offset and Backlash Data 121

 10.Back Up Hard Disk Files 143

 12.Install New Pre-imaged Hard Disk 145

 13. Display (HMI) Firmware 146

DATC Hardware Update v1.7.2 (or above) 149

General Information 149

Tools Required 149

 1. Replace Hardware for DATC 149

Parameters 151

Setting Options on the Fadal Siemens 151

Setting the Bits 152

How To set the number of tools in the ATC magazine 152

The Options program 153

Fadal Siemens Spindle Parameters 160

C-axis default ratio 162

Siemens 50 Taper 163

MACHINE OVERVIEW 163

Troubleshooting 169

.1 Introduction 169

.2 The Alarms and Messages Line 169

.3 The Alarms/Messages Page 169

.4 The Central Control Unit (CCU) Front Panel 170

.5 The In-feed/Regeneration (I/R) Module 172

.5.1 The I/R Module 173

How to monitor the DATC interface. 174

HOW TO RE-SET THE TOOL MAGAZINE LOCATION. 175

Section 01: Overview

1.1 Introduction

The SINUMERIK 810D/840D is a digital CNC (Computerized Numerical Control). Figure 1-1 shows an 810D digital control system. Its input and output is based on binary numbers, as opposed to continuously varying current flow and voltage levels, as on analog controls. When using analog controls in a machine tool position control operation, the motors take in current or voltage (for example, 0 to 30 amps or 0 to 100 volts) to run at a certain speed and for a certain length of time in order to motion to a preset point.

In a digital control, currents and voltages in a control loop are generated in digital form by a digital encoder, for example, a series of ones and zeroes or a series of 0 volt and +5 volt signals. Motor current consumption is converted into numbers at a very early stage in the control loop. These numbers are then input into a computer which, in turn, takes these numbers and manipulates them, perform calculations with them, or filters them to obtain an output. The output is the instructions that tell the machine what to do.

A digital control has several advantages over an analog control.

For instance, it is more accurate. It only needs to sense the difference between two clearly distinguishable states. For example, a slight voltage fluctuation would affect the result in an analog control, but a slight voltage fluctuation would not affect a digital control because the control could still easily distinguish the "0" state from the "1" state of any circuit element.

Other advantages include the ability to share data more easily with other devices in the control, digital data is less prone to noise, and digital signal processing can be used to filter the data and correct problems (for example, resonance frequency from a mechanical system) that can affect movement.

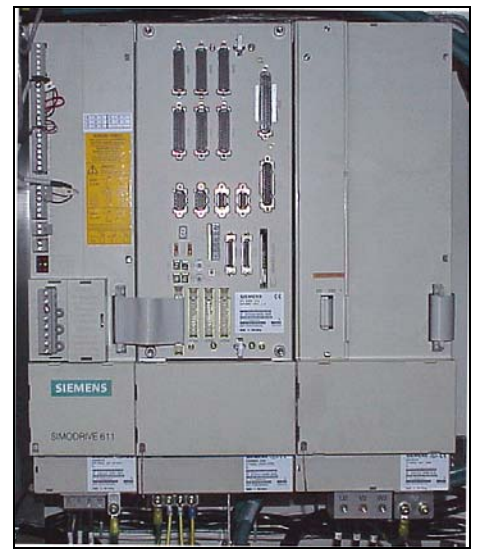

Figure 1-1. The 810D digital drive converter system.

1.2 Digital Control System

The typical digital control system is comprised of a digital drive converter system, power supply, operator panel, CNC full keyboard, machine control panel, and motors for digital converter system (see Figure 1-2).

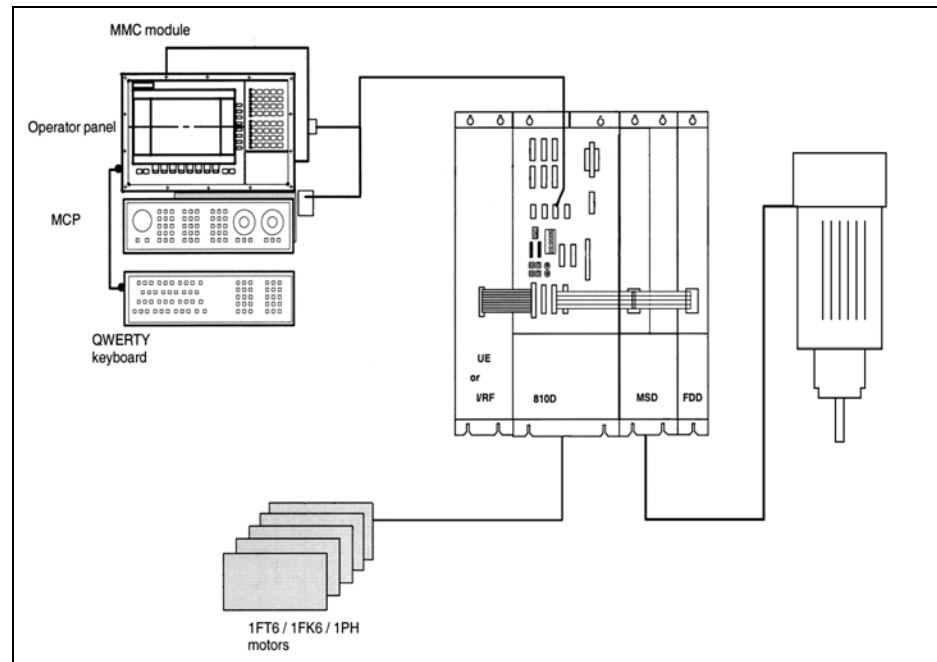

Figure 1-2. The basic 810D controls system.

1.3 Digital Drive Converter System

The digital drive converter system is housed inside an electronics cabinet mounted on the backside of the VMC (Vertical Machining Center). There are two main components that make up the digital drive converter system are the CCU and the SIMODRIVE 611D axis extension module.

1.3.1 CCU

The CCU (Compact Control Unit) consists of two major components, as shown in Figure 1-3. One component is the CCU box. This box contains a fan (for cooling), two to three integrated power sections, and a slot for the CCU module. The other component is the CCU module. It consists of the NCK (Numerical Control Kernel), the PLC (Programmable Logic Control), and six one-motor control sections (three for the power sections in the CCU box and three for external power module). Figure 1-4 shows a diagram of these three sections of the CCU module. The CCU module performs all CNC, PLC, communication, and control tasks.

The NCK is a computer that decodes the part program and sends the commands to the appropriate drives. The drives can be internal to the 810D, or external. The drives take the commands and position the axes accordingly.

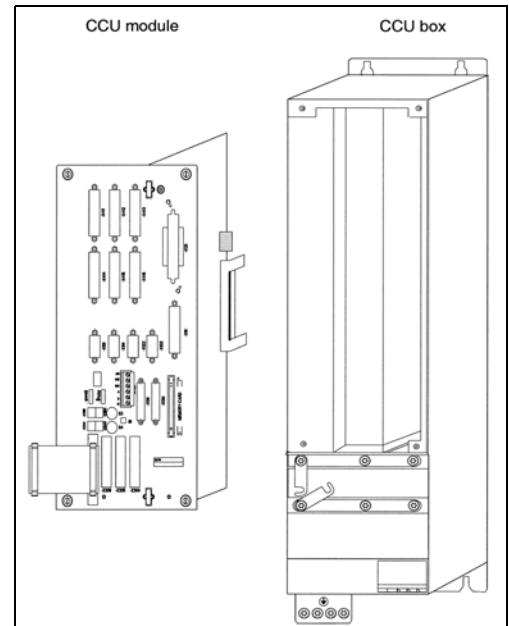

Figure 1-3. The two major components make up the 810D. They are the CCU box and the CCU module.

The PLC is also a computer. It is an open ended sequential logic, programmable, computerized controller. The main characteristic of the PLC is the flexible set of inputs and outputs that can be programmed to search for incoming signals and respond with outputs based on logical conditions preset by the machine tool manufacturer.

The PLC is needed to control the rest of the machine coordination with the NCK. For example, the PLC can be programmed to send a signal to the NCK to stop program execution in case the hydraulics are not on. The PLC also controls equipment, such as coolant pumps, pallet changer, and work lights.

In the operation of the work light, for example, pressing the work light button sends a signal to a preset input in the PLC. The program inside then takes that signal and compares the state against a logical statement (something like “if work light button is pressed, then turn on work light”) and sends the appropriate output, like a voltage to a relay that turns the light on.

1.3.2 CCU Interface Panel

All the necessary interfaces for receiving feedback from the motor and other components of the system are on the front panel of the CCU module. But, unlike other stand-alone control modules, the control sections of the CCU have only one feedback connector, instead of two. If a second measurement system is needed, one of the available control sections has to be used for feedback input. For example, if control section four is being used as a second

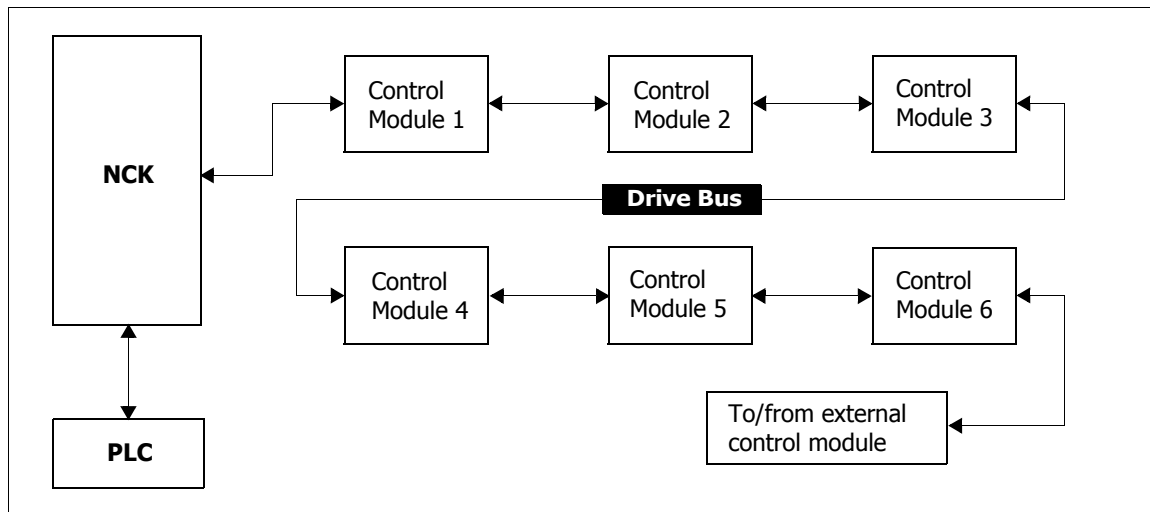

Figure 1-4. The three sections of the CCU module are the NCK, PLC, and one-motor control sections.

feedback, and assuming control sections one through three are also being used, then it can no longer be used to control an additional motor. The motor would have to be connected to the next available control section; in this case, it is control section five.

The following list is a description of the SINUMERIK 810D control module interface connections from Figure 1-5:

- a. **X411 - X416** are the measuring system connections for indirect and direct position sensing.
- b. **X121** is the I/O interface (cable distributor for handwheel and probe).
- c. **X113** and **X114** are reserved.
- d. **X122** is the MPI interface (187.5 kBaud).
- e. **X102** is the PROFIBUS-DP interface (as of 6/99).
- f. **X111** is the P bus (PLC I/O bus) connection of S7-300 I/O and single I/O module.
- g. **H3** (not labeled) is the 7-segment display for software supported output of test diagnostic signals.
- h. **X431** is the terminal block for the connection of starting lockout, pulse enable (all drives), and external zero marker (BERO).
- i. **H1** and **H2** (not labeled) are error and status LEDs.
- j. **X130** is the SIMODRIVE 611D drive bus interface and I/O extension.

- k. PCMCIA memory card slot (shown with memory card inserted).
- l. **X341**, **X342**, **X351**, and **X352** are the DAC test sockets.
- m. **S3** is the NCK start-up switch.
- n. **S4** is the PLC operating mode switch.
- o. **X151** is the device bus interface (power supply).
- q. **X304 - X306** are the axis extension connections.

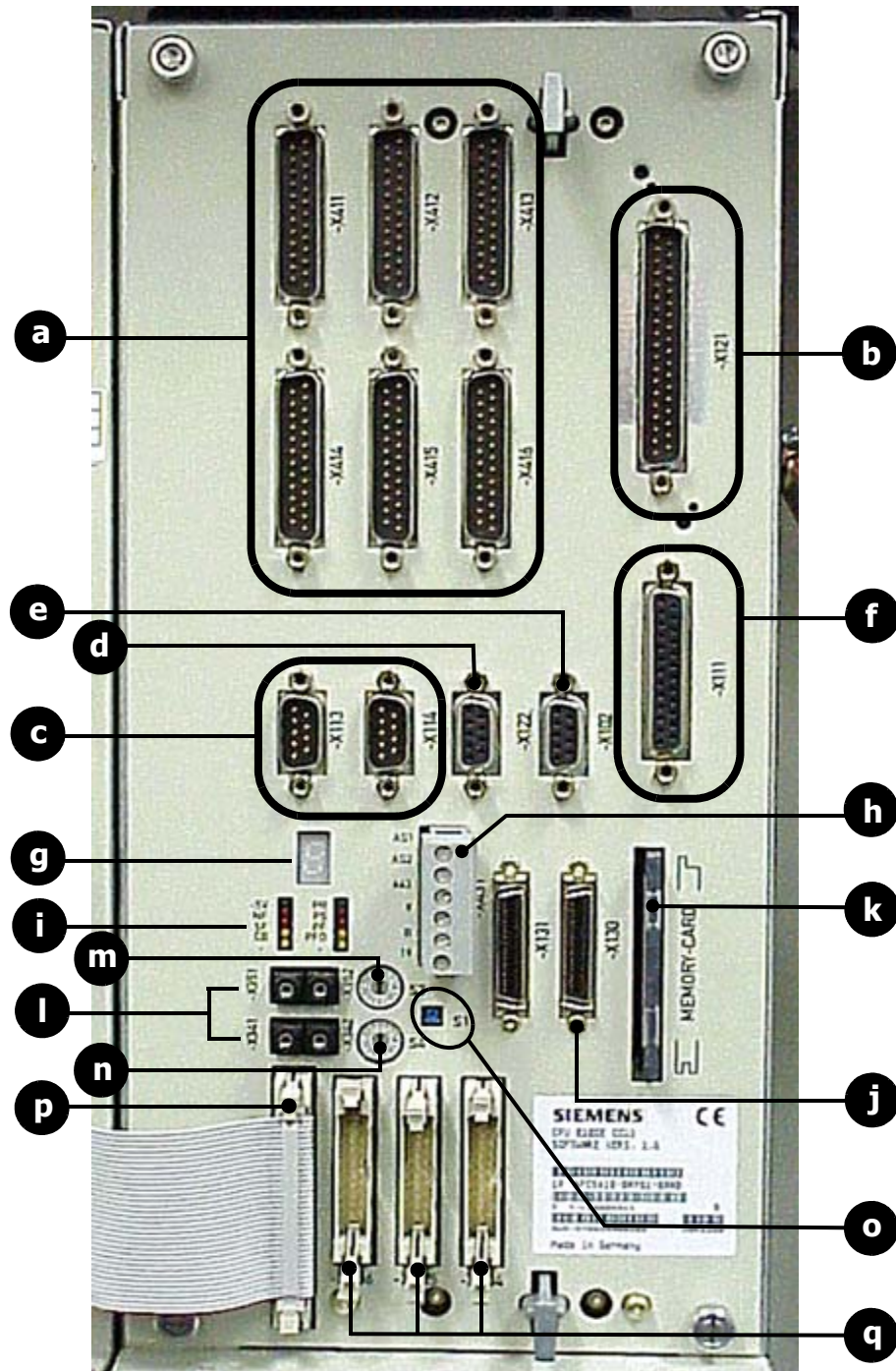

Figure 1-5. SINUMERIK 810D control module interfaces.

1.3.3 Axis Extension Module

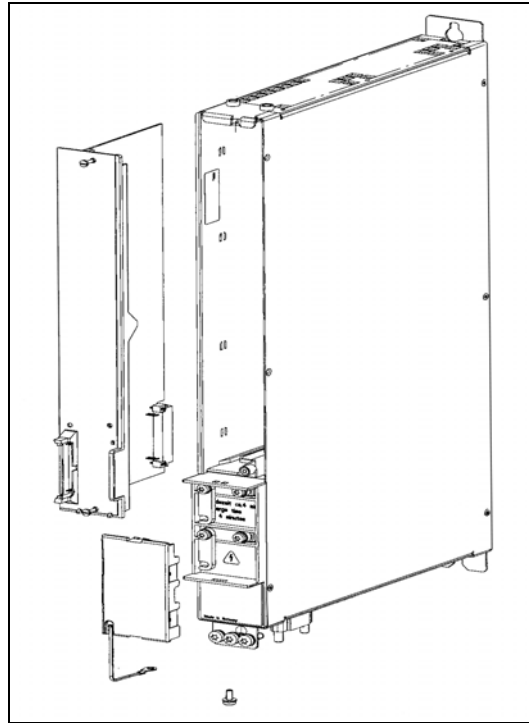

Figure 1-6. The 611D control module and power module.

The SIMODRIVE 611D module, mounted to the left of the CCU, consists of an axis extension control module and a power module (See Figure 1-6). The axis extension control module has everything that is required to interface with the rest of the drive system, as well as position and speed feedback connections. Both the motor encoder and an optional second measuring system (linear scale or second encoder) plug into the drive. The motor encoder also provides the rotor logic (brushless DC motors) and speed feedback.

The power module has one primary responsibility. It takes the power from the DC link and converts it to the required AC output that is needed to run the motor(s). In addition, the power

module also has a number of sensors for current and temperature feedback to the control module.

The DC link voltage is generated from the power supply module. This module provides power to the drives, as well as, the different “logic” voltages that are needed for the electronics.

In general, the control module takes commands from the NCK and sends information back to itself by means of the drive bus. Each control module controls one or two motors for position, speed, and current consumption.

1.4 Power Supply

The I/RF (Infeed Regenerative Feedback) module is the power supply for the SINUMERIK 810D control and drives. It is mounted to the right of the SINUMERIK 810D. This power supply generates a ± 15 VDC and ± 24 VDC output for the electronics of the SINUMERIK 810D and has a DC link voltage of 600 VDC (+300 VDC and -300 VDC) for a regulated I/R module and 550 VDC for an unregulated UE module.

1.5 Pendant Components

Mounted on the pendant are the components that create the machine interface system for the operator. The system components consists of a MCP, HMI, CNC keyboard, and manual pulse generator (See Figure 1-7).

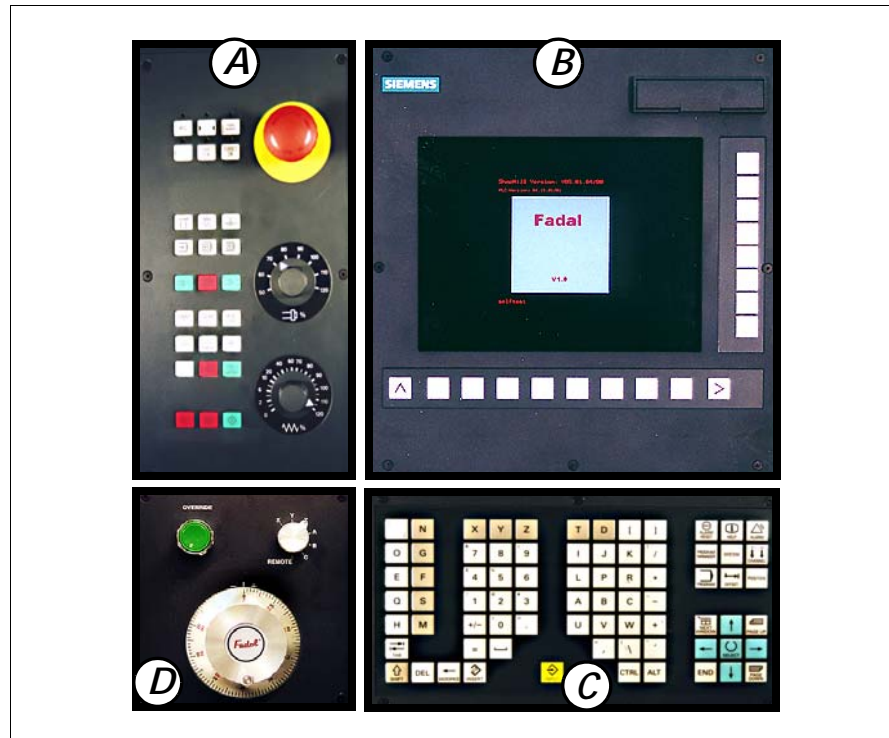

Figure 1-7. The pendant is comprised of four operator interface components: (A) MCP-Machine Control Panel, (B) HMI-Human Machine Interface, (C) CNC keyboard, (D) MPG-Manual Pulse Generator.

1.5.1 MCP

The MCP (Machine Control Panel) controls the physical functions of the machine. It is mostly used in conjunction with the HMI, CNC keyboard, and MPG. One simple example of an MCP function can be turning the coolant on and off. Another common function is referencing the axes of the machine.

The makeup of the MCP consists of several groups of keys, referred to as hard keys, a spindle control dial, a feedrate dial, and an EMERGENCY STOP button.

1.5.2 HMI

The HMI (Human Machine Interface) is a graphical display system that provides the interfacing between the operator and the control. It consists of a bank of vertical and horizontal soft keys, and a TFT flat display screen. The HMI is the main component of the pendant because it provides both input to and output from the control. Some of the functions of the HMI are it displays

event and alarm messages, allows a user to control and supervise a job process by means of menus, gives the user ability to load programs, and gives users access to both the PLC and NCK.

The HMI communicates with the PLC and NCK via the MPI (Multi-Port Interface) bus. As illustrated in Figure 1-8, the MPI connects the NCK, the PLC, and the HMI. There is a constant exchange of information between the NCK and the drives through the MPI bus. The NCK, the PLC, and the HMI are also individual computers that need to exchange data on a constant basis through the MPI (Multi Port Interface) bus.

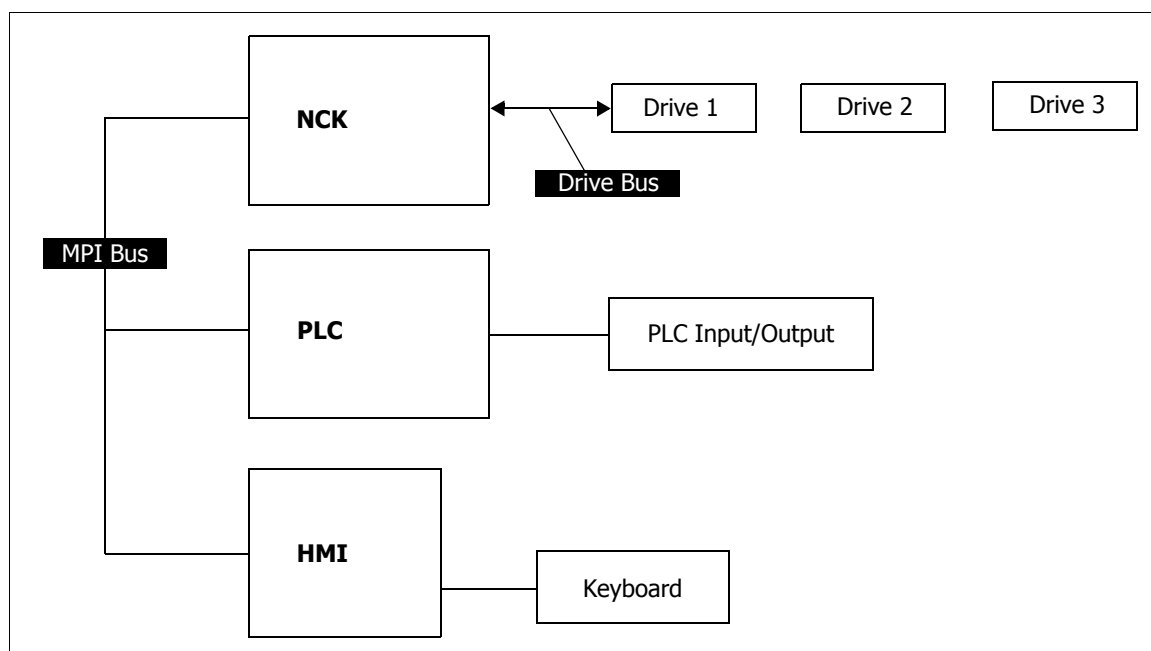

Figure 1-8. The MPI bus is the communication link for the HMI, PLC, and NCK.

1.5.3 CNC Keyboard

The CNC keyboard is installed below the HMI. It is not laid out like a standard QWERTY keyboard but its function is essentially the same as a QWERTY keyboard. It is used for functions such as, MDA data input, programming manual data entry, Shopmill programming, and advanced operator parameters programming. When the control is in PC mode, the keyboard is used in the same way as a PC keyboard. The CTRL key, ALT key, and arrow keys, for example, are used to navigate through Windows.

1.5.4 MPG

The MPG (Manual Pulse Generator), installed in the lower left corner of the pendant, is used to manually jog the axes of the machine. The MPG is enabled by pressing the “MPG” hard key, located on the MCP. Jogging an axis is accomplished by selecting an axis with the selector knob and then turning the dial clockwise or counterclockwise to move the selected axis.

1.6 System Components and Parts

Component	Part No.	Description
MCP	CTR-0127	Machine Control Panel
PCU 210	CTR-0126	Flat panel display - Solid State
Membrane keyboard	ELE-1094	Keyboard for PCU 210
OP032S	CTR-0128	Flat panel display for MMC103 (PC based front end)
DIN Keyboard	CTR-0129	Keyboard for MMC103 (PC based front end)
MMC 103	SFT-0017	PC based front end (Hard Drive)
Floppy Drive	ELE-1174	Floppy Drive for MMC103 (PC based front end)
ISA/PCI Adapter	ELE-1175	Expansion adapter for ISA/PCI cards - MMC103
Power Supply 16kW	ELE-1083	Power Supply 15 HP Spindle - Low voltage power supply for electronics
Reactor 16kW	ELE-1084	Line Reactor 15HP Spindle
Filter 16kW	ELE-1085	Line Filter 15HP Spindle
Overvoltage Lim. Module	ELE-1087	Line Voltage Surge Protection Module for Power Supply
Power Supply 28kW	ELE-1165	Power Supply 20 HP Spindle - Low voltage power supply for electronics
Reactor 28kW	ELE-1166	Line Reactor 20HP Spindle
Pulsed Resistor	ELE-1167	Pulsed Resistor for 28kW Power Supply
Filter 28kW	ELE-1168	Line Filter 20HP Spindle
CCU Box	ELE-1088	Subrack for holding the CCU1 with 3 integrated power modules
CCU1	ELE-1089	“Central Unit containing NCK, PLC, communications, digital standard control”
Compact I/O	ELE-1093	“PLC I/O module 64 In, 32 Out”
Power Supply 24V-5A	ELE-1095	24VDC power supply - for PCU 210
Power Supply 24V-10A	ELE-1134	24VDC power supply - for MMC 103

Axis Expansion Board	ELE-1091	For installation of a 611 power module.
45A Power Module	ELE-1090	15HP Spindle Power Module
60A Power Module	ELE-1164	20HP Spindle Power Module
9/18A Power Module	ELE-1196	Single Axis Power Module - 4th Axis
2 * 9/18A Pwr Module	ELE-1161	Dual Axis Power Module - 4th & 5th Axes
611 Controller Board	ELE-1155	611D Standard controller board for axis expansion
Servo Motor - Lin. Axis	MTR-0167	Servo motor for linear axis -XYZ
Servo Motor - Rot. Axis	ELE-1157	Servo motor for rotary axis -AB
MPI cable	WIR-0745	MPI cable - 5 meters. Between CCU and front panel
PLC I/O cable	WIR-0740	"PLC I/O cable, 2.5 meters - Between CCU and compact I/O"

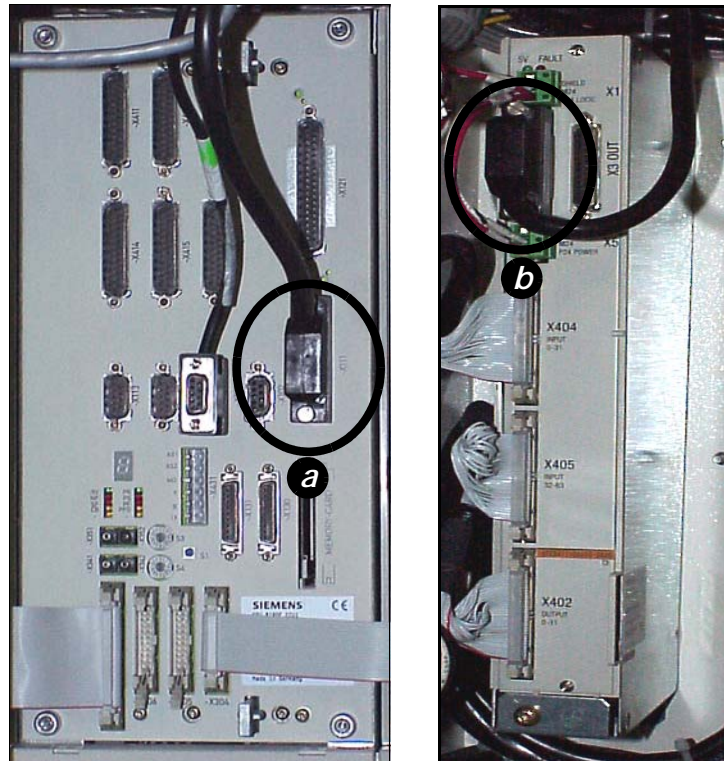

Figure 1-9. (a) WIR-740 cable connection at CCU front panel.
(b) WIR-740 cable connection at compact I/O module.

**Hand –Held Unit
(Remote MPG) –
Description of
elements.**

1. Remote MPG wheel. Activated by selecting the “Remote” position in the main axis selector switch in the machine control panel and the MPG mode. Generates square-wave pulses for the incremental movement of the selected axis.
2. Remote axis selector switch. Selects the active axis. The active axis can be jogged or moved incrementally. X, Y, Z, 4th and 5th axis available.
3. + key. Moves the active axis in the positive direction. If in jog, the axis moves as long as the key is pressed. If in incremental, the axis moves one increment in the positive direction.
4. - key. Moves the axis in the negative direction. . If in jog, the axis moves as long as the key is pressed. If in incremental, the axis moves one increment in the negative direction.
5. ~ key (Rapid traverse override key). Pressed together with the + or – key the active axis moves at rapid jog speed (only in jog mode).
6. F1 key. Works exactly as the “TOOL IN/OUT” key in the machine control panel. Active only when the main axis selector switch is in the “Remote” position.
7. F2 key. Toggles between MPG and JOG mode when the remote MPG is activated.
8. F3 key. Selects the incremental multiplier for incremental movements. When the remote MPG is selected, the multiplier defaults to x1 (1 times .001 mm or .0001 in). By pressing F3, the incremental multiplier changes to x10, x100 and variable multiplier in succession. If F3 is pressed further, the cycle repeats.
9. Enabling button (back of the unit). Electrically connected in parallel to the “override” button in the machine control panel, it allows to move the axes with the doors open.
10. Emergency stop. Connected in series with the E-stop circuit in the machine. Stops the machine in case of an emergency.

Section 02: Control Components

2.1 Replacement of Modules

2.1.1 Reactor and Line Module Replacement

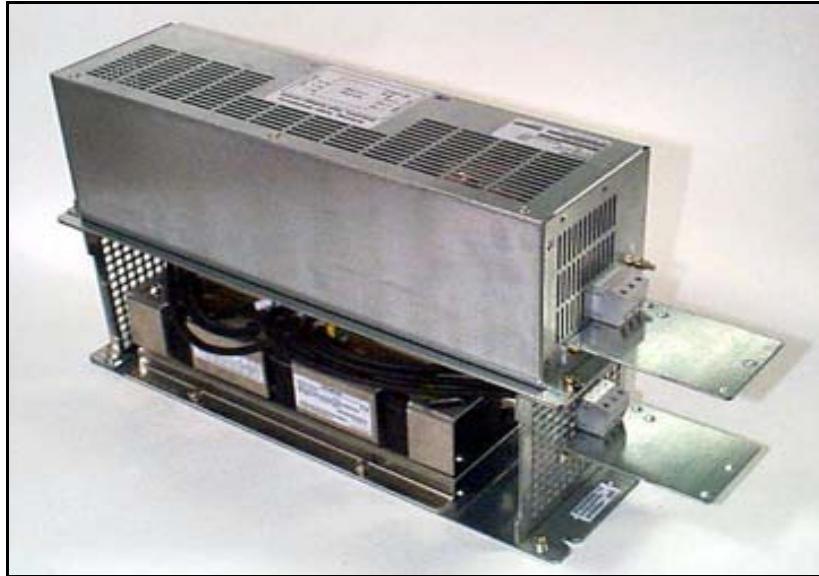

Part Numbers:

ELE-1084 Reactor, Siemens, 16KW
ELE-1085 Line Filter for I/R
ELE-1086 I/R Module, 16KW (6 sheet metal parts)

Tools Required:

Torx driver set
Flat Tip Screwdriver
Nut Driver

NOTE: To remove components for repair or replacement, follow the assembly instructions as necessary, in reverse order, until the component has been disassembled to required level to conduct the repair.

1. Attach the Reactor Module (ELE-1084) to the back plate (ELE-1086 one of six parts) with four M6 flathead torx screws, flat and lock washers, and nuts.



2. Attach the upper ventilation grid to the upper portion of the back plate with two M6 flathead torx screws.

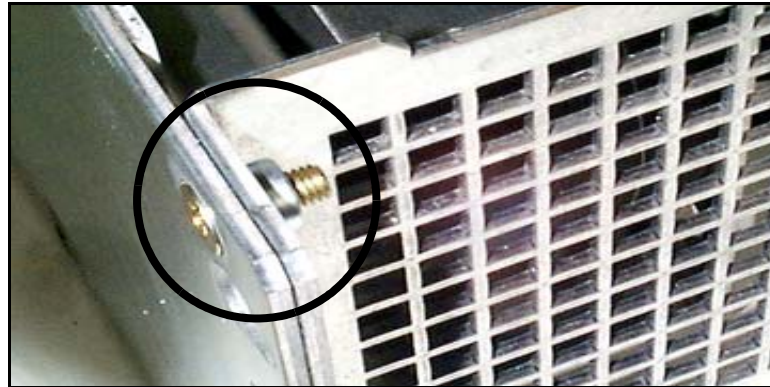

3. Pull apart the output terminal and install it on the lower ventilation grid.

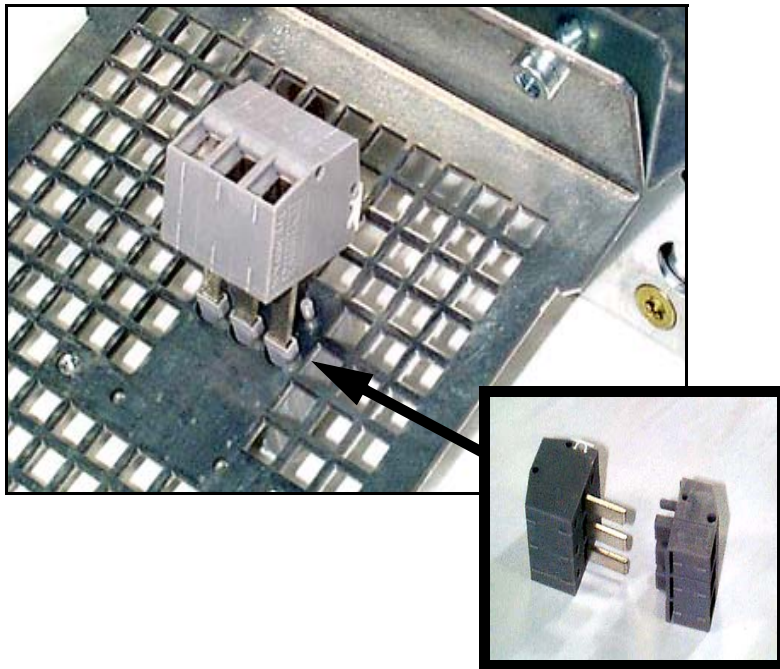

4. Attach the lower ventilation grid to the lower portion of the back plate with two M6 flathead torx screws.



5. Connect wires from the Reactor Module (ELE-1084) to the output terminal.

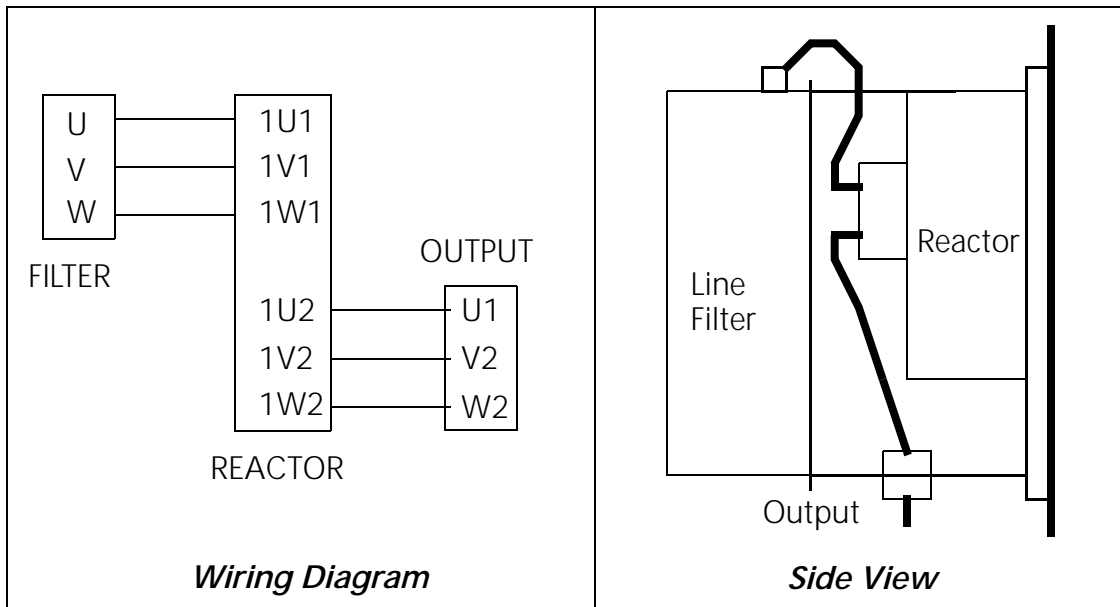

Connect the wires for the Line Filter to the Reactor and feed them out through the access on the top ventilation grid.

6. Attach the Main Line Filter and its mounting plate to the Reactor Module assembly with four M6 round head torx screws.

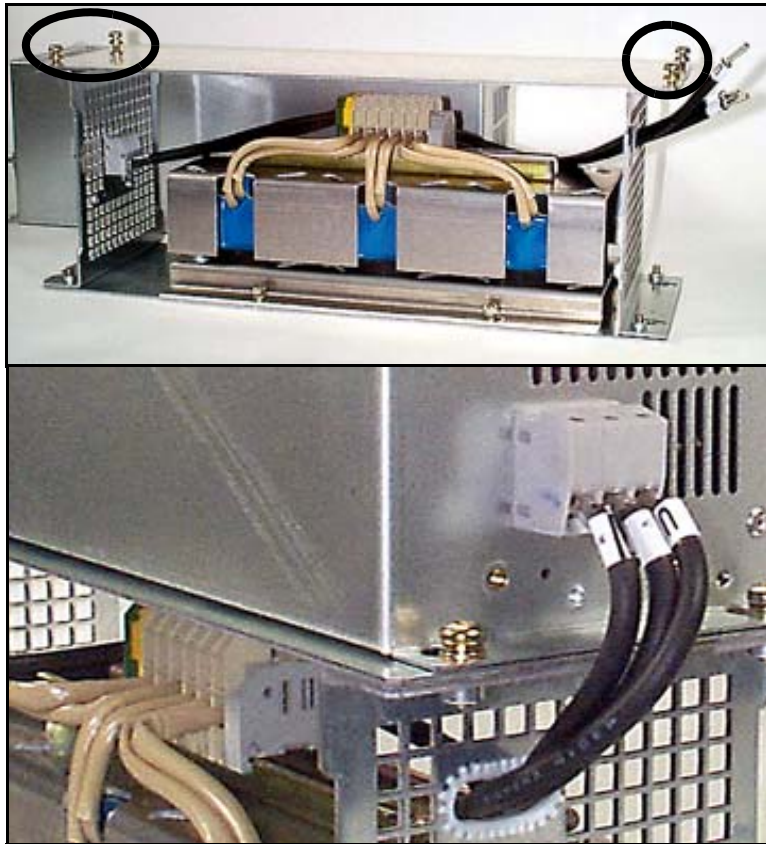

Connect the wires from the Reactor to the Line Filter.

7. Attach the two wire shields to the bottom of the assembly using two each M4 torx screws.

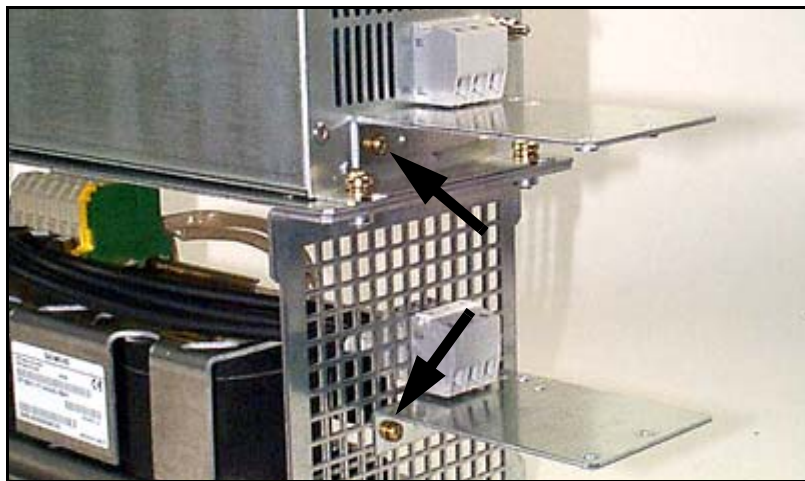

8. Mount the Reactor and Line Filter assembly on the left side of the mounting bars with four 1/2-20 x 3/4" torx screws.

2.1.2 Replacing the E/R Module

Parts Numbers:

ELE-1083 Simodrive E/R Module Int. 16/21KW
ELE-1087 Over Volt Limit Module

Tools Required:

Torx driver set

NOTE: To remove components for repair or replacement: Follow the assembly instructions as necessary, in reverse order, until the component has been disassembled to required level to conduct the repair.

1. Attach the E/R Module (ELE-1083) to the mounting bars with four 1/4-20 x 3/4" torx screws. Located immediately to the right of the Reactor Line Filter Assembly.
2. Remove the 8 position terminal block from X181 on the E/R module, plug the Over Volt Module (ELE-1087) onto the front of the Simodrive Module. Install the 8 position terminal block into the over voltage module.

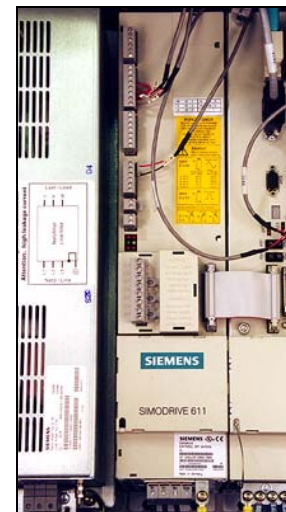
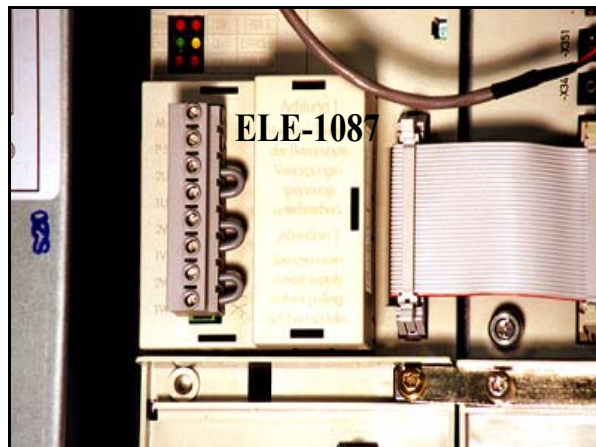

2.1.3 CCU1 Module Replacement

Parts Numbers:

ELE-1088 CCU box 810D
ELE-1089 CCU1 unit

Tools Required:

Torx driver set
Flat Tip Screwdriver

NOTE: To remove components for repair or replacement: Follow the assembly instructions as necessary, in reverse order, until the component has been disassembled to required level to conduct the repair.

1. Attach the CCU box (ELE-1088) to the mounting bars with four 1/4-20 x 3/4" torx screws. Locate immediately to the right of the Simodrive Module.

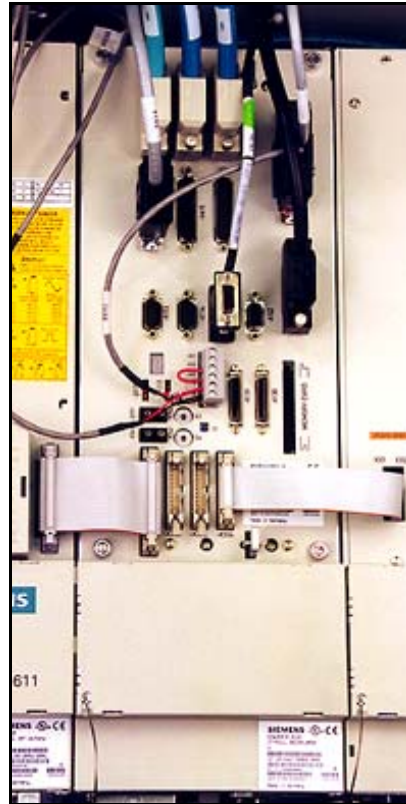

2. Insert the CCU1 (ELE-1089) unit into the CCU box (ELE-1088) and tighten the four screws.

2.1.4 Power Module Replacement

Parts Numbers:

ELE-1090 Power Section

ELE-1091 Accessory Expansion Module

Tools Required:

Torx driver set

NOTE: To remove components for repair or replacement: Follow the assembly instructions as necessary, in reverse order, until the component has been disassembled to required level to conduct the repair.

1. Attach the Power Section Module (ELE-1090) to the mounting bars with four 1/4-20 x 3/4" torx screws. Locate to the immediate right of the CCU Module.

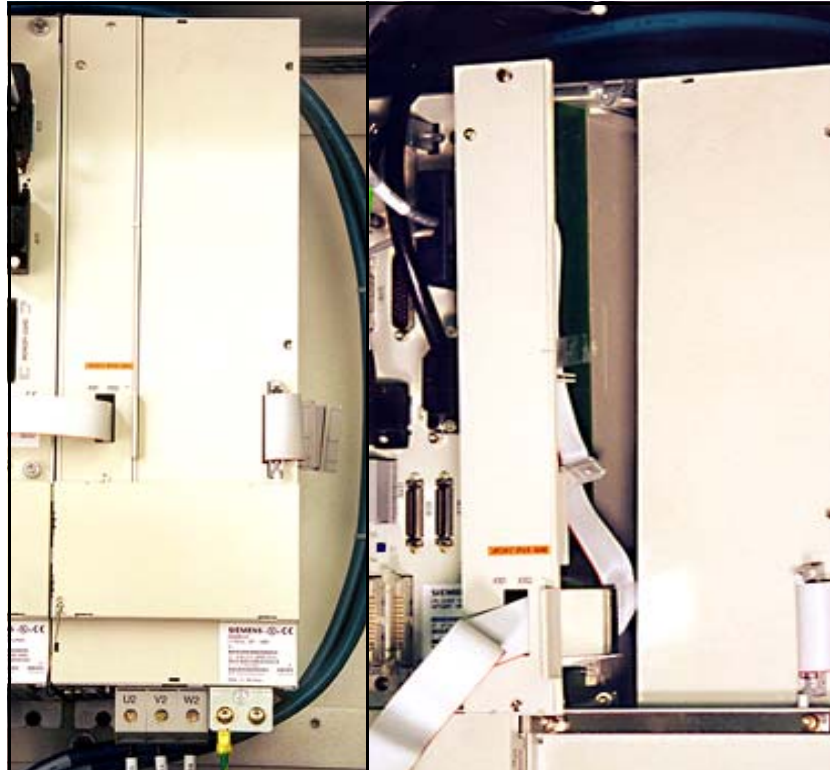

2. Insert the Accessory Expansion Module 810D (ELE-1091) in the Power Section.

2.1.5 Connecting Modules

Tools Required:

Torx Screwdriver

1. Plug the Device Bus Interface X151 Ribbon Cable from the CCU1 unit into the Simodrive X351 Device Bus Port.

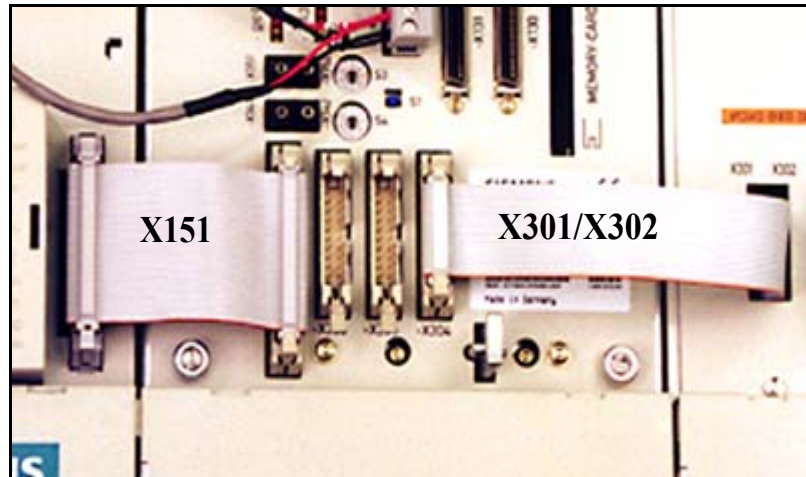

2. Plug the Axis Extension Ribbon Cable (X301/X302) from the Accessory Expansion Module into the X304 Port on the Simodrive Module.

IMPORTANT

Leave the intermodule DC bus link bars disconnected at this time until power-on procedure.

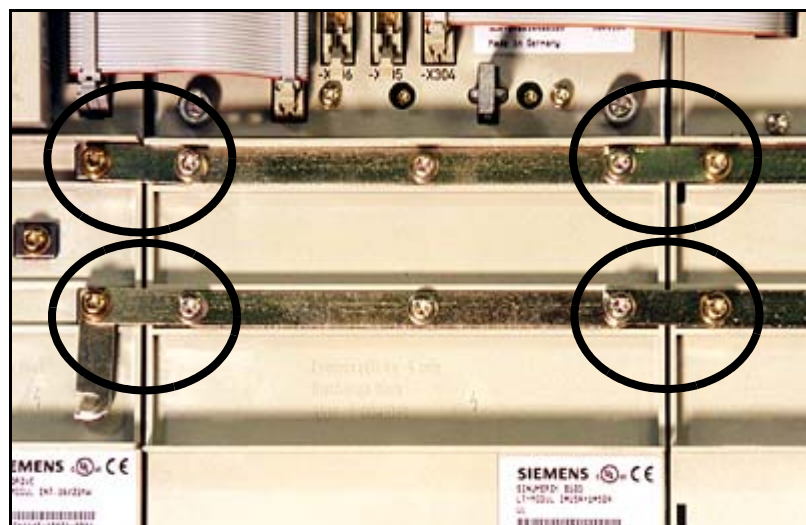

2.2 Wiring Connections

Tools Required:

Torx driver set
Phillips screwdriver
Flat tip screwdriver
Nut driver set

NOTE: To remove components for repair or replacement: Follow the assembly instructions as necessary, in reverse order, until the component has been disassembled to required level to conduct the repair.

2.2.1 CCU1 Module Connections

1. Attach the 37 Pin D-shell line (black) from the MPG into the X121 connection. Secure with thumbscrews. Attach jumper wire (grey) to the X431 terminal block. Red wire to position B, black wire to position 19.
2. Attach the Y-axis signal cable (blue) to the X413 connection. Secure with thumb screws.
3. Attach the X-axis signal cable (blue) to the X412 connection. Secure with thumb screws.
4. Attach the Z-axis signal cable (blue) to the X411 connection. Secure with thumb screws.
5. Attach the spindle encoder cable (grey) to the X414 connection. Secure with thumb screws.
6. Attach the I/O module cable (WIR-0740 black) to the X111 connection. Secure with thumb screws.

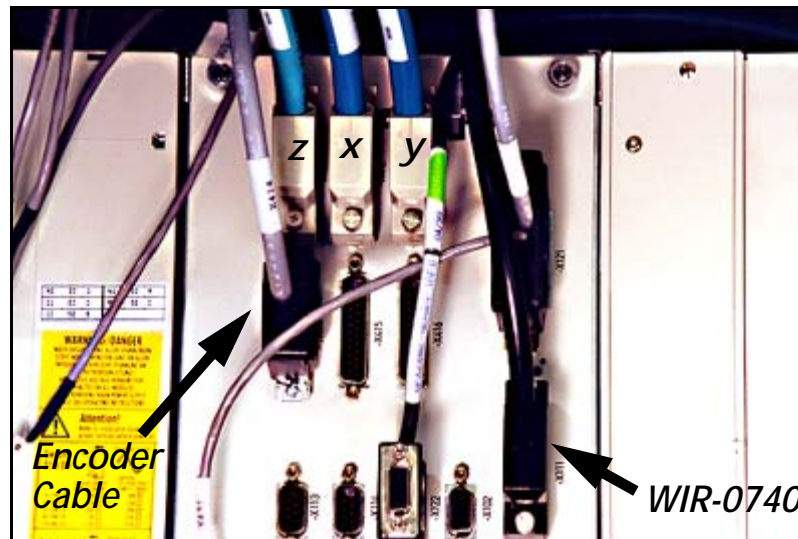

- Attach the spindle orientation magnet out cable (grey) to the X431 terminal block Red to location B Black to location 19. Secure with lug screws.

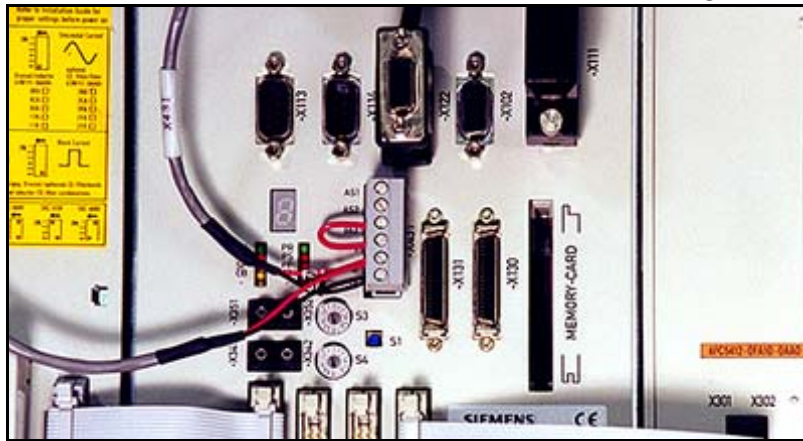

- Plug Z axis motor power connection into terminal plug A1 located on the bottom of the CCU Box. Secure with thumbscrews. Cable clamp cable to shielding plate.

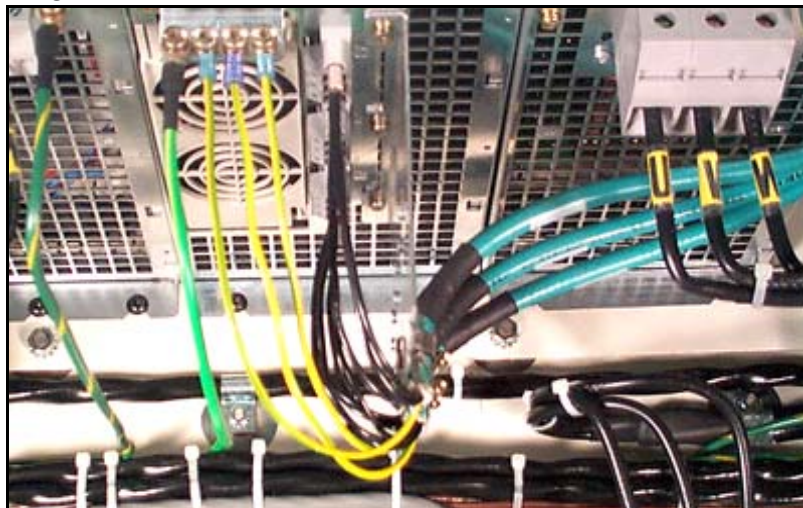

- Attach the Z motor grounding wire to ground plate with existing screw.

10. Plug X-axis motor power connection into terminal plug A2 located on the bottom of the CCU Box. Secure with thumbscrews. Cable clamp cable to shielding Plate.
11. Attach the X motor grounding wire to ground plate with existing screw.
12. Plug Y-axis motor power connection into terminal plug A3 located on the bottom of the CCU Box. Secure with thumbscrews. Cable clamp cable to shielding Plate.
13. Attach the Y motor grounding wire to ground plate with existing screw.
14. Attach grounding wire from the ground bar to the CCU Box.

2.2.2 Simodrive 611 Module Connections

1. Attach the E-stop signal wires to X121 terminal, Red to #64 and Blk/Shd to #19. Secure with lug screws.
2. Attach the E-stop MCP to X121, Red to #9, Blk to #64.
3. Terminate the jumper at #63 and #9.
4. Attach contactor control signal wires to X161 terminal. Secure with lug screws.



5. Attach the power input wires U1, V1, W1 to the appropriately labeled terminals on the bottom of the E/R module. Secure with lug screws.
6. Attach the grounding wire from the ground bar to the grounding terminal on the bottom of the E/R module.

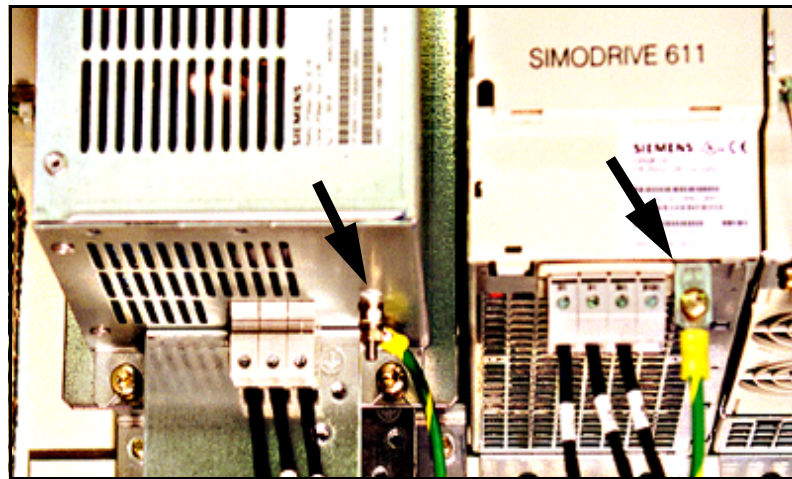

2.2.3 Reactor/Line Filter Module Connections

1. Attach the 380 Volt input wires L1, L2, L3 to the appropriately labeled terminals on the bottom of the Line Filter, secure with lug screws.



2. Attach the Reactor output wires U1, V1, W1 to the appropriately labeled terminals on the bottom of the module, secure with lug screws.

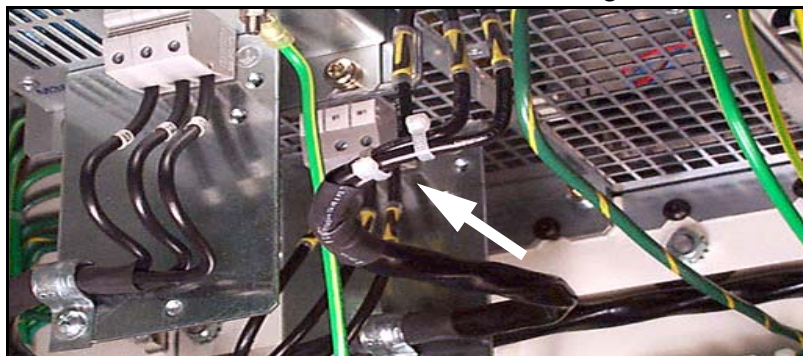

3. Attach the grounding wire from the ground bar to the bottom of the line filter module with a 1/4-20 nut and washer.

- Attach the grounding wire from the ground bar to the reactor module.

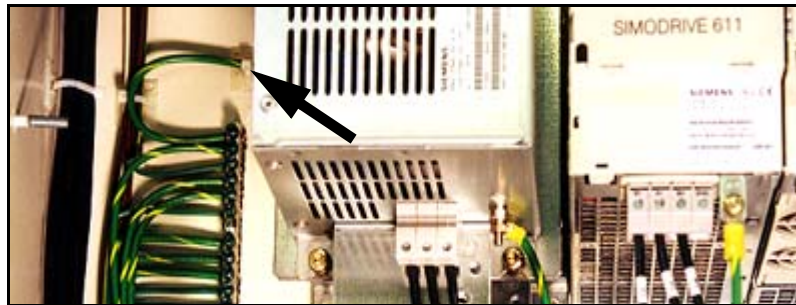

2.2.4 Power Module Connections

- Attach the spindle drive output wires U2, V2, W2 to the appropriately labeled terminals on the bottom of the power module, secure with lug screws.

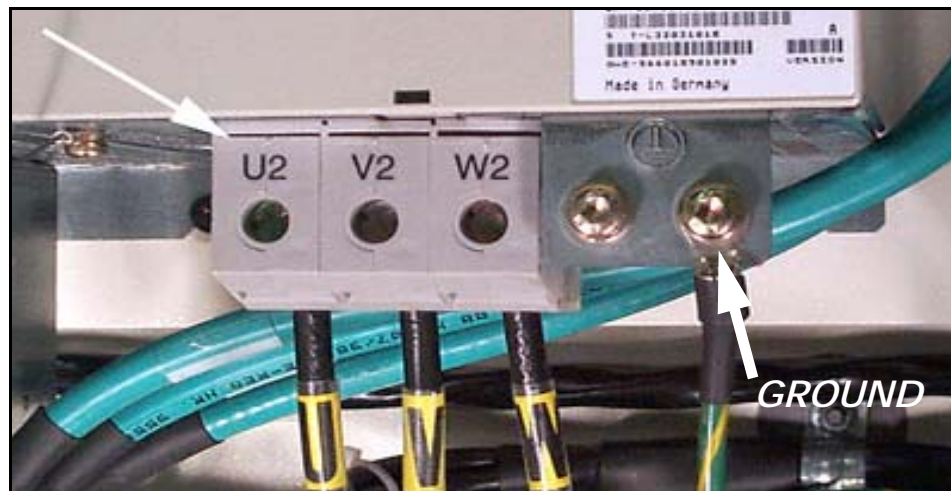

- Attach the grounding wire from the ground bar to the bottom of the power module, secure with lug screw.

2.3 Replacing the 24V Power Supply

Parts Numbers:

ELE-1095 24 Volt Power Supply

Tools required:

Screwdriver

NOTE: To remove components for repair or replacement: Follow the assembly instructions as necessary, in reverse order, until the component has been disassembled to required level to conduct the repair.

- Snap power supply onto the rail.

2. Attach the 120 VAC input wires to the 24 VDC power supply.

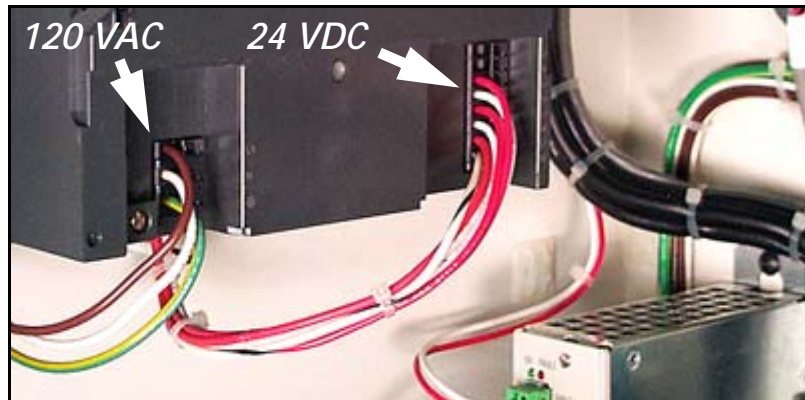

3. Attach the 24 VDC output wires to the power supply.

2.4 Replacing the I/O Module

Parts Numbers:

ELE-1093 I/O Module

Tools required:

Phillips screwdriver

NOTE: To remove components for repair or replacement: Follow the assembly instructions as necessary, in reverse order, until the component has been disassembled to required level to conduct the repair.

1. Attach I/O module (ELE-1093) to the lower left corner of cabinet with two 1/4-20 x 3/4" screws.



2. Connect the X404 cable from the 2010-0 interface board to the X404 plug on the I/O module.
3. Connect the X405 cable from the 2010-0 interface board to the X405 plug on the I/O module.
4. Connect the X402 cable from the 2010-0 interface board to the X402 plug on the I/O module.

5. Connect WIR-0740 from the CCU1 module to the X3IN plug on the I/O module. Secure with thumb screws.

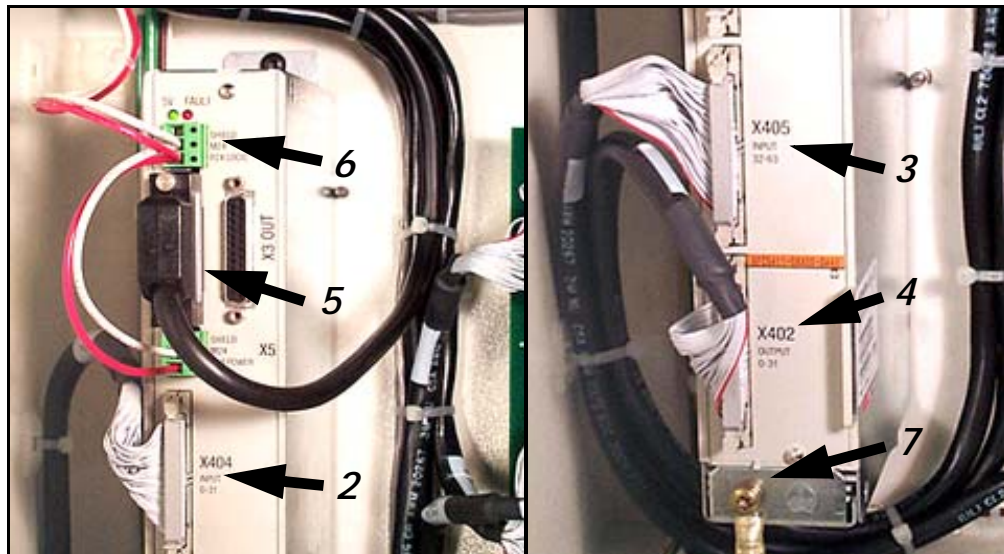

6. Connect the 24 volt power supply wiring to X1 (Ground to M24, + 24 VDC to P24 logic, shield no connection) and connect jumper to X5 (Ground to M24, + 24 VDC to P24 logic, shield not connected).

7. Connect the ground wire to the chassis.

2.5 Replacing the 2010-0 Board

Parts Numbers:

PCB-0205 2010-0 Interface Board
PCB-0045 Temperature Control Card

Tools Required:

Assorted Screwdrivers

1. Attach 2010-0 board (PCB-0205) to the back of the cabinet with hardware (HDW-0509, HDW-0460, HDW-0453).

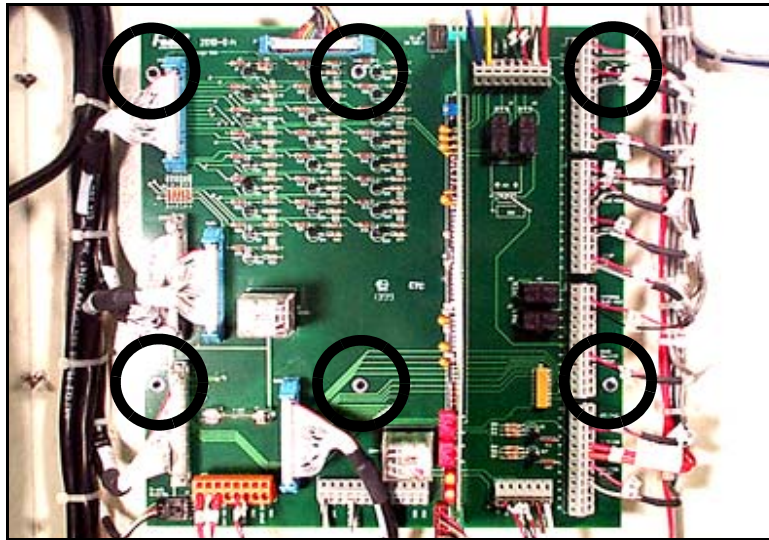

2. Connect the X402 cable to the X402 plug on the 2010-0 card.

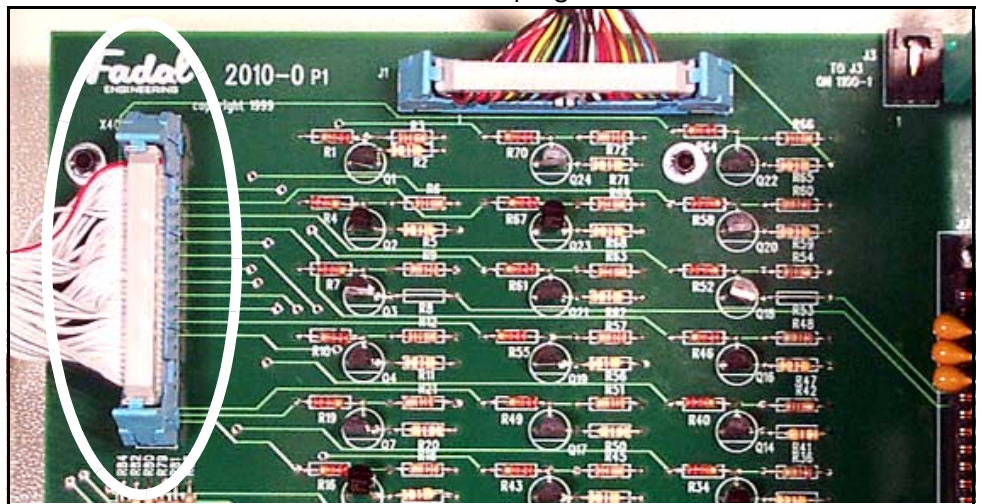

3. Connect the X1201 cable to the X1201 plug on the 2010-0 card.

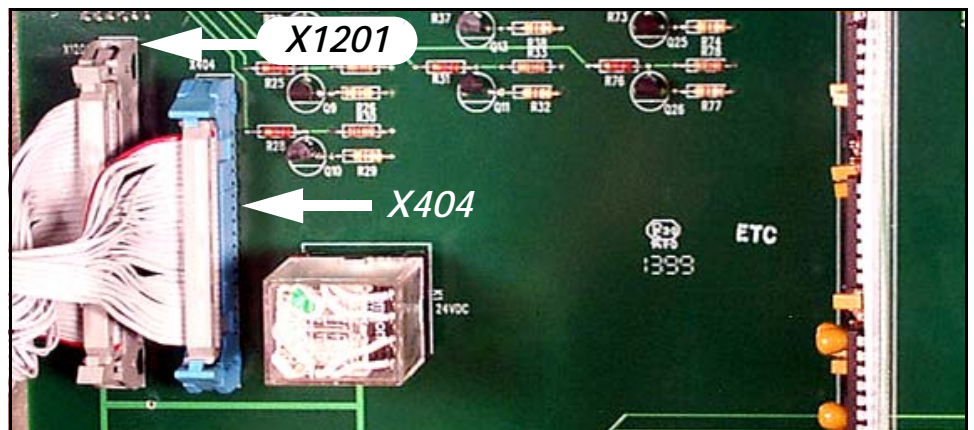

4. Connect the X404 cable to the X404 plug on the 2010-0 board.

5. Connect the X1202 cable to the X1202 plug on the 2010-0 board.

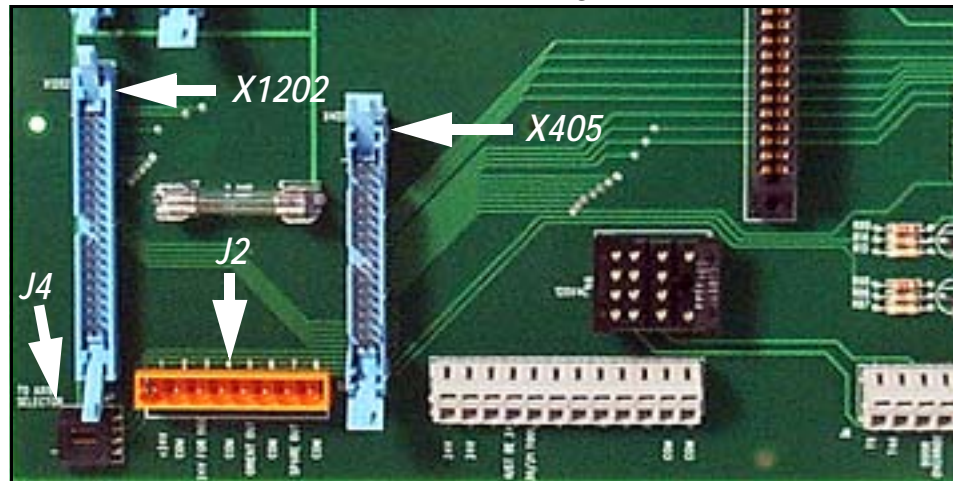

6. Connect the X405 cable to the X405 plug on the 2010-0 board.
7. Connect the Axis Selector wire two pin plug into the J4 socket on the 2010-0 board.
8. Connect the J2 wire plug into the J2 eight position wire connector on the 2010-0 board.
9. Terminate contactor control wires T9 (red) and T48 (blk) at appropriate location on terminal strip J6.

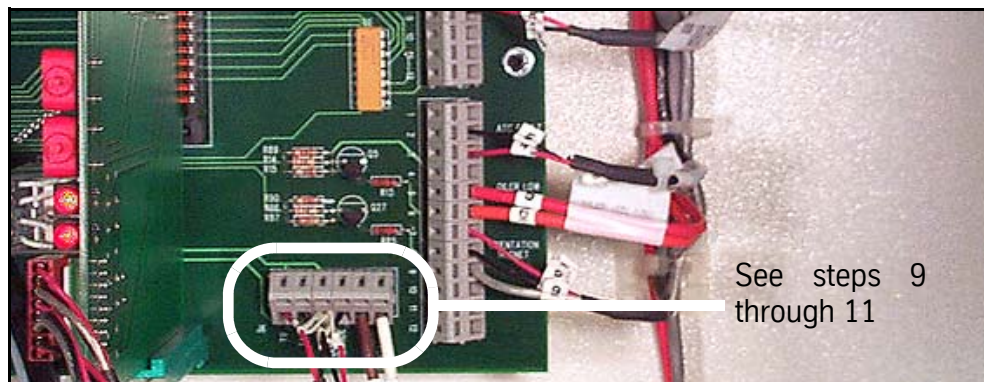

10. Terminate door override wires #3 (red) and #4 (blk) at appropriate location on terminal strip J6.
11. Terminate spindle contactor wires #5 (brn) and #6 (wht) at appropriate location on terminal strip J6.
12. Terminate control bus wires to appropriate location on right side terminal strip.

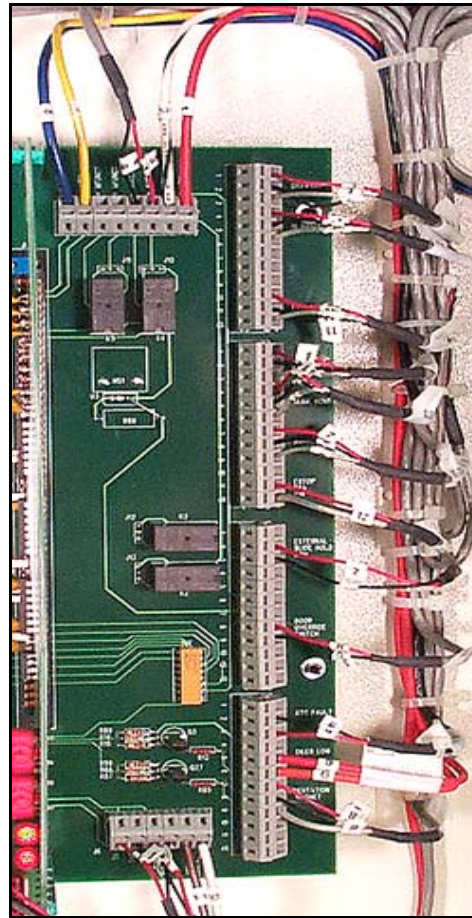

13. Terminate J5 bus wires at appropriate location on J5 terminal.

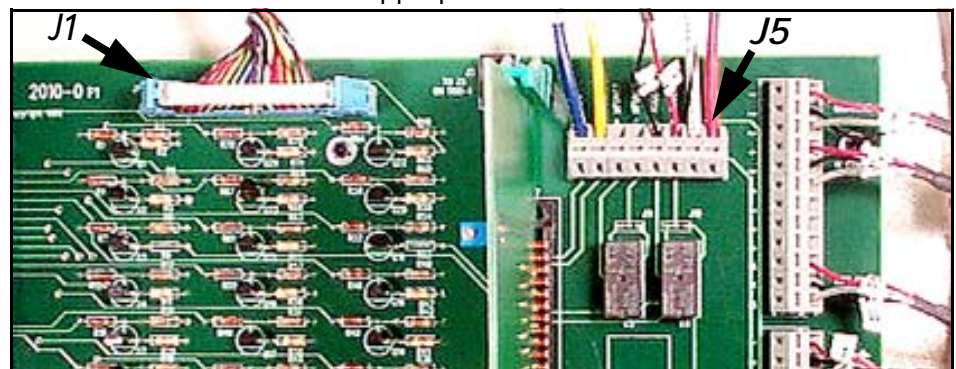

14. Connect the J1 cable from the 1100-1 board into the J1 plug on the 2010-0 board.

15. Plug the temperature control board into the J7 socket on the 2010-0 board.

16. Connect the temperature control wire plug into the socket on the temperature control board.

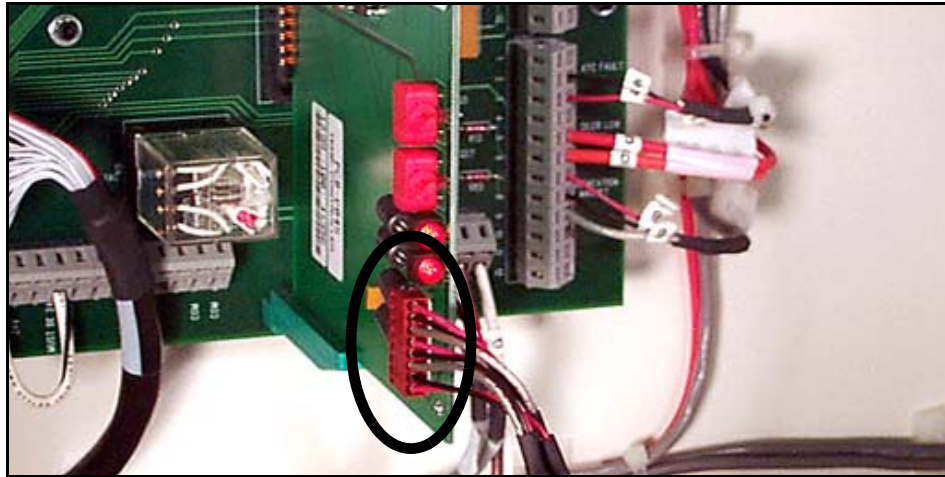

17. Plug the K1 relay into the 24 VDC K1 receptacle on the 2010-0 board.
18. Plug the K6 relay into the 120 VAC K6 receptacle on the 2010-0 board.

2.6 Replacing Fadal 5 VDC Power Supply

Parts Numbers:

ELE-1139 5 volt and 12 volt power supply

Tools Required:

Screwdriver
Nut Driver

NOTE: To remove components for repair or replacement: Follow the assembly instructions as necessary, in reverse order, until the component has been disassembled to required level to conduct the repair.

1. Attach power supply (ELE-1139) to cabinet with three 10/32 nuts (HDW-0339).



2. Terminate 5 volt, +12 VDC, and -12 VDC wires at power supply.

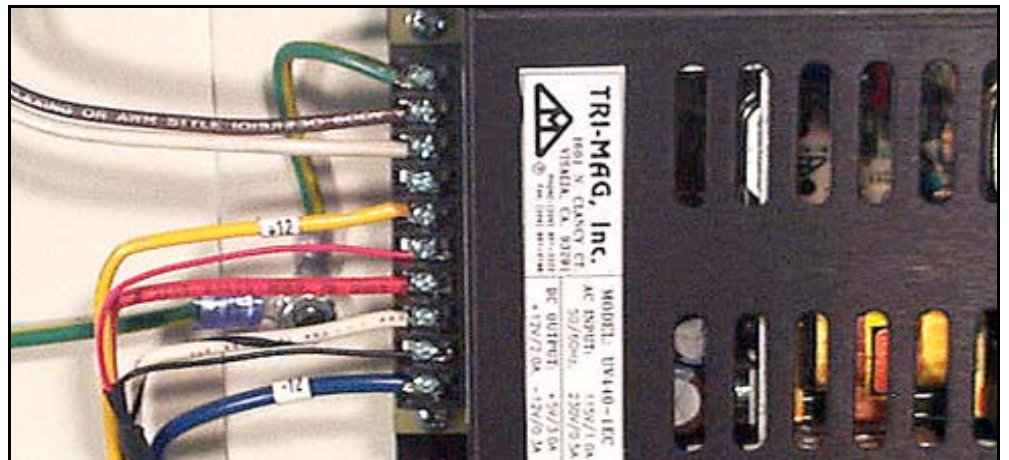

2.7 Replacing Pendant Components

NOTE: To remove components for repair or replacement: Follow the assembly instructions as necessary, in reverse order, until the component has been disassembled to required level to conduct the repair.

2.7.1 2020 Power Distribution Board

1. Install 2020 power distribution board (PCB-0204) with four nylock nuts (HDW-0657).

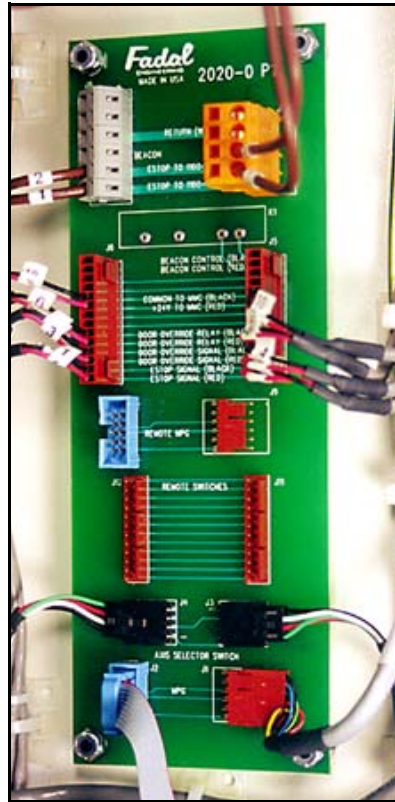

2. Terminate all connections on the 2020 power distribution board as shown.

2.7.2 MPG Panel

- Install lower left MPG panel (STM-0872).



2.7.3 MCU Panel

Install machine control panel (CTR-0127).



2.7.4 PCU 210

Install PCU 210 Op panel (CTR-0126).

2.7.5 Keyboard

Install keyboard (ELE-1094)



2.7.6 Wiring Connections

Terminate all wiring and check for proper connections.

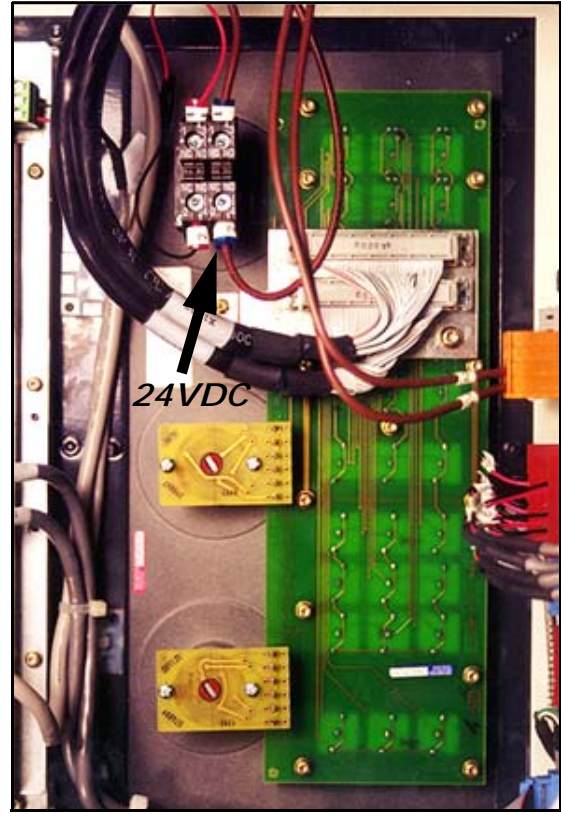
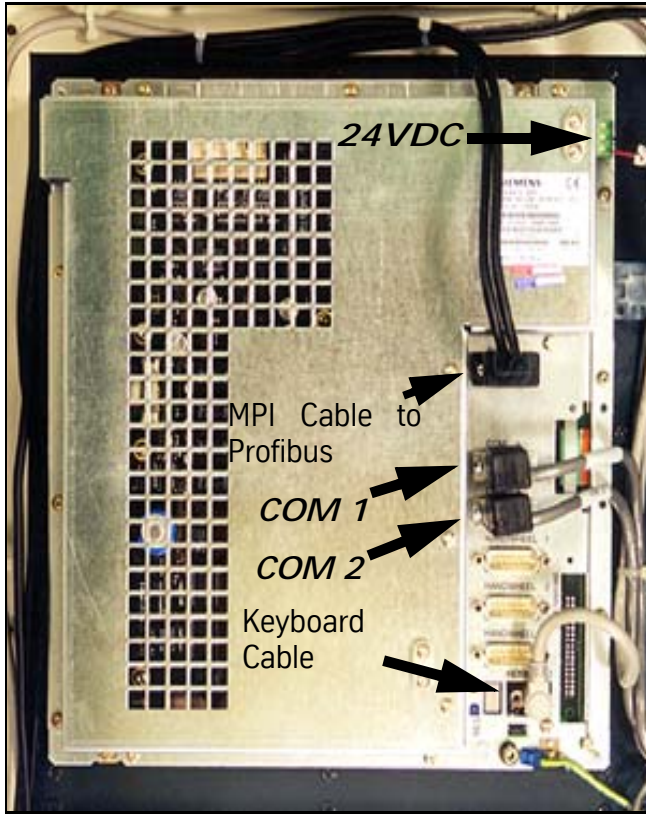

Section 03: Power On Procedure

Alarms

The Siemens control has an extensive alarm code series. The alarms most likely to occur while performing power on and assembly procedures for the machine are listed. For a complete listing of all alarms refer to the Siemens diagnostics manual.

1000 Series Alarms

The 1000 series alarms are an indication of a serious problem with the Siemens controller.

Overview of the system error alarms

The following alarms are system errors:

1000 1005 1013 1017
1001 1010 1014 1018
1002 1011 1015 1019
1003 1012 1016 1160

These system error alarms are not described in detail. If such a system error occurs, please contact your dealer or Fadal Machining Centers *indicating the alarm number, the alarm text and the appropriate internal system error number.*

2000 Series Alarms

2001 PLC has not started up

Explanation: The PLC must give at least one sign of life within the time defined in the MD 10120 **PLC_RUNNINGUP_TIMEOUT** (default setting: 1 sec.). There is a serious problem with the PLC program.

Reaction:

NC Start disable.
NC not ready.
Mode group not ready.
NC Stop when alarm.
Alarm display.
Interface signals are set.

Remedy: The monitoring time in MD 10120 **PLC_RUNNINGUP_TIMEOUT** must be checked and adapted to the first OB1 cycle.

Establish the cause of error in the PLC (loop or stop in the user program) and eliminate.

Program Continuation: Switch control OFF - ON.

2100 NCK battery warning threshold reached

Explanation: The undervoltage monitoring of the NCK battery has reached the prewarning threshold. This is at 2.7-2.9 V (nominal voltage of the battery is 3.0 - 3.1 V at 950 mAh).

Reaction: Alarm display.

Remedy: The battery must be replaced within the next 6 weeks. After this period, the voltage can drop below the alarm limit of 2.4 - 2.6 V if the RAMs to be buffered take up a lot of current.

Program Continuation: Clear the alarm with the Delete key. No further operator action necessary.

2101 NCK battery alarm

Explanation: The undervoltage monitoring (2.4 - 2.6 V) of the NCK battery has responded **during cyclic operation**.

Reaction: Alarm display.

Remedy: If the NCK battery is replaced without interrupting the power supply, no data will be lost. This means that production can continue without taking any further steps. (A buffer capacitor on the NCK holds the supply voltage for at least 30 minutes and the battery can be replaced within this time even when the control is switched off).

Program Continuation: Clear the alarm with the Delete key. No further operator action necessary.

2102 NCK battery alarm

Explanation: The undervoltage monitoring (2.4 - 2.6 V) of the NCK battery was detected **during system power-up**.

Reaction:

Alarm display.

Interface signals are set.

NC not ready.

Mode group not ready.

NC Start disable.

NC Stop when alarm.

The NC switches to follow-up mode.

Remedy: Pull out the battery/fan unit from the NC module and replace the battery (type: lithium battery with lead, size 1/2 AA, 850 mAh, min. 3.2 V).

The system must then be reinitialized because it must be assumed that data has been lost in the buffered RAM during the last power-off phase as a result of insufficient supply voltage (refer to section in the Installation and Start-up Guide for the procedure).

The following data might have been corrupted or entirely lost:

- NC machine data
- Drive machine data
- Operator panel machine data
- Option data
- Setting data
- User variable
- Global subroutines
- Cycles and macros, as well as
- PLC machine data
- PLC basic program
- PLC user program, and all
- PLC user data

User data in the NCK and PLC that had been altered since the last data save by the ongoing manufacturing process (e.g. tool and workpiece data) must be adapted manually to the momentary machine state.

Program Continuation: Switch control OFF - ON.

2110 NCK temperature alarm

Explanation: The temperature sensor has reached the response threshold of $60^{\circ}\text{C} \pm 2.5^{\circ}\text{C}$.

Reaction: Alarm display.

Remedy: For switching back the sensor, a temperature reduction of 7°C is necessary.

Program Continuation: Clear the alarm with the Delete key. No further operator action necessary.

2120 NCK fan alarm

Explanation: The fan consists of a 26 V DC motor with electronic commutator (rated speed: approx. 8700 rpm). The commutator signal is used for speed monitoring, response speed: <7500 rpm.

Reaction: Alarm display.

Remedy: The unit with the fan must be replaced.

Program Continuation: Clear alarm with the RESET key. Restart part program.

2130 NCK encoder power supply (%1 V) has failed

Explanation: %1 = Voltage
The power supply (5V / 24V) for the encoders has failed.

Reaction:
Mode group not ready.
Channel not ready.
NC Start disable.
NC Stop when alarm.
The NC switches to follow-up mode.
Alarm display.
Interface signals are set.

The axes are no longer synchronized with machine actual value (reference point is lost).

Remedy: Check encoders and cables for short circulating (disconnect cables, then this error should be cleared). Eliminate any defect.

Program Continuation: Switch control OFF - ON.

2140 The actual service switch position forces a SRAM to be cleared at the next Power On (general reset active)

Explanation: The initialization switch is currently set to overall reset. This means that the module's SRAM is deleted at the next module reset. The NC data memory is cleared during this operation.

Reaction:
Alarm display
Interface signals are set
NC not ready.

Remedy: Reset initialization switch to one

Program Continuation: Alarm display disappears with cause of alarm. No further operator action necessary.

3000 Series Alarm

3000 Emergency Stop

Explanation: The EMERGENCY STOP request is applied to the NCK/PLC interface (DB 10, DBX 56.1).

Reaction:

NC Start disable.
NC not ready
All mode groups not ready.
NC Stop when alarm.
Alarm display.
Interface signals are set.

Remedy: Rectify the cause of EMERGENCY STOP and acknowledge EMERGENCY STOP via the PLC/NCK interface (DB 10, DBX 56, bit 2).

Program Continuation: Press the Reset key to clear alarm in all channels of this mode group. Make sure that the E-stop is not pressed.

3001 Internal emergency stop

Explanation: This alarm is not displayed.

Reaction:
NC Start disable.
NC not ready.
All mode groups not ready.
NC Stop when alarm.
NC reacts within a machining station.

Remedy: No remedy required

Program Continuation: Press the Reset key to clear alarm in all channels of this mode group.

4000 Series Alarm

4000 Channel %1 machine data %2 has gap in axis assignment

Explanation:

%1 = Channel number

%2 = String: Machine data identifier

The assignment of a machine axis to a channel by the machine data 20070 **AXCONF_MACHAX_USED** must be contiguous. At system power-up (Power On) gaps are detected and displayed as an alarm.

Reaction:
Alarm display.
Interface signals are set.
Mode group not ready.
Channel not ready
NC Start disable.
NC Stop when alarm.

Remedy: Configure channel-specific machine data 20070 **AXCONF_MACHAX_USED** for the axis assignment without gaps, that is, with increasing channel axis indices a machine axis must continue to be assigned until a zero is entered for the first time (not a machine axis). All MD higher indices must then also contain a 0.

The sequence of the machine axis numbers is irrelevant!

Channel axis index	1st channel	2nd channel	Machine axis number
0	1	4	AXCONF_MACHAX_USED [CH1, AX1] = 1
1	2	5	AXCONF_MACHAX_USED [CH1, AX2] = 2
2	3	6	AXCONF_MACHAX_USED [CH1, AX3] = 3
3	7	0	AXCONF_MACHAX_USED [CH1, AX4] = 7
4	8	0	AXCONF_MACHAX_USED [CH1, AX5] = 8
5	0	0	AXCONF_MACHAX_USED [CH2, AX1] = 4
6	0	0	AXCONF_MACHAX_USED [CH2, AX2] = 5
7	0	0	AXCONF_MACHAX_USED [CH2, AX3] = 6

Assignment of channel axes to machine axes

Program Continuation: Switch control OFF - ON.

4001 Channel %1 axis %2 defined for more than one channel via machine data %3

Explanation:

%1 = Channel number

%2 = Index: Machine axis number

%3 = String: Machine data identifier

In the channel-specific MD: 20070 **AXCONF_MACHAX_USED [CHn, AXm]=x** (n... channel number, m... channel axis number, x... machine axis number) several channels have been assigned to one machine axis without having defined a master channel for this axis.

There is usually not much point in assigning a machine axis to several channels. In exceptional cases, multiple assignment can be performed if a master channel is defined for this axis. The channel assignment can be performed in accordance with the machining requirements in the NC part program by means of a keyword (yet to be defined in later product versions).

Reaction:

Alarm display.

Interface signals are set.

Mode group not ready.

Channel not ready.
NC Start disable.
NC Stop when alarm.

Remedy: In the axis-specific MD 30550 **AXCONF_ASSIGN_MASTER_CHAN [AXm]=n** (m... machine axis number, n... channel number) a master channel must be specified for the axes that are assigned by the NC program alternately for one channel or the other.

Program Continuation: Switch control OFF - ON.

4002 Channel %1 machine data %2[%3] assigns an axis not defined in channel

Explanation:

- %1 = Channel number
- %2 = String: Machine data identifier
- %3 = Index: Machine data array index

Only axes that have been activated in the channel by means of the channel-specific machine data 20 070 **AXCONF_MACHAX_USED [k x]=m** may be declared as geometry axes by means of the MD 20050 **AXCONF_GEOAX_ASSIGN_TAB [g x]=k**.

g x... Geometry axis index k... Channel axis no.
k x... Channel axis index m... Machine axis no. Program continuation

AXCONF_GEOAX_ASSIGN_TAB (includes channel axis no. k)			AXCONF_MACHAX_USED (includes channel axis no. m)		
Geometry axis index	1st channel	2nd channel	Channel axis index	1st channel	2nd channel
0	1	1	0	1	4
1	2	0	1	2	5
2	3	3	2	3	6
			3	7	0
			4	8	0
			5	0	0
			6	0	0
			7	0	0

Assignment of geometry axes to channel axes

Reaction:
Alarm display.
Interface signals are set.
Mode group not ready.

Channel not ready.
NC Start disable.
NC Stop when alarm.

Remedy: Check and correct machine data 20050 **AXCONF_GEOAX_ASSIGN_TAB** and 20 070 **AXCONF_MACHAX_USED**.

The basis is the MD array **AXCONF_MACHAX_USED** in which the machine axis number is entered that is to be controlled from a specific channel. The resulting "Channel axes" are given a name by the MD **AXCONF_CHANAX_NAME_TAB** and assigned to a geometry axis by the MD **AXCONF_GEOAX_ASSIGN_TAB**; the corresponding channel axis is entered for each geometry axis in this MD.

Program Continuation: Switch control OFF - ON.

4003 Axis %1 assignment of master channel in machine data %2 incorrect or missing

Explanation:

%1 = Axis

%2 = String: Machine data identifier

For some applications, it is useful to operate an axis in several channels (C axis or spindle on single spindle or double carriage machines).

The machine axes which are defined in several channels by means of the MD 20 070 **AXCONF_MACHAX_USED**, must be assigned to a master channel with the axis-specific machine data 30 550 **AXCONF_ASSIGN_MASTER_CHAN**.

For axes that are activated in only one channel, the number of this channel or zero must be entered as master channel.

Reaction:

Alarm display.
Interface signals are set.
NC not ready.
Mode group not ready.
NC Start disable.
NC Stop when alarm.

Remedy: Correct MD 20 070: **AXCONF_MACHAX_USED** and/or MD 30 550: **AXCONF_ASSIGN_MASTER_CHAN**.

Program Continuation: Switch control OFF - ON.

4060 Standard machine data loaded

Explanation: With the next system power-up, the standard MDs are loaded by the system-specific MD 11 200 **INIT_MD** if

- **MD buffer voltage has failed** or
- After an **initialization** for loading the standard machine data.

Reaction: Alarm display.

Remedy: After automatically loading the standard MDs, the individual MDs must be entered or loaded in the relevant system.

Program Continuation: Clear alarm with the RESET key. Restart part program.

4062 Backup data loaded

Explanation: The user data saved in the flash memory are loaded to the SRAM.

Reaction: Alarm display.

Remedy: Load specific machine data again

Program Continuation: Clear alarm with the RESET key.

4075 Machine data %1 (and maybe others) not altered - permission level %2 needed

Explanation:

%1 = String: MD identifier

%2 = Write protection level of the MD

On executing a TOA file or when writing data from the part program, an attempt has been made to write an item of data with a higher protection level than the access authorization currently set in the control. The item of data in question has not been written and program execution is continued. This alarm is set only when access violation is detected for the first time.

Reaction: Alarm display.

Remedy: Set the required access level by means of password entry or delete the machine data concerned from the MD file / part program.

Program Continuation: Clear the alarm with the Delete key. No further operator action necessary.

4076 %1 Machine data could not be altered with permission level %2

Explanation:

%1 = Number of MDs

%2 = Preset access authorization

On executing a TOA file or when writing data from the part program an attempt has been made to write data with a higher protection level than the access authorization currently set in the control. The data in question have not been written and program execution is continued without hindrance. This alarm is issued on acknowledging the alarm EXBSAL_MD_PERMISSION_DENIED. It can be cleared only with Power On.

Reaction: Alarm display.

Remedy: Set the required access level by means of password entry or delete the machine data concerned from the MD file / part program.

Program Continuation: Switch control OFF - ON

Note: The following two alarms indicate problems requiring a service call by a trained technician.

4290 Sign-of-life monitoring: local P-bus not alive

Explanation: The COM computer must alter the sign-of-life on the local P-bus in each SERVO cycle. Monitoring for alteration takes place in the IPO cycle. If the sign of life has not altered, this alarm is triggered.

Reaction:

Alarm display.
Interface signals are set.
NC not ready.
Mode group not ready.
NC Start disable.
NC Stop when alarm.

Remedy: Check hardware

Program Continuation: Switch control OFF - ON.

4291 Failure of module in local P-bus slot %1, error codes %2 %3 %4

Explanation:
%1 = Slot number
%2 = Error code
%3 = Error code
%4 = Error code

The module on the specified slot has signaled a diagnostics alarm. The error code reported corresponds to the AS300 documentation

Reaction:

Alarm display.
Interface signals are set.
NC not ready.

Mode group not ready.
NC Start disable.
NC Stop when alarm.

Remedy: Check hardware

Program Continuation: Switch control OFF - ON.

6000 Series Alarm

6020 Machine data have been altered - now memory is reorganized

Explanation: Machine data have been changed that define the NC user memory allocation. Data management has restructured the memory in accordance with the altered machine data.

Reaction: Alarm display.

Remedy: No remedial measures are required. Any user data that are required must be input again.

Program Continuation: Clear alarm with the RESET key. Restart part program.

6500 NC memory is full

Explanation: The file system (part of the NC memory) of the NC is full. The job cannot be executed, e.g. too many part programs loaded.

Note: During initial start-up, this can concern files from the NC file system, e.g. drive data, MMC files, FIFO files, NC programs, ...

Reaction: Alarm display.

Remedy: Delete or unload files (e.g. part programs).

Program Continuation: Clear the alarm with the Delete key. No further operator action necessary.

6510 Too many files in the NC memory

Explanation: The number of files in the file system (part of the NC memory) of the NC has reached the maximum number possible

Note: During initial start-up, this can concern files from the NC file system, e.g. drive data, MMC files, FIFO files, NC programs, ...

Reaction: Alarm display.

Remedy:

- Delete or unload files (e.g. part programs), or
- Increase \$MM_NUM_FILES_IN_FILESYSTEM

Program Continuation: Clear the alarm with the Delete key. No further operator action necessary.

6520 Too many protocol files in the NC memory

Explanation: The number of files in the file system (part of the NC memory) of the NC has reached the maximum limit.

Reaction: Alarm display.

Remedy: Run fewer log activities in the NC at the same time.

Program Continuation: Clear the alarm with the Delete key. No further operator action necessary.

6530 Too many files in directory

Explanation: The number of files in one directory of the NCK has reached the maximum limit

Reaction: Alarm display.

Remedy:

- Delete or unload files (e.g. part programs) in the respective directory, or
- Increase \$MM_NUM_FILES_PER_DIR

Program Continuation: Clear the alarm with the Delete key. No further operator action necessary.

6540 Too many directories in the NC memory

Explanation: The number of directories in the file system of the NCK has reached the maximum limit

Reaction: Alarm display.

Remedy:

- Delete or unload directory (e.g. workpiece), or
- Increase \$MM_NUM_DIR_IN_FILESYSTEM

Program Continuation: Clear the alarm with the Delete Key. No further operator action is necessary.

6550 Too many subdirectories

Explanation: The number of subdirectories in a directory of the NCK has reached the maximum limit

Reaction: Alarm display.

Remedy:

- Delete or empty subdirectories in the respective directory, or
- Increase \$MM_NUM_SUBDIR_PER_DIR

Program Continuation: Clear the alarm with the Delete key. No further operator action necessary.

6560 Data format not allowed

Explanation: An attempt was made to write impermissible data in an NCK file. This error can occur in particular when the attempt was made to load binary data in the NCK as ASCII file.

Reaction: Alarm display.

Remedy: Specify that the file concerned is a binary file (e.g. extension:.BIN)

Program Continuation: Clear the alarm with the Delete key. No further operator action necessary.

8000 Series Alarm

8030 Channel %1 block %2 option 'interpolation of more than 4 axes' not set

Explanation:

%1 = Channel number

%2 = Block number, label

The option for the number of interpolating axes does not correspond to the number of axes programmed in the interpolation group.

Reaction:

Alarm display.

Interface signals are set.

NC Start disable.

Interpreter Stop.

Remedy: Option: Retrofit "Interpolation of more than 4 axes" (the number of axes that is then allowed can be set in this option) or specify in the part program as many (or fewer, as required) axes corresponding to the configuration of the control.

Program Continuation: Clear alarm with the RESET key. Restart part program.

10000 Series Alarm

10203 Channel %1 NC Start not possible with unreferenced axes (action =%2)

Explanation: %1 = Channel number

NC Start has been activated in the MDA or AUTOMATIC mode and at least one axis that needs to be referenced or has not reached its reference point.

Reaction: Alarm display.

Remedy: Via the channel-specific **MD 20700: REFP_NC_START_LOCK** (NC Start without reference point) you can decide whether the axis must be referenced before NC Start or not. The start of referencing can be enabled channel-specific or axis-specific. *On the FADAL 3020 all axes must be referenced before switching to AUTO or MDA.*

1. Channel-specific reference point approach: The rising edge of the interface signal "activate referencing" (DB 21 - 28, DBX 1.0) starts an automatic sequence which starts the axes of the channel in the same sequence as specified in the axis-specific MD: 34110 **REFP_CYCLE_NR** (axis sequence channel-specific referencing).

-1: The axis does not participate in channel-specific referencing, but it must be referenced for NC Start

0: The axis does not participate in channel-specific referencing, but it need not be referenced for NC Start

1- 8: Start sequence for channel-specific referencing (simultaneous start with identical no.)

2. Axis-specific referencing: Press the direction key that corresponds to the approach direction in the axis-specific MD: 34010 **REFP_CAM_MDIR_IS_MINUS** (reference point approach in minus direction).

Program Continuation: Clear alarm with NC START and continue processing.

10208 Channel %1 Continue program with NC Start

Explanation: %1 = Channel number

After block search with calculation, the control is in the desired state. The program can now be started with NC Start or the state can be changed for the time being with overstore/jog. M01 present and active in part program.

Reaction:

Alarm display.
NC Stop when alarm.

Remedy: Press NC Start

Program Continuation: Clear alarm with NC START and continue processing.

10223 Channel %1 command %2 already active

Explanation:

%1 = Channel number
%2 = String

This channel has received a negative acknowledgment from the inter-channel communication because this command is already active or has not yet been terminated. E.g.: INIT(x,"ncprog") but a program select request is already active for channel x.

Reaction: Alarm display.

Remedy: This is an indication of possible discrepancies. The program continues if no acknowledgment is called for.

Program Continuation: Clear alarm with the Cancel key. No further operator action necessary.

10225 Channel %1 command %2 refused

Explanation: %1 = Channel number
The channel has received a command that cannot be executed.

Reaction: Alarm display.

Remedy: Press RESET.

Program Continuation: Clear alarm with the Cancel key. No further operator action necessary.

10249 Mode group %2 channel %1 command change-of-operation-mode aborted

10602 Channel %1 block %2 velocity limitation during thread cutting

Explanation:
%1 = Channel number
%2 = Block number, label

In the displayed thread block, the axis would exceed its maximum velocity when the spindle override is in the maximum position.

Reaction: Alarm display.

Remedy: If the axis velocity is not limited (faultless thread) no remedial measures are necessary. Otherwise, a lower spindle speed must be programmed for the thread block.

Program Continuation: Clear alarm with the Cancel key. No further operator action necessary.

10610 Channel %1 axis %2 not stopped

Explanation:

%1 = Channel number
%2 = Block number, label

An axis/spindle has been positioned over several NC blocks using the POSA/SPOSA instruction. The programmed target position had not yet been reached ("exact stop fine" window) when the axis/spindle was reprogrammed.

Example:

```
N100 POSA[U]=100
:
N125 X... Y... U...; e.g.: U axis still travels from N100!
```

Reaction:

NC Start disable.
NC Stop when alarm.
Alarm display.
Interface signals are set.

Remedy: Check and correct the part program (analyze whether motion beyond block boundaries is at all meaningful here). Prevent block change by means of the keyword WAITP until the positioning axes have also reached their target position.

Example:

```
N100 POSA[U]=100
:
N125 WAITP[U] N130 X... Y... U...
```

Program Continuation: Clear alarm with RESET key. Restart part program.

10620 Channel %1 block %3 axis %2 at software limit switch %4

Explanation:

%1 = Channel number
%2 = Axis name, spindle number
%3 = Block number, label
%4 = String

During the traversing motion, it is recognized that the software limit switch would be overtraveled in the displayed direction. It was not yet possible to detect in the block preparation that the traversing range would be exceeded: either there has been a motion overlay by the **handwheel** or a **coordinate transformation** is active.

Reaction:

Alarm display.
Interface signals are set.
NC Start disable.

Remedy: Depending on the reason for this alarm being triggered, the following remedial measures should be undertaken:

1. **Handwheel override:** Cancel the motion overlay and avoid this or keep it smaller when the program is repeated.
2. **Transformation:** Check the preset/programmed zero offsets (current frame). If the values are correct, the tool holder (fixture) must be moved in order to avoid triggering the same alarm when the program is repeated, which would again cause the program to be aborted.

Program Continuation: Clear alarm with RESET key. Restart part program.

10621 Channel %1 axis %2 rests on software limit switch %3

Explanation:

%1 = Channel number

%2 = Axis name, spindle number

%3 = String

The specified axis is already stationary at the displayed software travel limit.

Reaction: Alarm display.

Remedy: Machine data:

36110 POS_LIMIT_PLUS/36130 POS_LIMIT_PLUS2 and
36100 POS_LIMIT_MINUS/36120 POS_LIMIT_MINUS2
must be checked for the software limit switches.

Axis-specific interface signals: “2nd software limit switch plus” (DB 31 - 48, DBX 12.3) and “2nd software limit switch minus” (DB 31 - 48, DBX 12.2) check whether the 2nd software limit switch is selected.

Program Continuation: Alarm display disappears with cause of alarm. No further operator action necessary.

10630 Channel %1 block %2 axis %3 at working area limit %4

Explanation:

%1 = Channel number

%2 = Block number, label

%3 = Axis, spindle number

%4 = String (+ or -)

During the traversing motion, it is recognized that the working area limitation is reached in the displayed direction. It was not yet possible to detect in block conditioning that the traversing range has been exceeded because there has been a motion overlay by the handwheel.

Reaction:

Alarm display.
Interface signals are set.
NC Start disable.

Remedy: Setting data:
Check 43420 WORKAREA_LIMIT_PLUS and
43430 WORKAREA_LIMIT_MINUS
for the working area limitation.

Program Continuation: Clear alarm with RESET key. Restart part program.

10631 Channel %1 axis %2 rests at working area limit %3

Explanation:

%1 = Channel number

%2 = Axis, spindle

%3 = String (+ or -)

The specified axis reaches the positive working area limitation in **JOG** mode.

Reaction: Alarm display.

Remedy: Setting data:
Check 43420 WORKAREA_LIMIT_PLUS and
43430 WORKAREA_LIMIT_MINUS
for the working area limitation.

Program Continuation: Alarm display disappears with cause of alarm. No further operator action necessary.

10640 Channel %1 block %3 spindle %2 cannot stop during gear change

Explanation:

%1 = Channel number

%2 = Spindle number

%3 = Block number, label

The spindle is in the oscillating mode for a gear change and is waiting for the PLC acknowledgment that the gear change has taken place (interface signal: **Gear has changed** DB 31 - 48, DBX 16.3). During this phase spindle stop is not possible, initiated by **Reset** (DB 21 - 28, DBX 7.7) or **NC Stop axes plus spindle** (DB 21 - 28, DBX 7.4).

Reaction: Alarm display.

Remedy: No remedial measures are necessary. The spindle-specific interface signal **Spindle reset** (DB 31 - 48, DBX 2.2) cancels the oscillation mode.

Program Continuation: Alarm display disappears with cause of alarm. No further operator action necessary.

10720 Channel %1 block %3 axis %2 software limit switch %4

Explanation:

%1 = Channel number

%2 = Axis name, spindle number

%3 = Block number, label %4 = String (+ or -)

For the axis, the programmed path violates the currently valid software limit switch. (The 2nd software limit switch becomes active with the interface signal "2nd software limit switch plus/minus" in DB 31 - 48, DBX 12.2 and 12.3). The alarm is activated when preparing the part program block.

Reaction:

Alarm display.

Interface signals are set.

Correction block with reorganization

NC Start disable.

Remedy: Check the **position** of the axis as specified in the part program.

Machine data: 36100 **POS_LIMIT_MINUS**/36120 **POS_LIMIT_MINUS2** and 36110 **POS_LIMIT_PLUS**/36130 **POS_LIMIT_PLUS2** must be checked for the software limit switches.

Check the axis-specific **interface signals:** "Check 2nd software limit switch plus/minus" (DB 31 - 48, DBX 12.2 and 12.3) to see whether the 2nd. software limit switch is selected.

Check currently active **zero offsets** via the current frame.

Program Continuation: Clear alarm with NC START and continue program.

10750 Channel %1 block %2 tool radius compensation activated without tool no.

Explanation:

%1 = Channel number

%2 = Block number, label

A tool T... must be selected so that the control can make allowance for the associated compensation values.

A correction data block (D1) containing the correction values (parameter P1 - P25) is automatically assigned to each tool (T number). Up to 9 correction data blocks can be assigned to a tool by specifying the required data block with the D number (D1 - D9).

The cutter radius compensation (CRC) is allowed for if function G41 or G42 is programmed. The correction values are contained in parameter P6 (geometry value) and P15 (wear value) of the active correction data block D x.

Reaction:
Alarm display.
Interface signals are set.
Correction block with reorganization
NC Start disable.
NC Stop when alarm at block end.

Remedy: Before calling the CRC with G41/G42, program a tool number under the address T....

Program Continuation: Clear alarm with NC START and continue program.

MMC 100 Messages

The MMC100 has its own set of alarms/messages. The following are most likely to occur during power on and setting up the machine. Alarms/messages not listed can be found in the Siemens control manual.

MMC100 alarms/messages can occur in two different ways:

- as alarm (in the alarm line) or
- as message (in the dialog line) without alarm number.

The user can configure whether the alarms are to be displayed in the alarm line or in the dialog line (without alarm number). For more information, please refer to **References:** /PK/ Configuring Package MMC 100

See the category "Type" which shows whether the alarms/messages are configured as message or alarm at delivery.

101000 No connection to PLC!

Explanation: It was not possible to set up a connection to the PLC during power-up, e.g. incorrect PLC basic program. This can be caused by wiring problems or cable failures.

Type: Message

101002 Password is not valid!

Explanation: An incorrect password has been entered. Commonly due to a typo error.

Type: Message

Remedy: Enter valid password

101151 Start - up successful

Explanation: In the start-up area screen NC Start-up one of the three functions - normal NCK reset
- reset with default values
- software update start was successfully initiated.

- Type:** Message
- 101156** Function illegal
- Explanation:** The selected function is illegal. Commonly occurs when file being requested is not present.
- Type:** Message
- Remedy:** See Installation Guide
- 101160** Date and time of PLC set
- Explanation:** The date or time was changed in the PLC status.
- Type:** Message
- 101205** Drive data changed? -> Don't forget to save boot files!
- Explanation:** On exiting the drive machine data screens, the user is reminded to save the boot files, to ensure that any changes made to the drive machine data are not lost.
- Type:** Message
- 101206** Search operation in progress, please wait...
- Explanation:** The search function has been triggered in the machine data screens.
- Type:** Message

**Machine Operating
Area**

- 103001** Select possible only after enable or in RESET state
- Explanation:** In order to execute the desired function, the current channel must be in the Reset state, e.g. program selection.
- Type:** Message
- Reaction:** -
- Remedy:** Perform a reset
- 103002** You cannot copy into the clipboard
- Explanation:** NCK cannot copy into the clipboard, because, for example, there is not enough memory space available or the maximum possible number of programs it can manage has been exceeded.

Type: Message

Reaction: -

Remedy: Delete the programs that are not currently needed.

103003 You cannot delete the MDA buffer

Explanation: NCK cannot delete the buffer because it is being processed.

Type: Message

Reaction: -

Remedy: Wait until the MDA program has finished processing or perform an NC reset.

103004 Block search not possible

Explanation: Search function cannot be run because the channel is active.

Type: Message

Reaction: -

Remedy: Wait until the program has finished processing or perform an NC reset.

103006 Block search without calculation only possible on main program level

Explanation: It is not possible to process subroutine calls with block search without calculation.

Type: Message

Reaction: -

Remedy: If subroutines are to be processed, block search with calculation must be used.

103007 Termination of overstore is not possible in this channel state

Explanation: It is not possible to terminate overstore, because the channel is still active.

Type: Message

Reaction: -

Remedy: Wait until the overstore process is terminated or perform an NC reset.

- 103008** Block search started in channel %1 - Please wait!
- Explanation:** %1 = Channel number
The started block search is not yet completed.
- Type:** Message
- Reaction:** Text is automatically deleted after block search is terminated.
- Remedy:** Wait until the block search is terminated or perform an NC reset.
- 103009** Conflict between search type and search target!
- Explanation:** The entered search target does not match the search type:
- Block number start character 'N' or ':' is missing.
 - Only numerals between 0 and 9 are allowed.
- Type:** Message
- Reaction:** The faulty entry is retained and the cursor stops on the field.
- Remedy:** Correct the entry according to the type.
- 103010** Invalid file name
- Explanation:** The entered file name
- May be up to 32 characters long (letters, numerals, underscore; including the block and program identifiers: _N_ and _MPF), corresponds to 25 characters that can be used
 - Must not contain separators (e.g. /),
 - Must contain letters in the first and second position.
- Type:** Message
- Reaction:** The faulty entry is deleted.
- Remedy:** Enter a valid file name.
- 103011** No program selected - block search terminated
- Explanation:** A block search is not possible as currently there is no program selected.
- Type:** Message
- Reaction:** -
- Remedy:** Select program.
- 103014** Please reference axis first

Explanation: Reference point approach has not been performed yet or terminated.

Type: Message

Reaction: -

Remedy: Carry out reference point approach.

Fadal 3020 PLC Alarm Messages

The following PLC alarms are specific to the Fadal 3020 application of the Siemens Control.

Oem alarm listing

- 66500** Spindle Orientation Failed
- DEFINITION:** The spindle failed to orient properly.
- REACTION:** Display alarm. Axis movement disable. NC start disable.
- REMEDY:** Check the spindle for proper positioning. Check orientation sensor.
- PROGRAM CONTINUATION:** Clear alarm with Reset key. Restart part program.
- Contact Service.
- 67000** Is The Spindle Empty? If Yes Press Cycle Start To Continue
- DEFINITION:** Verify there is no tool in the spindle before going on with the tool change to avoid damaging the tool magazine. Tool zero is in the spindle.
- REACTION:** Display alarm. Axis movement disable. NC start disable.
- REMEDY:** Verify there is not tool in the Spindle and continue as prompted.
- PROGRAM CONTINUATION:** Continue part program. Contact Service.
- 67001** Load Tool Active
- DEFINITION:** The tool load function is active.
- REACTION:** Display message. Axis movement disable. NC start disable.
- REMEDY:** Normal message during tool load.
- PROGRAM CONTINUATION:** Continue part program. Contact Service. 67002 Tool (Un)load Not Possible; Tool In Spindle
- 67002** Tool (un) load Not Possible; Tool In Spindle.

DEFINITION: The spindle is the load/unload position. If a tool is already there tool loading/unloading is not possible.

REACTION: Display alarm. Axis movement disable. NC start disable.

REMEDY: Call T0 (tool zero) to remove the tool from the spindle.

PROGRAM CONTINUATION: Continue part program. Contact Service.

510008 User Feed Stop

DEFINITION: User has pressed the Feed Stop key.

REACTION: Display alarm. Program interrupted. Axis movement disable.

REMEDY: Remove feed stop condition.

PROGRAM CONTINUATION: Press the Feed Start key or Cycle Start key.

510009 Feed Stop Selected >> Spindle Not Rotating

DEFINITION: User feed stop condition prevents the spindle from starting.

REACTION: Display alarm. Program interrupted. Spindle rotation disable.

REMEDY: Remove feed stop condition.

PROGRAM CONTINUATION: Press the Feed Start key or Cycle Start key.

510010 ATC Not In Home Position

DEFINITION: Automatic Tool changer not in home position.

REACTION: Display alarm. Program interrupted. Axis movement disable. Spindle rotation disable.

REMEDY: Check tool changer mechanism for malfunctions/obstructions. Bring the DATC arm to home position manually.

PROGRAM CONTINUATION: Clear alarm with Reset key. Restart part program. Contact Service.

510011 DATC Magazine Out Of Synchronization: Re-referencing needed

DEFINITION: Tool magazine position count has been lost.

REACTION: Display alarm. NC start disable. Program interrupted.

REMEDY: Bring the tool magazine pocket 1 to tool change position, then run M11.

PROGRAM CONTINUATION: Alarm will re-set by running M11. Restart part program. Contact Service.

510012 Dual Arm Active

DEFINITION: The dual arm gripper in the tool changer in movement.

REACTION: Display alarm. Axis movement disable. Spindle rotation disable.

REMEDY: Normal during tool change. Check dual-arm tool changer interface if displayed outside tool change.

PROGRAM CONTINUATION: Clear alarm with Reset key. Restart part program. Contact Service.

510100 DATC Arm Motor Overload

DEFINITION: Dual arm tool changer arm motor overload tripped.

REACTION: Display alarm. Axis movement disable. Program interrupted.

REMEDY: Check DATC arm for mechanical problems. Check DATC arm motor, brake, and electrical connections. Re-set DATC arm motor overload sensor.

PROGRAM CONTINUATION: Clear alarm with Reset key. Restart part program. Contact Service.

510101 DATC Magazine Motor Overload

DEFINITION: Dual arm tool changer magazine motor overload tripped.

REACTION: Display alarm. Axis movement disable. Program interrupted.

REMEDY: Check DATC magazine for mechanical problems. Check DATC magazine motor, brake, and electrical connections. Re-set DATC magazine motor overload sensor.

PROGRAM CONTINUATION: Clear alarm with Reset key. Restart part program. Contact Service.

510102 DATC Arm Time-out

DEFINITION: Dual arm tool changer arm failed to move in time allowed.

REACTION: Display alarm. Axis movement disable. Program interrupted.

REMEDY: Check DATC arm for mechanical problems. Check DATC motor and electrical connections. Check any conditions that will prevent the DATC from normal function (door open, lack of compressed air, etc.)

PROGRAM CONTINUATION: Clear alarm with Reset key. Restart part program. Contact Service.

510103 DATC Magazine Time-out

DEFINITION: Dual arm tool changer magazine failed to move in time allowed.

REACTION: Display alarm. Axis movement disable. Program interrupted.

REMEDY: Check DATC magazine for mechanical problems. Check DATC magazine motor and electrical connections. Check any conditions that will prevent the DATC from normal function (lack of compressed air, motor brake malfunction, etc.)

PROGRAM CONTINUATION: Clear alarm with Reset key. Restart part program. Contact Service.

510104 DATC Tool Pocket Time-out

DEFINITION: Dual arm tool changer tool pocket failed to move in time allowed.

REACTION: Display alarm. Axis movement disable. Program interrupted.

REMEDY: Check DATC tool pocket for mechanical problems. Check any conditions that will prevent the DATC from normal function (door open, lack of compressed air, etc.) Check tool pocket actuation valves, electrical connection, fuses.

PROGRAM CONTINUATION: Clear alarm with Reset key. Restart part program. Contact Service.

510105 Spindle Draw Bar Arm Time-out

DEFINITION: Draw bar mechanism failed to close/open in time allowed.

REACTION: Display alarm. Axis movement disable. Program interrupted.

REMEDY: Check draw bar for mechanical problems, lack of compressed air. Check spindle for jammed tools. Check any conditions that will prevent the DATC from normal function (door open, lack of compressed air, etc.)

PROGRAM CONTINUATION: Clear alarm with Reset key. Restart part program. Contact Service.

510106 Z Axis Not In Tool Change Position

DEFINITION: DATC is prevented to move because Z axis is not in position.

REACTION: Display alarm. Axis movement disable. Program interrupted.

REMEDY: Move the Z axis to the cold start position. Check the Z-axis-in-position sensor. Verify Cold Start position.

PROGRAM CONTINUATION: Clear alarm with Reset key. Restart part program. Contact Service.

510124 ATC Active

DEFINITION: Automatic Tool Changer in movement.

REACTION: Display alarm. Axis movement disable. Spindle rotation disable.

REMEDY: Normal during tool change. Check ATC mechanism if displayed outside tool change.

PROGRAM CONTINUATION: Clear alarm with Reset key. Restart part program. Contact Service.

510125 Gear Change In Progress

DEFINITION: Spindle is undergoing a gear change.

REACTION: Display alarm. Program interrupted. Spindle rotation disable.

REMEDY: Normal during spindle speed range change. Check belt actuators and /or sensors. Contact Service.

PROGRAM CONTINUATION: Alarm must clear after a few seconds. Power machine off and on. Contact Service.

510126M5 In Progress

DEFINITION: Spindle stop command in progress

REACTION: Display alarm. Spindle rotation stopped.

REMEDY: Normal during spindle stop.

PROGRAM CONTINUATION: Alarm must clear once spindle stops. Contact Service.

510127ATC Motor Failure

DEFINITION: Automatic Tool Changer failure. Tool changer board failure. Geneva type only: Magazine failed to rotate.

REACTION: Display alarm. Program interrupted. Spindle rotation disable.

REMEDY: Press Reset key. Check tool changer board for failures. Reset tool changer board if needed ONLY AFTER CONTROL RESET. Check tool changer for mechanical problems. Check air pressure to machine (air-oil board is interlocked). Check emergency stop hardware loop (110VAC circuit is also interlocked).

PROGRAM CONTINUATION: Alarm clears when tool changer board is working O.K. Contact Service.

510128 ATC only 21 Tools

DEFINITION: The tool changer is a 21 tool type and an attempt has been made to use more than 21 tools.

REACTION: Display alarm. Program interrupted. Spindle rotation disable.

REMEDY: Check the tool number being called. Check the options available for the machine.

PROGRAM CONTINUATION: Press Reset key. Contact Service.

510200 Option Rigid Tapping Not Available

DEFINITION: Rigid tapping was tried in a machine not equipped with this option.

REACTION: Display alarm. Program interrupted (read-in disabled).

REMEDY: Check the options available for the machine.

PROGRAM CONTINUATION: Press Reset key. Contact Service.

510216 Oiler level too low

DEFINITION: Way-lube oiler level too low.

REACTION: Display alarm. Program interrupted (read-in disabled).

REMEDY: Fill up way-lube oiler reservoir. Program will continue automatically.

PROGRAM CONTINUATION: Program will continue as soon as oil level is high again. Press Reset key. Contact Service.

510300 POWER ON Needed To Set Spindle Set Up

DEFINITION: M83 has been run to measure the spindle belts.

REACTION: Display alarm. NC-start disabled.

REMEDY: Power the machine off and on.

PROGRAM CONTINUATION: Power the machine off and on. Contact Service.

510308 Tool Loading Active

DEFINITION: The tool loading function is active. A tool loading into the magazine is taking place.

REACTION: Display alarm. NC-start disabled.

REMEDY: Normal during tool loading. If tool loading is interrupted and alarm lingers, power machine off and on and try tool loading/unloading again.

PROGRAM CONTINUATION: Press Reset key. Alarm must be cleared to run programs. Contact Service.

510309 Tool Unloading Active

DEFINITION: The tool unloading function is active. A tool unloading from the magazine is taking place.

REACTION: Display alarm. NC-start disabled.

REMEDY: Normal during tool unloading. If tool unloading is interrupted and alarm lingers, power machine off and on and try tool loading/unloading again.

PROGRAM CONTINUATION: Press Reset key. Alarm must be cleared to run programs. Contact Service.

600108 User Spindle Stop

DEFINITION: The spindle stop key in the machine control panel has been pressed.

REACTION: Display alarm. Axis movement disable. Spindle rotation disable.

REMEDY: Press the spindle start (green key) in the machine control panel. Press the Reset key. Press the Cycle Start key.

PROGRAM CONTINUATION: Press the Cycle Start key. Contact Service.

600109 Spindle Stop LOCK

DEFINITION: The mechanical lock for spindle orientation is engaged.

REACTION: Display alarm. Spindle rotation disable.

REMEDY: Normal during tool change. Appears when using M19 and M101.

PROGRAM CONTINUATION: Call an M5 command. Press Reset key. Contact Service.

700032 X Axis Needs Referencing

DEFINITION: The "X" axis has not been referenced (cold started).

REACTION: Display alarm. NC-start disabled until all axes are referenced.

REMEDY: Reference (cold start) the axis.

PROGRAM CONTINUATION: Reference (cold start) ALL axes. Contact Service.

700033 Y Axis Needs Referencing

DEFINITION: The “Y” axis has not been referenced (cold started).

REACTION: Display alarm. NC-start disabled until all axes are referenced.

REMEDY: Reference (cold start) the axis.

PROGRAM CONTINUATION: Reference (cold start) ALL axes. Contact Service.

700034 Z Axis Needs Referencing

DEFINITION: The “Z” axis has not been referenced (cold started).

REACTION: Display alarm. NC-start disabled until all axes are referenced.

REMEDY: Reference (cold start) the axis.

PROGRAM CONTINUATION: Reference (cold start) ALL axes. Contact Service.

700035 A Axis Needs Referencing

DEFINITION: The “A” axis has not been referenced (cold started).

REACTION: Display alarm. NC-start disabled until all axes are referenced.

REMEDY: Reference (cold start) the axis.

PROGRAM CONTINUATION: Reference (cold start) ALL axes. Contact Service.

700036 B Axis Needs Referencing

DEFINITION: The “B” axis has not been referenced (cold started).

REACTION: Display alarm. NC-start disabled until all axes are referenced.

REMEDY: Reference (cold start) the axis.

PROGRAM CONTINUATION: Reference (cold start) ALL axes. Contact Service.

700039 Doors Open

DEFINITION: Doors-closed monitoring circuit open.

REACTION: Display alarm. User Feed Stop. User Spindle Stop.

REMEDY: Check doors to be completely closed. Check doors-closed monitoring circuit (sensors, etc). Check air pressure, air-oil board and auger board (interlocked).

PROGRAM CONTINUATION: Close doors. Use the Override button in JOG (Manual) mode. Contact service.

700040 Handwheel Available Only In Jog Mode

DEFINITION: MPG or INC keys pressed while in Automatic mode.

REACTION: Display alarm.

REMEDY: Change over to JOG (Manual) mode before using the handwheel.

PROGRAM CONTINUATION: Contact service if alarm lingers.

700041 Feed Override = 0

DEFINITION: A manual movement was attempted while the Feed Override is set to zero.

REACTION: Display alarm.

REMEDY: Set Feed Override knob to desired setting other than zero. Check Feed Override switch.

PROGRAM CONTINUATION: Set Feed Override knob to desired setting other than zero. Contact Service.

700042 Please Press MDA Soft Key

DEFINITION: MDA hard key was pressed when in Shop Mill.

REACTION: Display alarm.No change to MDA mode until MDA soft key (menu under the screen) is used.

REMEDY: Use MDA soft key to change over to MDA mode in Shop Mill.

PROGRAM CONTINUATION: Contact Service if alarm lingers.

Section 04: Action List

No.	Explanation	Not allowed, if	Remedy
1.	Carry out Init phase (tasks are initialized after Power On)		
2.	Carry out Reset (VDI signal: after Reset, mode group Reset or Power On)		
3.	Activate Reset Init blocks (VDI signal: after Reset)		
4.	Carry out Reset, end of program has been detected (NC block with M30)		
5.	Change the mode to the MDA or AUTOMATIC program operating mode (VDI signal: mode group)	<ol style="list-style-type: none"> 1. The channel is active (program running, block search, loading machine data) 2. The other program operating mode has already been started. 3. A channel has exited the mode group due to an interrupt. 4. Overstore or digitizing has been selected. 	<p>⇒ Abort the program with the Reset key or stop the program (not with block search, loading machine data)</p> <p>⇒ Abort the program with the Reset key</p> <p>⇒ Abort the program with the Reset key or wait until the interrupt is terminated.</p> <p>⇒ Deactivate overstore, digitizing</p>
6.	Automatic change from an internal mode to the mode that was externally set (with TEACH_IN an attempt is made after every stop to change from the internal mode "AUTOMATIC, MDA" to TEACH_IN)		

No.	Explanation	Not allowed, if	Remedy
7.	Change the mode to a manual mode (VDI signal: JOG, TEACH_IN, REF)	<p>1. Nesting depth too great: The current processing operation can be interrupted by various events (e.g. interrupt). Depending on the event, asynchronous subroutines are activated. These asynchronous subroutines can be interrupted in the same manner as the user program. Unlimited nesting depth is not possible for asynchronous subroutines due to memory limitations.</p> <p>2. The channel is active (program running, block search, loading machine data)</p> <p>3. A channel has exited the mode group due to an interrupt.</p> <p>4. Overstore or digitizing has been selected.</p>	<p>⇒ Abort program by activating the Reset key</p> <p>⇒ Abort the program with the Reset key or stop the program (not with block search, loading machine data)</p> <p>⇒ Abort the program with the Reset key or wait until the interrupt is terminated.</p> <p>⇒ Deactivate overstore / digitizing</p>
8.	Activate overstore (PI command).		
9.	Deactivate overstore (PI command).		
10.	Synchronize preprocessing and main run, e.g. on activation of axis control (VDI signal: follow-up mode)		

No.	Explanation	Not allowed, if	Remedy
11	Perform user interrupt "Asynchronous subroutine"(VDI signal: digital-analog interface, synchronous subroutine interface).	1. The channel is active due to block search or loading machine data 2. The channel is stopped and the asynchronous subroutine "ASUP_START_MASK" must be started and the current block cannot be reorganized. 3. Digitizing has been selected 4. Reference point approach has not been performed yet 5. The active block, after which deceleration takes place, cannot be reorganized (occurs when deceleration takes place over several blocks).	⇒ Wait until the block search or loading machine data is completed, or abort program by activating the Reset key. ⇒ Activate a block change until the NC block has been reorganized. ⇒ Deactivate digitizing ⇒ Perform reference point approach or ignore this state via the machine data "ASUP_START_MASK". ⇒ Abort program
12	Perform user interrupt "ASUP" with rapid retraction (VDI signal: digital-analog interface)	See 11	
13	Perform user interrupt at block end (VDI signal: digital-analog interface)	See 11	
14	Perform rapid retraction (VDI signal: digital-analog interface and synchronous subroutine interface). Further actions are: 11, 12, 13, 88, 89).		
15	Move tool - only with tool management (PI command)		
16	Carry out delete distance-to-go (VDI signal: delete distance-to-go, synchronous actions)	1. Nesting depth too great 2. The active block, after which deceleration takes place, cannot be reorganized (occurs when deceleration takes place over several blocks).	⇒ Abort program ⇒ Abort program

No.	Explanation	Not allowed, if	Remedy
17	Perform rapid delete distance-to-go. There is no subsequent reorganization of block processing (VDI signal: delete distance-to-go, synchronous actions)		
18	Perform rapid delete distance-to-go. There is no subsequent reorganization and no stop motion. (VDI signal: delete distance-to-go, synchronous actions)		
19	Abort the subroutine repetition (VDI signal: delete subroutine number of passes)	<ol style="list-style-type: none"> 1. Nesting depth too great 2. The active block, after which deceleration takes place, cannot be reorganized (occurs when deceleration takes place over several blocks). 	<p>⇒ Abort program</p> <p>⇒ Abort program</p>
20	Abort subroutine execution. (VDI signal: abort program level)	<ul style="list-style-type: none"> • Nesting depth too great • The active block, after which deceleration takes place, cannot be reorganized (occurs when deceleration takes place over several blocks). 	<p>⇒ Abort program</p> <p>⇒ Abort program</p>
21	Activate single block (VDI signal: activate single block)		
22	Deactivation of single block. (VDI signal: activate single block)		
23	Activate main run single block. (OPI variable and VDI signal: activate single block)		
24	Activate decoding single block. (OPI variable and VDI signal: activate single block)	<ol style="list-style-type: none"> 1. Nesting depth too great: 2. The active block, after which deceleration takes place, cannot be reorganized (occurs when deceleration takes place over several blocks). 	<p>⇒ Wait until the preceding asynchronous subroutine is terminated or abort the program</p> <p>⇒ Abort program</p>
25	Activate main program single block. (OPI variable and VDI signal: activate single block)		

No.	Explanation	Not allowed, if	Remedy
26	Activate traversing single block. (OPI variable and VDI signal: activate single block)		
27	Start program processing. (VDI signal: NC Start)	<ol style="list-style-type: none"> 1. Program state active, 2. An alarm reaction is pending; it prevents a start or forces braking. 3. Reference point approach has not been performed yet 	<p>⇒ -</p> <p>⇒ Execute condition for deleting alarm</p> <p>⇒ Reference point approach</p>
28	Start program processing. (Channel communication, NC block: Start)	<ol style="list-style-type: none"> 1. Program state active 2. An alarm reaction is pending; it prevents a start or forces braking. 3. Reference point approach has not been performed yet. 4. An incorrect operating mode has been selected. (AUTOMATIC only) 	<p>⇒ Protect Start with WAITE</p> <p>⇒ Execute condition for deleting alarm</p> <p>⇒ Reference point approach</p> <p>⇒ Select program operating mode</p>
29	Start continuation of program processing. (VDI signal: NC Start)	<ol style="list-style-type: none"> 1. Program state active, 2. An alarm reaction is pending; it prevents a start or forces braking. 3. Reference point approach has not been performed yet 	<p>⇒ -</p> <p>⇒ Execute condition for deleting alarm</p> <p>⇒ Reference point approach</p>
30	Start continuation of the selected processing --JOG, reference point or digitizing--. (VDI signal: NC Start)	<ol style="list-style-type: none"> 1. Jog motion active 2. An alarm reaction is pending; it prevents a start or forces braking. 	<p>⇒ -</p> <p>⇒ Execute condition for deleting alarm</p>
31	Start processing in the submode digitizing. (VDI signal: NC Start)	<ol style="list-style-type: none"> 1. Jog motion active 2. An alarm reaction is pending; it prevents a start or forces braking. 3. Reference point approach has not been performed yet 	<p>⇒ -</p> <p>⇒ Execute condition for deleting alarm</p> <p>⇒ Reference point approach</p>
32	Stop all axes. (VDI signal: Stop All or via Reset key)		
33	Perform a program stop. (NC block: M0)		
34	Stop the JOG motion. (VDI signal: NC Stop)		
35	Stop digitizing processing. (VDI signal: NC Stop)		
36.	Start the selected processing. (VDI signal: NC Start)	<ol style="list-style-type: none"> 1. Process change active (operating mode change, switch digitizing ON/OFF, switch overstore ON/OFF) 2. An alarm reaction is pending; it prevents a start or forces braking. 3. A process is running (NC program, block search, loading machine data) 	<p>⇒ -</p> <p>?</p> <p>Execute condition for deleting alarm</p> <p>⇒ -</p>

No.	Explanation	Not allowed, if	Remedy
37	Stop the active processing. (VDI signal: NC Stop)		
38	Start machine data processing (INI file is already in the NCK), (PI command)		
39	Start machine data processing (INI file is external, e.g.: on MMC), (PI command)		
40	Stop because of mode group single block. VDI signal, single type A (only executable blocks), after stop in another channel in this mode group		
41	Stop because of mode group single block. VDI signal, single type A (any blocks), after stop at block end in another channel in this mode group		
42	Stop because end of overstore buffer "_N_OSTOREXX_SYF" has been reached.		
43	Start preprocessing (NC block: Stopre)		
44	Stop processing at block end. (NC block: M00/M01)		
45	Stop processing at block end. (Alarm, VDI signal: NC stop at block end)		
46	Stop at end of asynchronous subroutine, if start was performed from "stopped".		
47	Activate program. (PI command)		
48	Activate the program which is still external. (PI command)		
49	Program selection from another channel. (Channel communication, NC block: INIT)		
50	Save definition of an asynchronous subroutine. (PI command)		
51	Sets all machine data with the attribute (NEW_CONF) active. (PI command)		

No.	Explanation	Not allowed, if	Remedy
52	Delete all alarms with the delete condition CANCELCLEAR (PI command, acknowledge alarm key)		
53	Continue block search. (NC block, Stopre)		
54	Start block search. (PI command)		
55	Continue block search. (PI command)		
56	Activate digitizing. (PI command)		
57	Deactivate digitizing. (PI command)		
58	Switch on function generator. (PI command)		
59	Switch off function generator. (PI command)		
60	Wait for a program marker. (Channel communication, NC block: WAITM)		
61	Wait for an end of program. (Channel communication, NC block: WAITE)		
62	Program selection from another channel, synchron. (Channel communication, NC block: INIT)		
63	Wait until receive acknowledge from MMC. (NC block, MMC_CMD)		
64	Activate the skip block function (VDI signal: skip block)	Nesting depth too great	⇒ Wait until the preceding asynchronous subroutine is terminated or abort the program
65	Deactivate the skip block function (VDI signal: skip block)	Nesting depth too great	⇒ Wait until the preceding asynchronous subroutine is terminated or abort the program
66	Activate testrun. (VDI signal: rapid traverse overlay)	1. Nesting depth too great: 2. The active block, after which deceleration takes place, cannot be reorganized (occurs when deceleration takes place over several blocks).	⇒ Wait until the preceding asynchronous subroutine is terminated or abort the program ⇒ Abort program

No.	Explanation	Not allowed, if	Remedy
67	Deactivate testrun. (VDI signal: rapid traverse overlay I)	<p>1. Nesting depth too great</p> <p>2. The active block, after which deceleration takes place, cannot be reorganized (occurs when deceleration takes place over several blocks).</p>	<p>⇒ Wait until the preceding asynchronous subroutine is terminated or abort the program</p> <p>⇒ Abort program</p>
68	Activate read-in disable for main run block. (VDI signal: read-in disable)		
69	Deactivate read-in disable for main run block. (VDI signal: read-in disable)		
70	Stop at block end. (Alarm)		
71	Stop all axes. (Alarm)		
72	Activate program test. (VDI signal: program test)	<p>1. Tool management is active.</p> <p>2. The NCK channel state is not ready</p>	<p>⇒ Save tool data</p> <p>⇒ Abort the program or process with the Reset key or wait for end of program.</p>
73	Deactivate program test. (VDI signal: program test)	The NCK channel state is not ready	⇒ Abort the program or process with the Reset key or wait for end of program.
74	Stop at the end of block preparation. (Alarm)		
75	Stop at the end of block preparation with subsequent reorganization of block processing. (Alarm)	Nesting depth too great	⇒ Wait until the preceding asynchronous subroutine is terminated or abort the program
76	Conditional stop at block end. (If, after continuation by means of an NC start, there is still a reason to stop "Stop at block end", the program stops again).		
77	Conditional stop at block end. (Despite the start, the interpreter or the preprocessing does not manage to put a block in main run)		
78	Stop preprocessing. (Alarm)		
79	Retraction motion with G33 and Stop.		

No.	Explanation	Not allowed, if	Remedy
80	Conditional wait for program marker (NC block: WAITMC)		
81	Set marker. (NC block: SETM)		
82	Clear marker (NC_block: CLEARM)		
83	Selection of an NC block. (PI command)		
84	Disable the NC program which is currently being processed for editing. (PI command)		
85	Start a program in the TEACH IN submode. (VDI signal: NC Start)	See 36 and 5	
86	Continue a program in the TEACH IN submode. (VDI signal: NC Start)	See 36 and 5	
87	Reorganize block processing.		
88	Activate user interrupt "asynchronous subroutine" in a manual mode. (VDI signal: synchronous subroutine interface, digital-analog interface)	See 11	
89	Activate user interrupt "asynchronous subroutine". Is only performed in READY channel status. (VDI signal: synchronous subroutine interface, digital-analog interface)	See 11	
90	Perform user interrupt "Asynchronous subroutine". (VDI signal: synchronous subroutine interface, digital-analog interface; Further actions are: 11, 12, 13, 88, 89)	See 11	
91	Stop processing. (VDI signal: mode group Stop)		
92	Set all machine data with the attribute (NEW_CONF) active. (NC block: NEW_CONF)		
93	Set all machine data with the attribute (NEW_CONF) active. (NC block: NEW_CONF at block search)		

No.	Explanation	Not allowed, if	Remedy
94	Start continuation of interpreter processing. (internal preprocessing stop)		

Section 05: Compensation





5.1 Cold Start Position

5.1.1 SET OFFSETS

The SET OFFSETS program allows the user to align the machine to its proper cold start position. Every time the control is referenced to the cold start position, it looks for the one-pulse-per-revolution signal emitted from the encoder. To do this, the motor is turned in a given direction until the encoder emits this signal. This is the electronic zero position.

Because the rotor position can vary in relation to the machine, the electronic zero and mechanical zero (cold start) may not be the same. Therefore, the electronic zero and mechanical zero needs to be aligned using “offset.” Offset is the distance needed to go from the point where the machine stops after referencing and the point where it should be to have the cold start marks aligned.

The following steps describe how to use the SET_OFFSETS program:

1. Power the machine off and back on.
2. Press the MPG  hard key. The LED above the key should illuminate.
3. Select an axis using the axis selector switch--on the MPG panel.
4. Jog the selected axis to its cold start alignment mark. The alignment does not have to be exact.
5. Repeat steps 3 and 4 for all the axes.
6. Press the JOG  hard key. This turns off the MPG.
7. Press the REF POINT  hard key.
8. Select an axis using the axis selector switch--on the MPG panel.
9. Press the “plus”  hard key. The crosshair symbol  will display to the left of the selected axis when referenced.
10. Repeat steps 8 and 9 for all axes.

NOTE: The control will show a distance value of zero for the axes as they are referenced. If the value is different, make sure the base value is set to zero and the tool offset is cleared using D0.

11. Re-align cold start marks. Press the MPG  hard key. The LED above the key should illuminate.

12. Select an axis using the axis selector switch--on the MPG panel.

13. Jog the selected axis to its cold start alignment mark.

The value shown on the screen display is the distance between the electronic zero value and the mechanical value (cold start position).

14. Load the SET_OFFSETS programs. Press the PROGRAM MANAGER hard key. (For MMC103: First, press the Menu select  hard key; then, press the Program Manager soft key.)

15. Select SET_OFFSETS in the directory.

16. Press the EXECUTE soft key. The program is loaded and ready to run.

17. Press the CYCLE START  hard key. Wait until the program is done.

18. Power the machine off and back on.

19. Reference each axis (see steps 7, 8, 9, and 10) and check for proper cold start position.

NOTE: If only one axis needs re-alignment, then work only on *that* particular axis. Leave the other axes at their cold start positions throughout the whole procedure. The cold start position can then be fine-tuned for a particular position (like the Z-axis alignment for tool changes).

5.2 Spindle Belt

5.2.1 M83 Program



Fadal machines are built with spindles that are belt-driven. The spindle belts are manufactured to specified tolerances, but they are not always perfect. They can be manufactured either a little shorter or a little longer than specifications. To compensate for this, the M83 program is needed.

The M83 program is designed to measure the spindle belt and enter the appropriate values in the corresponding machine data. The values are used to establish the proper relationship between the motor pulley and the spindle pulley.

In order to obtain the best values possible, the M83 program should be run a minimum of two times--powering the machine off each time. The reason this is done twice is because the new belt and the values may need to be changed more than once to obtain the proper relationship. Every pulse in the encoder of the motor represents an allowable amount of movement of the spindle. When a belt is new, the exact relationship of how much a single encoder pulse represents in spindle movement has not been established yet.

M83 measures the relationship between the motor and the spindle by counting the number of pulses it takes for one revolution of the spindle. This creates a guideline for the correct numbers needed.



The following steps describe how to use the M83 program:

20. Press the JOG  hard key.
21. Press the T,S,M... soft key.
22. Enter 83 in the *OTHER M FCT.* field.
23. Press the INPUT  hard key.
24. Press the CYCLE START  hard key.
25. Wait for the *power off* message from the program.
26. Power the machine off and back on.

5.2.2 M84 Program

M84 is the complement to M83. While the M83 establishes the parameters for the spindle-motor relationship, the M84 program fine tunes that relationship.

The following steps describe how to use the M84 program:

27. Press the JOG  hard key.
28. Press the T,S,M... soft key.
29. Enter 84 in the *OTHER M FCT.* field.
30. Press the INPUT  hard key.
31. Press the CYCLE START  hard key.
32. Wait for the program to finish executing.

There is no need to power off and back on.







5.3 Axis Backlash

5.3.1 COMP_VALUES_n

The COMP_VALUES_n (where n is x, y, z, etc.) program is used to enter the ball screw error compensation values one axis at a time. These values allow the control to compensate for inaccuracies commonly found in the ball screw. Therefore, the control can setup very precise positioning for the ball screw. The program will automatically enter the data for the measurement system, either the motor encoder or linear scales, that the machine is equipped with.

The measurement is made in one inch increments. The program LASER_n can be used for that purpose or the user can make their own.

The following steps describe how to use the COMP VALUES program:

- Run measuring program and measure pitch error.
 33. Press the PROGRAM MANAGER hard key. (For MMC103: First, press the Menu select  hard key; then, press the Program Manager soft key.)
 34. Select LASER_n in the directory.
 35. Press the CYCLE START  hard key.
 36. Take measurements.
- Open the corresponding COMP_VALUES_n program.
 37. Press the PROGRAM MANAGER hard key. (For MMC103: First, press the Menu select  hard key; then, press the Program Manager soft key.)
 38. Select COMP_VALUES_n in the directory.
 39. Press the INPUT  hard key.
- Enter the corresponding compensation values.
 40. Use the arrows to edit values as needed. See the example at the end of this procedure.
 41. Go to the start of the program using the PAGE UP  hard key.
 42. Press the MACHINE FROM HERE soft key to load the program.
 43. Press the CYCLE START  hard key. The program will load the compensation values into memory.
 44. Reference the axis and check for proper cold start position.

NOTE: Run the COMP_VALUES_n program, from the beginning, whenever the machine is changed to/from metric or inches. The original values, in inches, must be used, as they are automatically converted.

Figure 1 shows a sample printout from a laser measurement system.

```

RENISHAW CALIBRATION INTERFEROMETER SYSTEM
ERROR COMPENSATION TABLE

MACHINE VMC 3020                SERIAL No:XXXX
DATE:xxxxx                      By:
Axis: Y AXIS                    Location:-9
Title:Y SURVEY                  Filename: Data Capture
Table Type                       Combined table with backlash value
Compensation type                Absolute
Compensation resolution          0.0001 in
Reference position               -9.00000 in
Compensation start               -9.00000 in
Compensation end                 10.00000 in
Compensation spacing            1.00000 in

Backlash value                   0.0000 in

                                Compensation values

No.      Axis position          Combined
          (in)                  (0.0001 in)
1         -9.00000              0
2         -8.00000              -1
3         -7.00000              -2
4         -6.00000              -2
5         -5.00000              -3
6         -4.00000              -3
7         -3.00000              -4
8         -2.00000              -4
9         -1.00000              -4
10        0.00000               -4
11        1.00000               -4
12        2.00000               -4
13        3.00000               -4
14        4.00000               -5
15        5.00000               -4
16        6.00000               -5
17        7.00000               -5
18        8.00000               -6
19        9.00000               -6
20       10.00000              -7

```

Figure 5-1. A typical printout of compensation values from the output of a laser measurement system.

Figure 2 shows a partial view of the COMP_VALUES_Y survey values from the printout in Figure 1. The numbers within the brackets, [], are “pointers.” They correspond to the position numbers in the compensation values printout.

```

;-----BEGINNING--OF--SURVEY-----
;----- Y AXIS -----
_COMPVALUE[0]=0.0000      ;ALWAYS ZERO
_COMPVALUE[1]=0.0000      ;ALWAYS ZERO
_COMPVALUE[2]=-0.0001
_COMPVALUE[3]=-0.0002
_COMPVALUE[4]=-0.0003
_COMPVALUE[5]=-0.0003
_COMPVALUE[6]=-0.0004
_COMPVALUE[7]=-0.0004
_COMPVALUE[8]=-0.0004
_COMPVALUE[9]=-0.0004
_COMPVALUE[10]=-0.0004
_COMPVALUE[11]=-0.0004
_COMPVALUE[12]=-0.0004
_COMPVALUE[13]=-0.0004
_COMPVALUE[14]=-0.0005
_COMPVALUE[15]=-0.0004
_COMPVALUE[16]=-0.0005
_COMPVALUE[17]=-0.0005
_COMPVALUE[18]=-0.0006
_COMPVALUE[19]=-0.0006
_COMPVALUE[20]=-0.0007

```

Figure 5-2. A partial view of survey values from a COMP_VALUES_n program.

Example:

The “_COMPVALUE[1]=0.0000” survey value corresponds to “No. 1” in the printout and the “_COMPVALUE[6]=-0.0004” survey value corresponds to “No. 6” in the printout.

NOTE: For A and B axes, position number one corresponds to pointer zero; That is, “_COMPVALUE[0]=0.0000” corresponds to “No. 1” of the printout and “_COMPVALUE[6]=-0.0004” corresponds to “No. 7” of the printout.

5.4 Reset Tool Magazine

5.4.1 TC_BASE



The TC_BASE program resets the contents of the tool magazine. Every time the tool data is lost, for any reason, this program returns the magazine to a state where all the tools are in the magazine and none are in the spindle.

The tool offsets will be reset to zero, in both length and diameter.

The following steps describe how to use the TC_BASE program:

IMPORTANT

After using TC_BASE, remember to remove any tool from the spindle before calling a tool. When there is no tool assigned to the spindle, the tool changer will go directly to the magazine to load a new tool. If there is a tool already in the spindle, the automatic tool changer may incur severe damage.

45. Press the JOG  hard key.
46. Press the MDA  soft key.
47. Enter "TC_BASE"
48. Press the CYCLE START  hard key.
49. The control will show a message. Then, alarm *510300* will appear.
50. Power the machine off and back on.
51. Once the machine is ready to run again, remove any tool from the spindle and call a tool. Enter tool data as needed.

Section 06: MMC100 Software Update

IMPORTANT! If the VMC is equipped with a DATC, please see page 35.

NOTE: You **must** install the appropriate software and hardware for DATC.

General Information

Before performing this software update, **READ THROUGH THE PROCEDURE AT LEAST ONE TIME, COMPLETELY.** This will ensure a more effective error-free update. Also verify the configuration of the Siemens control using WRG-0002 REV F (See the wiring diagram at the end of this document). If the configuration does not match what is on your Siemens control, **DO NOT PROCEED WITH THIS UPDATE UNTIL THE MACHINE IS CONFIGURED CORRECTLY.**

It is important that a COMPLETE BACK-UP is made of the current machine data before performing software update. If an error is made in the software update of the machine data, the back-up file can be used to restore the system to its original configuration.

Part number information for the Software Update Kit and its components can be found in Appendix B of this manual.

List of Components

- PC card containing original.arc file and hmi.abb operating system
- NC card containing original.arc file and nck.abb operating system
- A pre-imaged hard drive (MMC103 only)
- Utilities disk

The hmi.abb and nck.abb files are required for updating the display. These files are stored on PC cards. The hmi.abb file contains the necessary firmware for the display. The nck.abb file is the system software that resides on an NC card (PCMCIA).



Figure 7 The files for performing the MMC100 software update are stored on two PC cards and Utilities disk.

The pre-imaged hard drive replaces the existing hard drive on the MMC100 module. The pre-imaged hard drive contains software tools that is used to restore the machine.

Tools Required

MMC100

- An external computer, either a laptop computer or desktop PC (personal computer). The external computer hard disk is used to store the backup files from the 810D control.
- The PCIN communications program, supplied by Fadal, installed on the external computer.
- A 9-pin to 9-pin RTS/CTS 5-wire null modem serial communications cable

MMC100 Update Procedure

The overview of this update procedure is as follows:

1. Do a complete backup of machine tool data.
2. Back up existing program files, such as, customer offsets, programs, and tool fixtures.
3. Save backlash CS offsets survey (get values).
4. Install new NC card (contains NC OS and **original.arc** file)
5. Reset PLC.
6. Install new HMI firmware from PC card.
7. Restore the NCK and load the **original.arc** file from the NC card.
8. Run Options program.
9. Update comp data and backlash, if needed. Use xyz comps.
10. Load compensation values.
11. Create two (2) copies of new system files for back up. One copy will be kept with the machine. The other copy, *with the machine serial number*, will be sent to Fadal.



This software update procedure starts from power-on.

1. Pre-Software Update Set Up

- a. Plug one end of the 9-pin RTS/CTS serial communications cable to the serial port at the external computer.
- b. Go to the pendant and unlatch the door to allow access to the MMC100 inside the pendant cabinet.
- c. Plug the other end of the serial communications cable to the COM1 serial port on the MMC100.

2. Call Tool Zero (Unload spindle)

The following steps sets up the machine and saves the spindle tool data:

- a. Power the machine OFF and back ON.
- b. Press the JOG button.
- c. Reference each axis.
 - Select an axis with the axis selector switch.
 - Press  REF POINT hard key.
 - Press  (plus) hard key.
 - Repeat these steps for all the configured axes.
 - The axes are referenced when the crosshair symbol  displays to the left of each axis.
- d. Press the JOG button.
- e. Press the T.S.M. soft key.
- f. Enter 0 in the “T” field.
- g. Press the INPUT hard key.
- h. Press the CYCLE START button.

Tool zero (0) will be loaded into the spindle. Verify by checking the *T,F,S* box in the upper right portion of the screen. No data will be displayed to the right of the T if tool 0 is loaded.

3. Recording Original Cold Start Position, Backlash Data and Gain Settings

- a. Press MENU SELECT hard key.
- b. Select START-UP soft key.
- c. Wait for Startup screen to load.
- d. Press Machine data
- e. Press **Axis specific**
- f. Go to machine data for each axis and record the following using the + soft key located on the upper right portion of the screen, choose **X1**
using the blue arrows go to 34090 REFP_MOVE_DIST [0]

NOTE: [0] = ENCODER [1] = SCALE

Record this data:

34090 REFP_MOVE_DIST [0] _____

34090 REFP_MOVE_DIST [1]_____

using the + soft key located on the upper right portion of the screen,
choose **Y1**

using the blue arrows go to 34090 REFP_MOVE_DIST [0]

record the data:

34090 REFP_MOVE_DIST [0]_____

34090 REFP_MOVE_DIST [1]_____

using the + soft key located on the upper right portion of the screen,
choose **Z1**

using the blue arrows go to 34090 REFP_MOVE_DIST [0]

record the data:

34090 REFP_MOVE_DIST [0]_____

34090 REFP_MOVE_DIST [1]_____

using the + soft key located on the upper right portion of the screen,
choose **A1**

using the blue arrows go to 34090 REFP_MOVE_DIST [0]

record the data:

34090 REFP_MOVE_DIST [0]_____

34090 REFP_MOVE_DIST [1]_____

using the + soft key located on the upper right portion of the screen,
choose **B1**

using the blue arrows go to 34090 REFP_MOVE_DIST [0]

record the data:

34090 REFP_MOVE_DIST [0]_____

34090 REFP_MOVE_DIST [1]_____

Repeating the process, record the Backlash amount:

For X1, 32450 BACKLASH[0] _____

For X1, 32450 BACKLASH[1] _____

For Y1, 32450 BACKLASH[0] _____

For Y1, 32450 BACKLASH[1] _____

For Z1, 32450 BACKLASH[0] _____

For Z1, 32450 BACKLASH[1] _____

For A1, 32450 BACKLASH[0] _____

For A1, 32450 BACKLASH[1] _____

For B1, 32450 BACKLASH[0] _____

For B1, 32450 BACKLASH[1] _____

Repeating the process, record the Gain and Band width amount:

a. Press the Drive Data soft key.

b. Go to:

X1 1210 CURRENT_FILTER_1_SUPPR_FREQ _____

X1 1211 CURRENT_FILTER_1_BANDWIDTH _____

X1 1212 CURRENT_FILTER_1_BW_NUM _____

X1 1407 SPEEDCTRL_GAIN1[0] _____

Y1 1210 CURRENT_FILTER_1_SUPPR_FREQ _____

Y1 1211 CURRENT_FILTER_1_BANDWIDTH _____

Y1 1212 CURRENT_FILTER_1_BW_NUM _____

Y1 1407 SPEEDCTRL_GAIN1[0] _____

Z1 1210 CURRENT_FILTER_1_SUPPR_FREQ _____

Z1 1211 CURRENT_FILTER_1_BANDWIDTH _____

Z1 1212 CURRENT_FILTER_1_BW_NUM _____

Z1 1407 SPEEDCTRL_GAIN1[0] _____

A1 1210 CURRENT_FILTER_1_SUPPR_FREQ _____

A1 1211 CURRENT_FILTER_1_BANDWIDTH _____

A1 1212 CURRENT_FILTER_1_BW_NUM _____

A1 1407 SPEEDCTRL_GAIN1[0] _____

B1 1210 CURRENT_FILTER_1_SUPPR_FREQ _____

B1 1211 CURRENT_FILTER_1_BANDWIDTH _____

B1 1212 CURRENT_FILTER_1_BW_NUM _____

B1 1407 SPEEDCTRL_GAIN1[0] _____

4. Set Up Communication Parameters

To back up the machine data to the external computer, prepare the Siemens control for sending data. The following steps sets up the parameters for communication to the external computer.

- a. Press the **SHIFT** and **SYSTEM/ALARM** hard keys simultaneously.
- b. Press the **CNC ISO** soft key, then the **CNC ISO ✓** soft key.
- c. Verify user access level:
 - 1) Press the **SHIFT** and **SYSTEM/ALARM** hard keys simultaneously.
 - 2) Press the **STARTUP** soft key.
 - 3) The message “Actual access level: Manufacturer” should display in the message bar at the bottom of the screen display. If level is not set to Manufacturer or no message displays, continue to step 4. If the level is set to Manufacturer, go to “d.”
 - 4) Press the **SET PASSWORD** soft key.
 - 5) Type **SUNRISE**. The password is set in all UPPERCASE letters. If necessary, press the **SHIFT** hard key while typing the password.
 - 6) Press the **INPUT** hard key. The password field turns orange. Press the **OK** soft key. The message “Password has been set for Manufacturer!” must display on the screen.
- d. Press the **SHIFT** and **SYSTEM/ALARM** hard keys simultaneously.
- e. Press the **SERVICES** soft key.
- f. Press the **DATA OUT** soft key.
- g. Highlight the *Start-up data* line using the up and down arrows.
- h. Press the **RS232 C User** vertical soft key.
- i. Press the **SET** soft key.

At this point, two options columns are displayed (See Figure 2). The left options column is the parameters for communications. The right options column is the “Special Functions.”

The parameters for communications should be as follows:

Interface: COM1
Protocol: RTS/CTS
Baud Rate: 2400 (See note below)
Stop Bits: 1
Parity: none
Data bits: 8
Xon: 11
Xoff: 13
End of Trans: 03

NOTE: On external computers loaded with either the Windows 95 or Windows NT 4.0 operating system, a baud rate of 4800bps or higher may also be used. On external computers loaded with the Windows 98 operating system, setting a baud rate above 2400bps can cause a data transmission failure. In either case, if a transmission failure were to occur, use a baud rate of 2400bps.

“Binary Format (PC form)” should be selected on the second-to-last line in the *Special Functions* column. Also, all the boxes to the left of each line, in the *Special Functions* column, should be clear.

n. Press the **SAVE SETTING** vertical soft key.

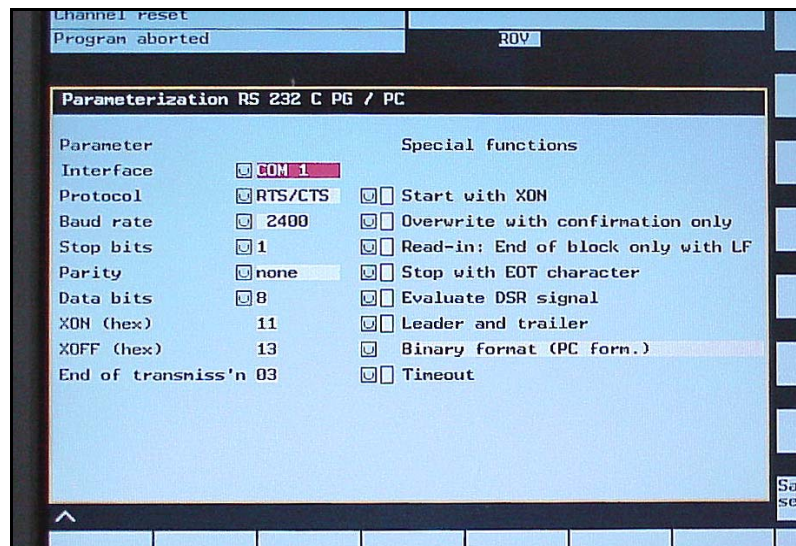

Figure 8 The two options columns used to set the parameters for communication. The *Special functions* column should be cleared.

5. Set Up External Computer

Set up the external computer for receiving data using the PCIN communications program. If applicable, LPT1 must be set to bi-directional in the BIOS.

NOTE: The PCIN communications program is a DOS based program. Therefore, an RTS/CTS error may occur if PCIN is being run in Microsoft Windows. If an error occurs, try turning off power management in Windows, turning off the screen saver, and restarting the computer in DOS mode. If an error still occurs, consult your IT department for further assistance.

- a. Start up the PCIN communications program.
- b. Select V24_INI at the top of the screen (See Figure 3). Press ENTER, two times if necessary, to get the communications parameters box.
- c. Set COM number to “1” or “2” (depending on the COM port communications cable connection at the external computer). Navigate

to the *COM NUMBER* line using the arrow keys. Use the arrow keys to select the proper COM port setting (See Figure 4).

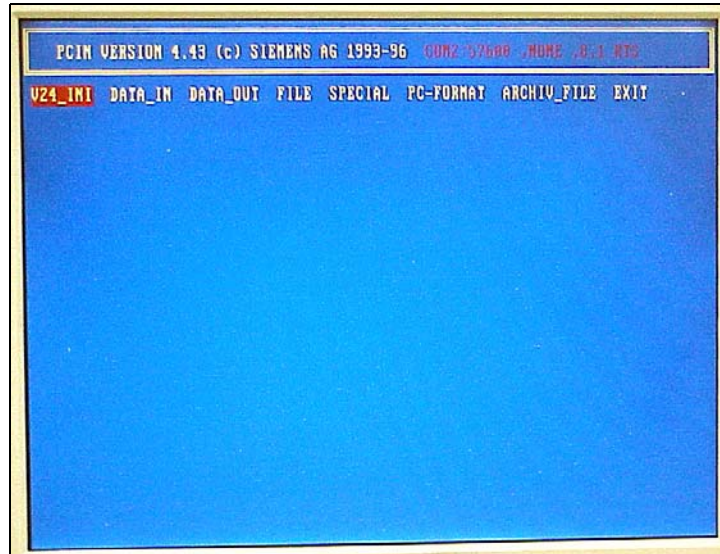

Figure 9 V24_INI selected at the top of PCIN screen display.

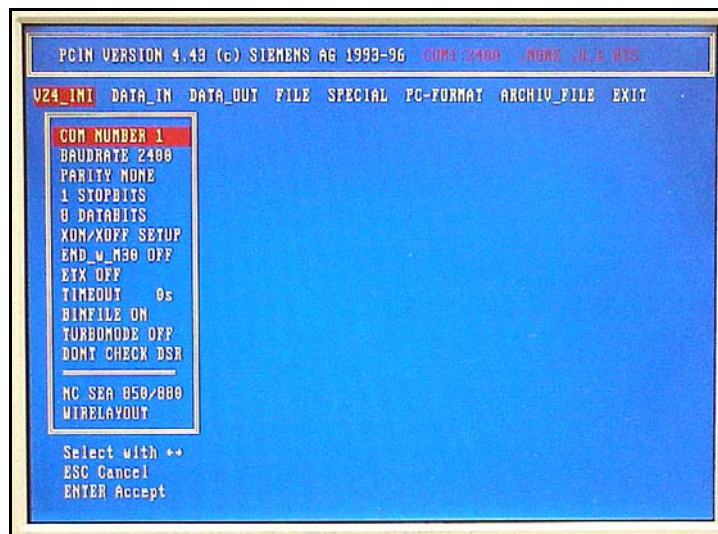

Figure 10 Parameters for communications settings at the external computer. COM NUMBER is set according to the port connection on computer

- d. Set XON/XOFF parameter to "OFF." Use the arrow keys to navigate to the *XON/XOFF SET* line. Use the arrow keys to select *ON* or *OFF* setting in the box that displays (See Figure 5).
- e. Set ETX to "ON."

- f. Press ENTER.
- g. Select yes in the *SAVE INPUT (Y/N)* box that displays.
- h. Select *DATA_IN* at the top of the screen (See Figure 6).

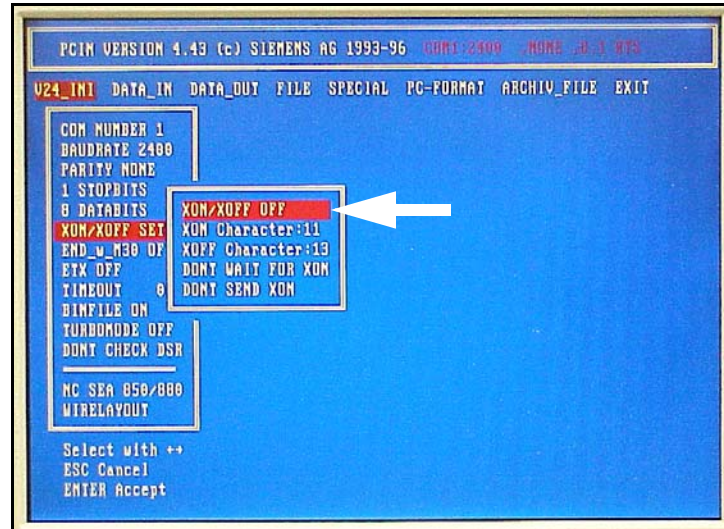

Figure 11 XON/XOFF is set to "OFF."

- i. Press ENTER.

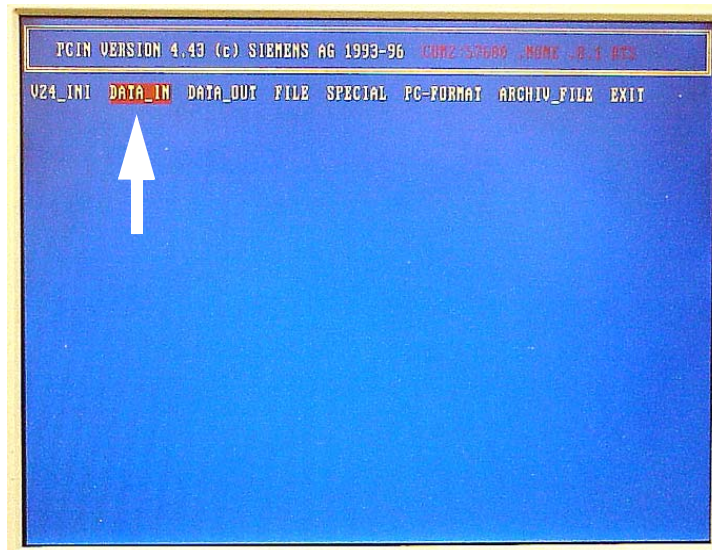

Figure 12 Select *DATA_IN* on the screen display.

- j. Type a filename in the box that appears (create a descriptive filename, for example, *backup.old* or *backup.arc*; see Figure 7). The filename is limited to a maximum of eight characters and the filename extension is limited to a maximum of three characters.

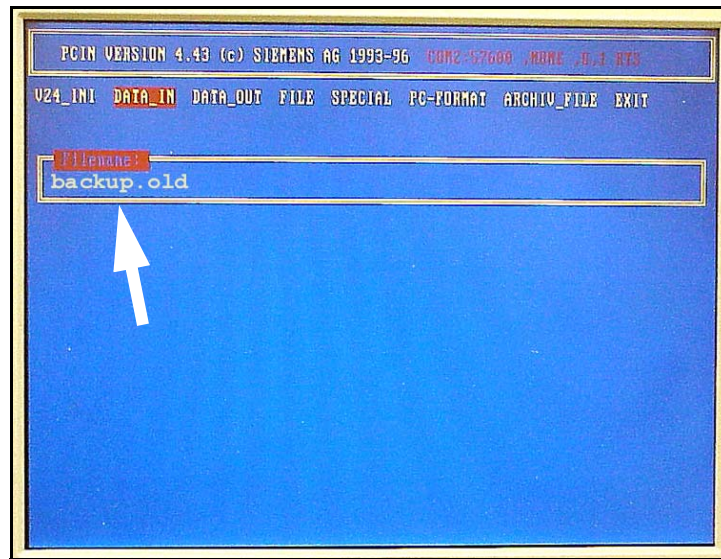

Figure 13 Enter a descriptive filename in the box. The filename is limited to eight characters in length with an extension of three characters.

NOTE: Because the PCIN program is DOS based, filenames and filename extensions are limited to eight characters and three characters, respectively.

- k. Press ENTER
- l. The external computer is now ready to receive the machine data from the Siemens control.

6. Download Startup File

Press the **START** soft key on the control.

The transmission process may stall several times during the data transfer. This is normal. Ignore any tool alarms that may arise. The *Transmission in progress!* window closes when the data transfer is complete. Save the file at the external computer. The entire transfer takes about 15 minutes.

NOTE: The size of the backup file should be 800Kb or larger, depending on the program files loaded into the machine.

To save the file on the external computer:



Press the **ESC** key.

Choose **YES** when asked "Do you want to terminate?"

Choose **YES** when asked "Do you want to save?"

7. Back Up Other Data

Back up all customer programs, tool data, and fixture data. When creating filenames, make sure they are not identical to each other.

- a. Press the SHIFT and SYSTEM/ALARM hard keys simultaneously.
- b. Press the SERVICES soft key.
- c. Press Data out soft key.
- d. Highlight DATA, then press the  INPUT hard key. A sub-list of files display.
- e. Highlight TOOL AND MAGAZINE DATA, then press the  INPUT hard key.
- f. Highlight TOOL DATA.
- g. Press the START soft key.
- h. At the external computer, select DATA_IN at the top of the screen, then press ENTER.
- i. Type a filename in the box that appears (create a descriptive filename, for example, tools1.arc). The filename is limited to a maximum of eight characters and the filename extension is limited to a maximum of three characters.
- j. Press ENTER key. Transmission should automatically start. If it does not, go to the pendant and press the START soft key.
- k. Repeat steps d through j for FIXTURE DATA (ZERO OFFSET). When performing step i, make sure the filename is different from the previous one.
- l. Repeat steps d through j for each customer program. In step d, go to the WORKPIECES and in step e, go to SHOPMILL. Have customer identify their programs, if necessary.



8. "Get" Offset and Backlash Data

This step "gets" the zero offset and backlash data using a `getval_s.mpf` file. This file is referred to as the "get values" program. It reads the zero offsets and the backlash data for all the available axes and displays them one-at-a-time for recording. Before running this program, it must be copied into the *Shopmill* folder, within the *Workpieces* folder, from the Utilities diskette.

Set up the target location for upload

The `getval_s.mpf` file must be loaded into the Shopmill folder. The following steps sets up the pathway to the Shopmill folder.

- a. Press the SHIFT and SYSTEM/ALARM hard keys simultaneously.
- b. Press the SERVICES soft key.

- c. Select *Workpieces*.
- d. Press the  INPUT hard key.
- e. Select *Shopmill*.
- f. Press the  INPUT hard key

Set up communication parameters at control

The following steps sets up the parameters for communication at the control:

- d. Press the RS232 C User vertical soft key.

Press the **SET** soft key.

At this point, two options columns are displayed. The left options column is the parameters for communications. The right options column is the “Special Functions.”

The parameters for communications should be as follows:

Interface: COM1
Protocol: RTS/CTS
Baud Rate: 2400
Stop Bits: 1
Parity: none
Data bits: 8
Xon: 11
Xoff: 13
End of Trans: 03

NOTE: A baud rate of 9600bps or 4800bps may also be used, but at these baud rates there is a greater possibility of a data transmission failure. If this occurs, set the baud rate to 2400bps.

“Binary Format (PC form)” should be selected on the second-to-last line in the *Special Functions* column. Also, all the boxes to the left of each line, in the *Special Functions* column, should be clear.

Press the **SAVE SETTING** vertical soft key.

Verify communication parameter settings at external computer

Check the settings at the external computer for sending data using the PCIN communications program. The settings should not have changed since the last time it was set up. If applicable, the serial port must be set to bi-directional in the BIOS.

NOTE: The PCIN communications program is a DOS based program. Therefore, an RTS/CTS error may occur if PCIN is being run in Microsoft Windows. If an error occurs, try turning off power management in Windows, turning off the screen

saver, and restarting the computer in DOS mode. If an error still occurs, consult your IT department for further assistance.

- a. Start up the PCIN communications program.
- b. Select V24_INI at the top of the screen.
Press ENTER to get the communications parameters box.
- c. The *COM NUMBER* should be set to “1” or “2” (depending on the COM port communications cable connection at the external computer). Navigate to the *COM NUMBER* line using the arrow keys. Use the arrow keys to select the proper COM port setting.
- d. The *XON/XOFF* parameter should be set to “OFF.” Use the arrow keys to navigate to the *XON/XOFF SET* line. Use the arrow keys to select *ON* or *OFF* setting in the box that displays.
- e. Set EXT to “ON.”
- f. Press ENTER.
- g. Select yes in the *SAVE INPUT (Y/N)* box that displays.

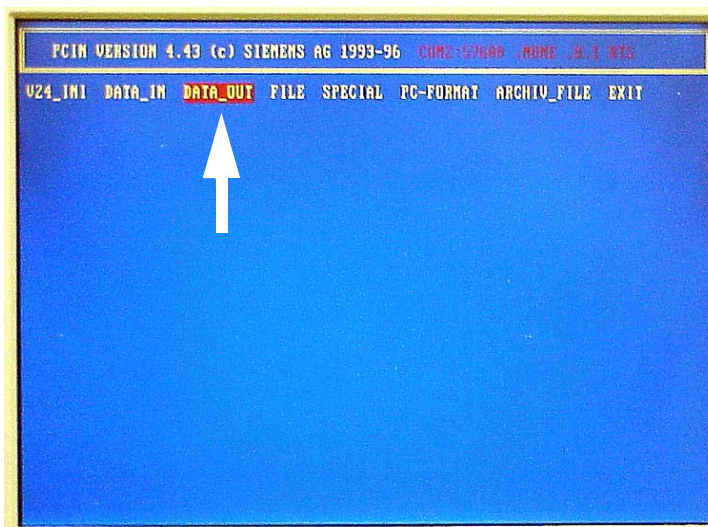





Figure 14 Select DATA_OUT on the screen display.

- h. Select DATA_OUT at the top of the screen (See Figure 8).
- i. Press ENTER.

“Get” Zero Offset and Backlash Data

- a. Insert the utilities diskette into floppy drive of the computer.
- b. Type a: in the *Filename* box.

- c. Press ENTER. The contents of the Utilities diskette displays in the a: directory box.
- d. Select the `getval_s.mpf` file.
- e. Press the ENTER key.
- f. At the pendant, press the START soft key.
- g. Press the OK soft key. The *Transmission in Progress!* window displays.
- h. Press the OK soft key to upload the file. The *Transmission in progress!* window closes when the data transfer is complete.
- i. Press the SHIFT and SYSTEM/ALARM hard keys simultaneously.
- j. Press the PROGRAM soft key.
- k. Select *Shopmill*.
- l. Press the  INPUT hard key.
- m. Select *GET_VALUES*.
- n. Press the *Program selection* soft key.
- o. Press the  AUTO hard key.
- p. Press the  CYCLE START hard key.

Record the information and data that displays near the top part of the display screen (displayed in green text). This is the zero offset (cold start) data for the machine.

- q. Press the  CYCLE START hard key again and write down the next item. This is the axis backlash. Repeat this process for all configured axes. No more data will display when all axes have been accounted for.
- r. Delete the *GET_VALUES* program when all axis offset and backlash data has been collected. Select the *GET_VALUES* program. Press the DELETE soft key. Press the OK soft key.

9. Install New NC Software

The following procedure resets the NCK and loads the new NC operating system.

- a. Power OFF the machine.
- b. Remove the existing NC card from the memory card slot of the CCU interface panel.**
- c. Insert the new NC card into the memory card slot. Figure 9 shows the correct way to insert the NC card.

- d. Set switch S3 to position 1-- NCK general reset (See figure 10 for switch location).
- e. Power ON the machine.
- f. Wait until "b" is displayed on the CCU's 7-segment LED display (H3), then set switch S3 back to 0 (normal operation).

****RETURN THE OLD NC CARD TO FADAL MACHINING CENTERS. THE NEW NC CARD REMAINS WITH THE MACHINE.**

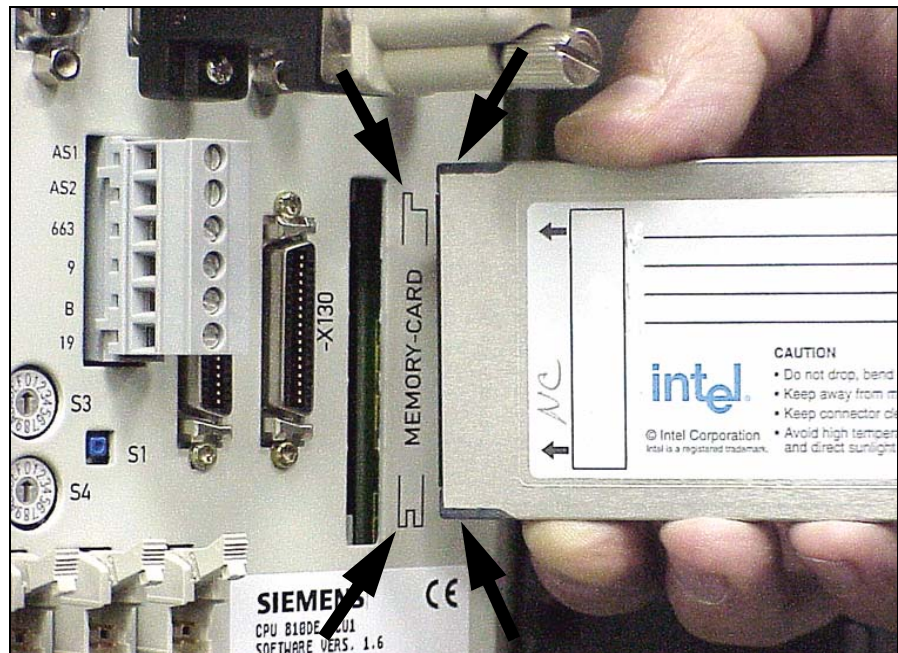

Figure 15 The new NC software is loaded on a PC card. To properly insert the PC card, match the plastic tabs on the end of the card with the diagram printed next to the memory card slot.

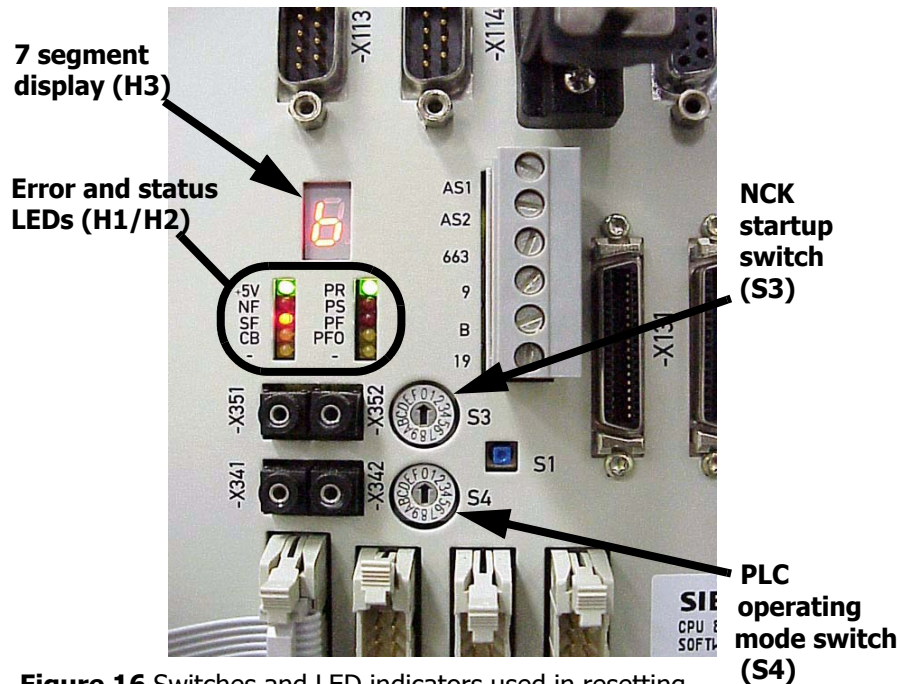

Figure 16 Switches and LED indicators used in resetting the NCK.

When the NCK is reset, all machine data is cleared and a standard machine data set is loaded into memory. The “+5V,” “SF,” and “PR” LEDs are lighted. The 7-segment display shows a “b” (see figure 10).

The following procedure resets the PLC. The overall switching sequence for switch S4 is 2 - 3 - 2 - 3 - 0, as follows:

Set switch **S4** to position 3 (MRES). **LED labeled PS turns off.**

Wait for LED labeled PS to light up again.

Set switch **S4** to position 2 and then back to position 3 within three seconds. LED labeled PS will start flashing.

Wait for LED labeled PS to stop flashing.

Return **S4** to position 0 (PLC-run). The green LED labeled PR will turn on.

The machine is now running the new NC operating system and the old NC/PLC data is erased.

10. Install New HMI firmware

The following procedure updates the display on the pendant. The primary change is the display of updated information verifying the latest version of software installed when the control boots up during power on.

- a. Power the machine OFF.
- b. Locate the cover at the upper right corner of the pendant screen display (see Figure 11).
- c. Open the cover and insert the PC card into the slot.
- d. Power the machine back ON.
- e. Press "6" on the keyboard as soon as the boot-up message appears on screen (This step may require additional assistance).
- f. When the menu appears, select the option *Update from PC card* at the lower left corner of the display. Follow the instructions on screen to install the firmware.



Figure 17 The PC card is inserted into the card slot of the operator panel for the HMI firmware installation.

11. Restore NCK

This step loads the *original.arc* from the NC card into the NCK. These files are standard for all machines. Original.arc contains updated cycle files, GUDs, PLC files, and machine data. The following steps sets up the parameters for communications.

- a. Press **STARTUP** soft key.
- b. Press **SET PASSWORD** soft key
- c. Enter password **SUNRISE** in UPPERCASE letters. If the system is set to lower case letters, depress the **SHIFT** key while entering the password.
- d. Press  **INPUT** hard key. The password field turns orange.
- e. Press **OK** soft key.





- f. The message "Actual access level: Manufacturer!" will display on the screen.
- g. Press the **SHIFT** and **SYSTEM/ALARM** hard keys simultaneously.
- h. Press the **SERVICES** soft key.
- i. Press the  (extended menu) hard key
- j. Press the **Original status** soft key / answer YES to perform series start-up.
- k. Press the **Yes** soft key when asked to overwrite.
Press YES ALL to overwrite any data.
- l. Power OFF and check for basic hardware configuration (see NOTE below).

NOTE: If the machine is equipped with scales and/or 4th/5th axes, the extra hardware **MUST** be disconnected so that the hardware configuration is the same as figures 1 or 2 in the WRG-0002 wiring diagram.



12. Restore the Machine to Its Operational State

This step returns the machine to its operational state with the original zero offsets, backlash, and compensation values.

Power ON and Reference Each Axis

- IF REQUIRED, manually jog each axis to its alignment mark.
 - 1) Press  **MPG** hard key. Wait for LED above the key to illuminate.
 - 2) Select an axis with the axis selector switch.
 - 3) Align the selected axis to its mark by using the handwheel.
 - 4) Repeat steps 2 and 3 for all the axes.
 - 5) Press  **JOG** hard key when done.
- Reference the axes.
 - 1) Select an axis with the axis selector switch.
 - 2) Press  **REF POINT** hard key.
 - 3) Press  (plus) hard key.
 - 4) Repeat steps 1, 2, and 3 for all the axes.
- The axes are referenced when the crosshair symbol  displays to the left of each axis.

Run the Options Program

- a. Press Program Manager hard key.
- b. Press  Pagedown and/or Arrow keys to select OPTIONS (See Figure 12), then press the  INPUT hard key. The program editor window opens.

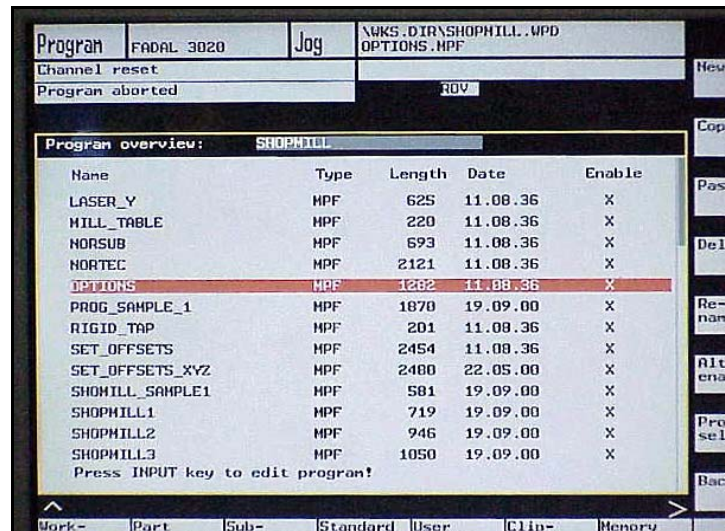

Figure 18 Select the Options folder. Use page down keys and/or arrow keys to navigate to the Options folder.

- c. Find the options table under the “Set Up Options Below” line (See Figure 13). The table lists all the available options for the Siemens control. All the listed options are set equal to zero (0). To enable an option, it must be set equal to one (1).

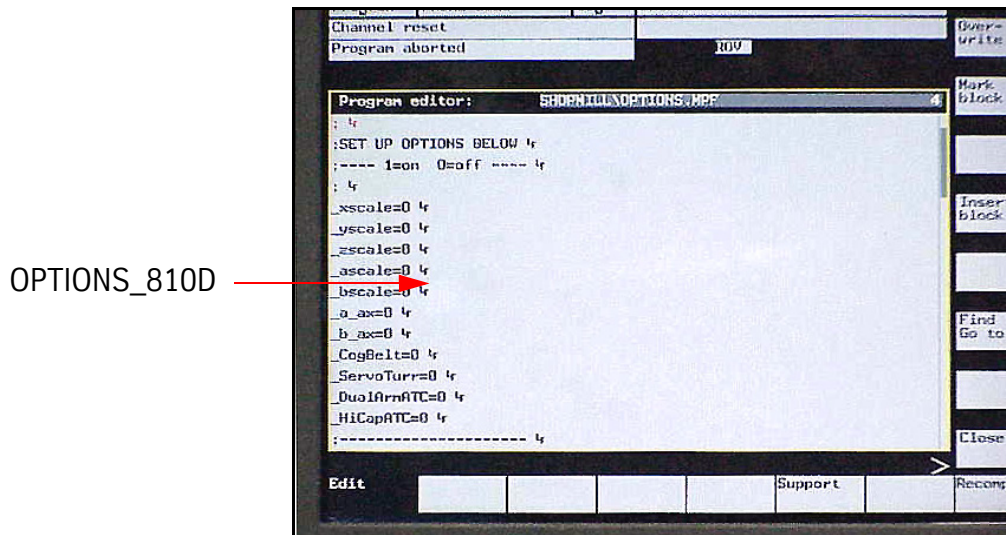

Figure 19 Enable options by changing the options setting to "1" from "0."

- d. Determine the installed options for the machine. Use the diagrams from Appendix A of this manual to identify the installed options.

To identify the installed options, compare the Siemens 810D control in the electronics cabinet, located at the back of the machine, to the options diagrams from Appendix A.

Example: A Siemens machine with an A-axis, X, Y, and Z scales installed will have a setup in the electronics cabinet resembling diagram number "5" (See Figure 14).

Therefore, the settings in the options table will be as follows:

```

_xscale=1
_yscale=1
_zscale=1
_ascale=0
_bscale=0
_a_ax=1
_b_ax=0
_V300=0
_extcolumn=0
_CogBelt=0
_ServoTurr=0

```

```

_DualArmATC=0
_HiCapATC=0
_VHT_Spindle=0
_a1200ipm=0
_m7_is_m8=0
    
```

NOTE: Setting the value to “1” enables the option. For Example, a V300 would require:

```

_a_ax=1
_ascale=1
_V300=1
    
```

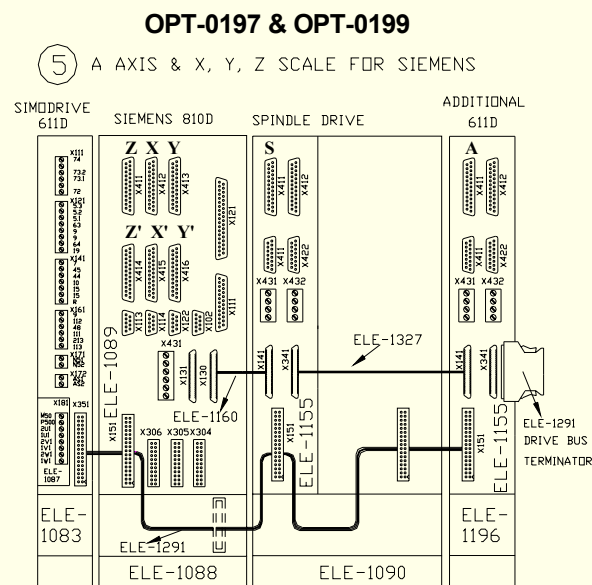



Figure 20 The X', Y', and Z' ports are used for the signal return connection from the scales. A 611D axis extension module is added for machines with 4th and 5th axes.



- e. Go back to the beginning of the program. Use arrow keys to scroll back to the top of the options program. The very first line of text should be displayed in orange when at the beginning of the program. This is important if the program is to be run in its entirety.
- f. Press the Machine from here soft key.

- g. Press the  CYCLE START hard key.
- h. The *Power off* message displays at the bottom of the screen display when the program finishes running.
- i. Power the machine OFF.
- j. Reconnect optional hardware as needed.
- k. Power ON and reference the axes.

Set up Tool Magazine

- a. Press the JOG hard key.
- b. Press the MDA soft key.
- c. Type **TC_BASE**
M2
- d. Press the CYCLE START key.
- e. Wait until the “WAIT” message disappears.

Set up Communication Parameters at the Control

- a. Press the SHIFT and SYSTEM/ALARM hard keys simultaneously.
- b. Press the CNC ISO soft key, then press the CNC ISO ✓ soft key.
- c. Verify user access level:
 - 1) Press the SHIFT and SYSTEM/ALARM hard keys simultaneously.
 - 2) Press the STARTUP soft key.
 - 3) The message “Actual access level: Manufacturer” should display in the message bar at the bottom of the screen display. If level is not set to Manufacturer or no message displays, continue to step 4. If the level is set to Manufacturer, go to “d.”
 - 4) Press the SET PASSWORD soft key.
 - 5) Type SUNRISE. The password is set in all UPPERCASE letters. If necessary, press the SHIFT hard key while typing the password.
 - 6) Press the  INPUT hard key. The password field turns orange. Press the OK soft key. The message “Password has been set for Manufacturer!” must display on the screen.
- d. Press the SHIFT and SYSTEM/ALARM hard keys simultaneously. Press the SERVICES soft key.
- e. Select *Workpieces*.
- f. Press the  INPUT hard key.

- g. Select *Shopmill*.
- h. Press the  INPUT hard key
- i. Press the RS232 C User vertical soft key.
- j. Press the SET soft key.

At this point, two options columns are displayed. The left options column is the parameters for communications. The right options column is the “Special Functions.”

The parameters for communications should be as follows:

Interface: COM1
Protocol: RTS/CTS
Baud Rate: 2400 (See note below)
Stop Bits: 1
Parity: none
Data bits: 8
Xon: 11
Xoff: 13
End of Trans: 03

NOTE: On external computers loaded with either the Windows 95 or Windows NT 4.0 operating system, a baud rate of 4800bps or higher may also be used. On external computers loaded with the Windows 98 operating system, setting a baud rate above 2400bps can cause a data transmission failure. In either case, if a transmission failure were to occur, use a baud rate to 2400bps.

“Binary Format (PC form)” should be selected on the second-to-last line in the *Special Functions* column. Also, all the boxes to the left of each line, in the *Special Functions* column, should be clear.

- k. Press the SAVE SETTING vertical soft key.

Set up Communication Parameters at External Computer

Set up the external computer for sending data using the PCIN communications program. If applicable, the serial port must be set to bi-directional in the BIOS.



NOTE: The PCIN communications program is a DOS based program. Therefore, an RTS/CTS error may occur if PCIN is being run in Microsoft Windows. If an error occurs, try turning off power management in Windows, turning off the screen saver, and restarting the computer in DOS mode. If an error still occurs, consult your IT department for further assistance.

- a. Start up the PCIN communications program.
- b. Select V24_INI at the top of the screen (see Figure 3).
Press ENTER to get the communications parameters box.

- c. Set COM number to “1” or “2” (depending on the COM port communications cable connection at the external computer). Navigate to the *COM NUMBER* line using the arrow keys. Use the arrow keys to select the proper COM port setting
- d. Set XON/XOFF parameter to “OFF.” Use the arrow keys to navigate to the *XON/XOFF SET* line. Use the arrow keys to select *ON* or *OFF* setting in the box that displays.
- e. Set EXT to “ON.”
- f. Press ENTER.
- g. Select *yes* in the *SAVE INPUT (Y/N)* box that displays.
- h. Select *DATA_OUT* at the top of the screen.
- i. Press ENTER





“Set” Zero Offset and Backlash Data

Restoring zero offsets and backlash for each axis is done with the *SET_VALUES* program. This program needs to be uploaded from the Utilities diskette to the control. At that point, the program will be used to automatically restore the original zero offset and backlash data.

- a. Insert the Utilities diskette into floppy drive of the computer.
- b. Type *a:* in the *Filename* box and press ENTER. The contents of the Utilities diskette displays in the *a:* directory box.
- c. Select the *setval_s.mpf* file.
- d. Press the ENTER key.
- e. At the pendant, press the **START** soft key.
- f. Press the **OK** soft key. The *Transmission in Progress!* window displays.
- g. Press the **OK** soft key to upload the file. The *Transmission in progress!* window closes when the data transfer is complete.
- h. Select *Shopmill*.
- i. Press the  INPUT hard key.
- j. Select *SET_VALUES*.
- k. Press the  INPUT hard key. This opens the editor window for the *SET_VALUES* program.

CAUTION: When working in this editor window, be careful not to alter any data other than the data in the table. Altering any other data may prevent the program from running properly.

- l. Press the  Page down hard key to get to the table.

- m. Take the zero offset and backlash information that was written down on paper earlier. Enter these values into their respective lines in the table. When done, close the editor window. Press the **Close** soft key.
- n. Press the **SHIFT** and **SYSTEM/ALARM** hard keys simultaneously.
- o. Press the **Program** soft key.
- p. Select **Shopmill** and press the  **INPUT** hard key.
- q. Select **SET_VALUES** and press the **Program selection** soft key.
- r. Press the  **Auto** hard key.
- s. Press the  **CYCLE START** hard key. A message should display near the top of screen display. The message identifies the zero offset or backlash data that has been entered.
- t. Press the  **CYCLE START** hard key repeatedly until all the zero offset and backlash data has been entered for all the configured axes.
- u. Delete the **SET_VALUES** program when all axis offset and backlash data has been entered. Select the **SET_VALUES** program. Press the **DELETE** soft key. Press the **OK** soft key.

Restore Tool and Magazine Data

Restore Work Offset Data. (Send back files created in Step #7-Back Up Other Data.) Record turret number. It is located above the pocket ready for tool exchange.

Restore Magazine Count

1. Press **E-STOP**.
2. Go to **ISO**.
3. Press the **SHIFT** and **SYSTEM** keys at the same time.
4. Press the **DIAGNOSTICS** soft key.
5. Press the **PLC** soft key.
6. Type **C5** in the first column.
7. Press the **INPUT** key. The cursor will jump to the second column.
8. Type **D**.
9. Press the **INPUT** key.
10. Type **DB92.DBW0**
11. Press the **INPUT** key.
12. Type **D**.

13. Press the INPUT key.
14. Press the CHANGE vertical soft key.
15. Enter the number of the tool pocket in front of the spindle in the field for both operands. (C5 and DB92.DBW0)
16. Press the ACCEPT vertical soft key.
17. Release the E-STOP button and press RESET.

Restore Gain Settings

- a. Press Menu Select hard key.
- b. Select Start-up soft key.
- c. Wait for Startup screen to load.
- d. Press **Machine data**
- e. Press **Axis specific**
- f. go to the following machine data and type in the data from step 3
 - using the + soft key located on the upper right portion of the screen, choose **X1** using the blue arrows go to 34090 REFP_MOVE_DIST [0] type in data, then go to 34090 REFP_MOVE_DIST [1] and type in data
 - using the + soft key located on the upper right portion of the screen, choose **Y1** using the blue arrows go to 34090 REFP_MOVE_DIST [0] type in data, then go to 34090 REFP_MOVE_DIST [1] and type in data
 - using the + soft key located on the upper right portion of the screen, choose **Z1** using the blue arrows go to 34090 REFP_MOVE_DIST [0] type in data, then go to 34090 REFP_MOVE_DIST [1] and type in data
 - using the + soft key located on the upper right portion of the screen, choose **A1** using the blue arrows go to 34090 REFP_MOVE_DIST [0] type in data, then go to 34090 REFP_MOVE_DIST [1] and type in data
 - using the + soft key located on the upper right portion of the screen, choose **B1** using the blue arrows go to 34090 REFP_MOVE_DIST [0] type in data, then go to 34090 REFP_MOVE_DIST [1] and type in data

Repeat the process for the Backlash amount:

- X1 32450 BACKLASH[0] type in data
- X1 32450 BACKLASH[1] type in data
- Y1 32450 BACKLASH[0] type in data
- Y1 32450 BACKLASH[1] type in data
- Z1 32450 BACKLASH[0] type in data
- Z1 32450 BACKLASH[1] type in data

A1 32450 BACKLASH[0] type in data

A1 32450 BACKLASH[1] type in data

B1 32450 BACKLASH[0] type in data

B1 32450 BACKLASH[1] type in data

Repeating the process record the Gain and Band width amount.

Press the FDD soft key.

X1 1210 _____

X1 1211 _____

X1 1212 _____

X1 1407 [0] _____

Y1 1210 _____

Y1 1211 _____

Y1 1212 _____

Y1 1407 [0] _____

Z1 1210 _____

Z1 1211 _____

Z1 1212 _____

Z1 1407 [0] _____

A1 1210 _____

A1 1211 _____

A1 1212 _____

A1 1407 [0] _____

B1 1210 _____

B1 1211 _____

B1 1212 _____

B1 1407 [0] _____

1. Press the BOOT FILE vertical soft key.
2. Press the SAVE BOOT FILE vertical soft key.

3. Press the SAVE ALL vertical soft key.

- Reference the axes.
 - a. Press the Machine hard key.
 - b. Select an axis with the axis selector switch.
 - c. Press REF POINT hard key.
 - d. Press (plus) hard key.
 - e. Repeat steps 2, 3, and 4 for all the axes.

- The axes are referenced when the crosshair symbol displays to the left of each axis. Position will be restored to factory setting.

Load Compensation Values

- a. Open program COMP_VALUES_n (*n* is the axis in question). The Comp Values survey sheet is located in electronics cabinet on the backside of the machine. *There is no need to enter any comp values if they already exist.*
- b. Press PROGRAM MANAGER hard key
- c. Use up and down arrow keys to select the desired axis program.
- d. Press INPUT hard key to open the program and edit values.
- e. Go to the start of the program using PAGE UP hard key.
- f. Press MACHINE FROM HERE soft key to load the program.
- g. Press CYCLE START. The program will load the compensation values into memory.
- h. Repeat this steps *a* through *g* for all the axes being compensated.
- i. Press the SHIFT and SYSTEM/ALARM hard keys simultaneously.
- j. Press the Machine manual soft key.
- k. Press the MDA soft key.
- l. Press the Delete soft key. This deletes all the contents in the buffer.
- m. Type M83
Press the CYCLE START hard key.

NOTE: M83 displays the value in degrees of the measurement just performed. M83 should be run as many times as needed until the value displayed is the same twice (a minimum of two times), +/- one degree.

Wait for the control to display the alarm "*POWER ON.*"
Power the machine OFF and back ON.
Reference (cold start) the axes.

- n. Type **M83**, again.
Press the **CYCLE START** hard key.
Wait for the control to display the alarm "**POWER ON.**"
Power the machine OFF and back ON.
Reference (cold start) the axes.
- o. While still in MDA mode, type **M84**
Press **CYCLE START** hard key.
Wait for the control to display the "**MEASUREMENT COMPLETED**" on the lower part of the display.
- p. Power the machine off and then back on.
- q. Reload all customer programs and any customized data back into NCK.

13. Create New Back-up File

Create a back-up file for the updated system software.

- Set up the communication parameters at the machine.
 - a. Press the **SHIFT** and **SYSTEM/ALARM** hard keys simultaneously.
 - b. Press the **CNC ISO** soft key and then press the **CNC ISO** ✓ soft key.
 - c. Verify password is set to *Manufacturer*.
 - d. Press the **SHIFT** and **SYSTEM/ALARM** hard keys simultaneously.
 - e. Press the **SERVICES** soft key.
 - f. Press the **DATA OUT** soft key.
 - g. Highlight the *Start-up data* line using the up and down arrows.
 - h. Press the **RS232 C User** vertical soft key.
 - i. Press the **SET** soft key.
At this point, two options columns are displayed. The left options column is the parameters for communications. The right options column is the "Special Functions."
 - j. Set the parameters for communications.

Interface: COM1
Protocol: RTS/CTS
Baud Rate: 2400 baud (See note below)
Stop Bits: 1
Parity: none
Data bits: 8
Xon: 11
Xoff: 13
End of Trans: 03

NOTE: On external computers loaded with either the Windows 95 or Windows NT 4.0 operating system, a baud rate of 4800bps or higher may also be used. On external computers loaded with the Windows 98 operating system, setting a baud rate above 2400bps can cause a data transmission failure. In either case, if a transmission failure were to occur, use a baud rate to 2400bps.

“Binary Format (PC form)” should be selected on the second-to-last line in the *Special Functions* column. Also, all the boxes to the left of each line, in the *Special Functions* column, should be clear.

k. Press the **SAVE SETTING** vertical soft key.

- Set up the communication parameters on the external computer.
 - a. Start up the PCIN communications program.
 - b. Select **V24_INI** at the top of the screen and press **ENTER** to get the communications parameters box.
 - c. Set COM number to “1” or “2” (depending on the COM port communications cable connection at the external computer). Navigate to the *COM NUMBER* line using the arrow keys. Use the arrow keys to select the proper COM port setting.
 - d. Set XON/XOFF parameter to “OFF.” Use the arrow keys to navigate to the *XON/XOFF SET* line. Use the arrow keys to select *ON* or *OFF* setting in the box that displays
 - e. Press **ENTER**.
 - f. Select *yes* in the *SAVE INPUT (Y/N)* box that displays.
 - g. Select **DATA_IN** at the top of the screen. Press **ENTER**.
 - h. Type a filename in the box that appears. The filename is limited to a maximum of eight characters and the filename extension is limited to a maximum of three characters.
 - i. Set EXT to “ON.”
 - j. Press **ENTER**
 - k. The external computer is now ready to receive the machine data from the Siemens control.

- Download the new system files to the external computer.

a. Press the **START** soft key on the control.

NOTE: The transmission process may stall several times during the data transfer. This is normal. Ignore any tool alarms that may arise. The *Transmission in progress!* window closes when the data transfer is complete. Save the file at the external computer.

b. To save the file on the external computer:

Press the ESC key.

Choose *YES* when asked “Do you want to terminate?”

Choose *YES* when asked “Do you want to save?”

Make two (2) copies of the new NC/PLC system files. Use the PCIN program to copy the files onto floppy diskettes. Store one with the machine. On the second copy, WRITE THE SERIAL NUMBER OF THE MACHINE ON THE DISKETTE; THEN SEND IT TO FADAL MACHINING CENTERS.

NOTE: DO NOT open this file! Opening it will damage the header! The icon may appear to be a zip file, but it is only a Siemens archive file.

DATC Hardware Update 1.7.2 (or above)

IMPORTANT! MMC100 DATC Software Update **MUST BE INSTALLED FIRST.**

General Information

Check the existing Siemens hardware before proceeding with this update. Compare the hardware to WRG-0002 REV F (see Appendix A). If the ports and cables are found to be a different configuration, then order the replacement part(s) and install prior to proceeding with this update.

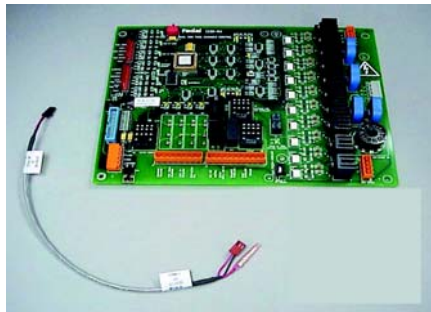

Figure 21 PCB-0230 and 2010-1/J3 to 1100-1/J3 Cable.

Tools Required

The components required are as follows:

PCB-0230 PCB, DATC CONTROLLER;
SIEMENS 1330 (includes PLC Chip for 1330 card; **must be Siemens Version 2.02**)

Cable, 2010-1/J3 to 1100-1/J3

For information on Cable setup, see the wiring diagram at the end of this manual.

1. Replace Hardware for DATC

- a. Turn the main power off.
- b. Replace existing 1330-0A DATC Controller with new PCB-0230 1330-0A. Make sure that the PLC Chip is Siemens Version 2.02.
- c. If necessary, attach Cable 2010-1/J3 to 1100-1/J3. If the cable is missing, and if a single wire currently exists at 1100-1/J3 connecting to 1980-0 or 2000-0 or 2030-0 board, then cut the connector off of the existing wire, insert it into a new cable at the butt splice on the red wire and crimp. Then install the new cable.
- d. Repackage the removed components and return them to Fadal with a PCR form for each part for credit.

MMC103 Software Update v1.7.2 (or above)

IMPORTANT! If the VMC is equipped with a DATC please see page 69.

NOTE: You **must** install an updated software version and DATC hardware if no hardware is present.

General Information

Before performing this software update, READ THROUGH THE PROCEDURE AT LEAST ONE TIME, COMPLETELY. This will ensure a more effective error-free update. Also verify the configuration of the Siemens control using WRG-0002 REV F (see Appendix A).

It is important that a COMPLETE BACK-UP is made of the current machine data before performing software update. If an error is made in the software update of the machine data, the back-up file can be used to restore the system to its original configuration.

Part number information for the Software Update Kit and its components can be found in Appendix B of this manual.

List of Components

- NC card containing original.arc file and nck.abb operating system
- A pre-imaged hard drive (MMC103 only)
- Utilities disk

The hmi.abb and nck.abb files are required for updating the display. These files are stored on PC cards. The hmi.abb file contains the necessary firmware for the display. The nck.abb file is the system software that resides on an NC card (PCMCIA).

The pre-imaged hard drive replaces the existing hard drive on the MMC103 module. The pre-imaged hard drive contains software tools that are used to restore the machine.



Figure 22 The files for performing the MMC103 software update are stored on a PC card and Utilities disk. The pre-imaged hard drive replaces the existing one in the MMC103 module.

Tools Required

MMC103

- An external computer, either a laptop computer or desktop PC (personal computer). The external computer hard disk is used to store the backup files from the 810D control.
- The PCIN communications program, supplied by Fadal, installed on the external computer.
- A 9-pin to 9-pin RTS/CTS 5-wire null modem serial communications cable

MMC103 Update Procedure

The overview of this update procedure is as follows:

1. Save tool data, zero offsets, and backlash.
2. Back up existing (original) machine data.
3. Install new NC operating system.
4. Reset PLC.
5. Load new **original.arc** file from flashcard.
6. Restore machine to its operational state.
7. Reload customer data.
8. Edit and run Options program.
9. Enter and run compensation values for all axes.
10. Replace old hard disk drive unit with new pre-imaged hard disk drive unit.
11. Create backup of new machine data. One backup will be copied to the Archive folder. The other backup will be copied onto a 3.5 inch diskette and sent to Fadal Machining Centers.

This software update procedure starts from power-on.

1. Preparation for Software Update

- a. Call tool zero (0) [T0, M6].
- b. Save tool data
- c. Unload tools from tool changer.





2. Power On

Power on the machine. Booting up the MMC103 will take several minutes.





Reference the axes

Each axis on the machine must be referenced before performing the update. Referencing can be done while in Shopmill or in ISO. The default, when the control boots up, is Shopmill. If referencing the axes in ISO mode is desired, it can be done following step *d* in "[Go To ISO Mode.](#)"

- a. Select an axis with Axis Selector switch located on the MPG.

- b. Press  Ref Point hard key.
- c. Press  “plus” hard key. The selected axis is referenced when the crosshair symbol  appears.
- d. Select the next axis and press the  “plus” hard key. Repeat this step until all configured axes have been referenced.



Go To ISO Mode

- a. Press  Menu Select hard key.
- b. Press CNC ISO soft key, then press CNC ISO ✓ soft key.
- c. Wait for ISO screen to load.
- d. Press  Menu Select hard key.
- e. Press Start-up soft key.
- f. Wait for Startup screen to load.
- g. Press Password... soft key.
- h. Press Set Password soft key.
- i. Enter the password SUNRISE in all UPPERCASE lettering. To type in uppercase, press and hold  SHIFT hard key while typing the password.
- j. Press  INPUT (yellow) hard key. The message “*Password has been set for manufacturer*” will display in the lower part of the screen. If the password has been typed incorrectly, the message “*Password is not valid!*” will display. Press the OK soft key and re-enter password.

3. “Get” Offset and Backlash Data

This step “gets” the zero offset and backlash data using a `getval_s.mpf` file. This file is referred to as the “get values” program. It reads the zero offsets and the backlash data for all the available axes and displays them one-at-a-time for the user to write down. Before running this program, it must be copied into the *Shopmill* folder, within the *Workpieces* folder, from the Utilities diskette.

- a. Press  Menu Select hard key.
- b. Press Services soft key.

- c. Highlight the *Workpieces* folder. Using the arrow keys, move the blue bar until the *Workpieces* folder is highlighted.
- d. Press  INPUT hard key.
- e. Highlight the *Shopmill* folder. Using the arrow keys, move the blue bar to highlight the *Shopmill* folder.
- f. Press **Data** in soft key.
- g. Press **Disk...** soft key. Insert the Utilities diskette when prompted to do so.
- h. Press **OK** soft key. An overlay box appears displaying the contents of the Utilities diskette.
- i. Highlight the *getval_s.mpf* file. Select the file by highlighting it with the blue bar.
- j. Press **Start** soft key. When the *getval_s.mpf* file is copied into the *Shopmill* folder, the overlay box closes and the message “Job is ready” displays at the bottom of the screen.
- k. Highlight the *Shopmill* folder and press the  INPUT hard key. The contents of the folder will display. Find the file named *GET_VALUE*. This is the *getval_s.mpf* program.
- l. Press **Manage data** soft key.
- m. Press **Load** vertical soft key. This loads the get value program. An “X” displays in the *loaded* column (See Figure 15).

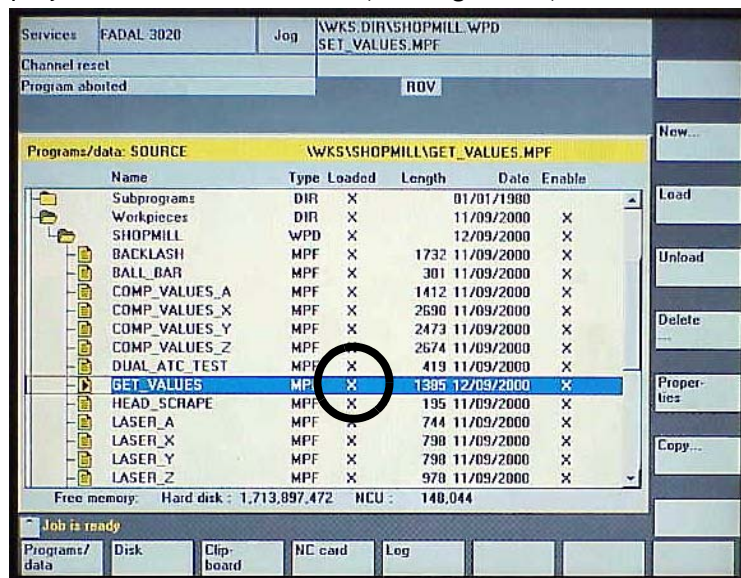





Figure 23 An X in the “loaded” column indicates SET_VALUES program is loaded.

- n. Press  Menu Select hard key.
- o. Press Program soft key.
- p. Highlight the *Shopmill* folder and press the  INPUT hard key. The contents of the Shopmill folder displays.
- q. Highlight the *GET_VALUES* file.
- r. Press the Select vertical soft key.
- s. Press  Auto hard key.
- t. Press  Cycle start hard key (green).
- u. Write down, on paper, the information and data that displays near the top part of the display screen (See Figure 16). This is the zero offset and backlash data for the machine.

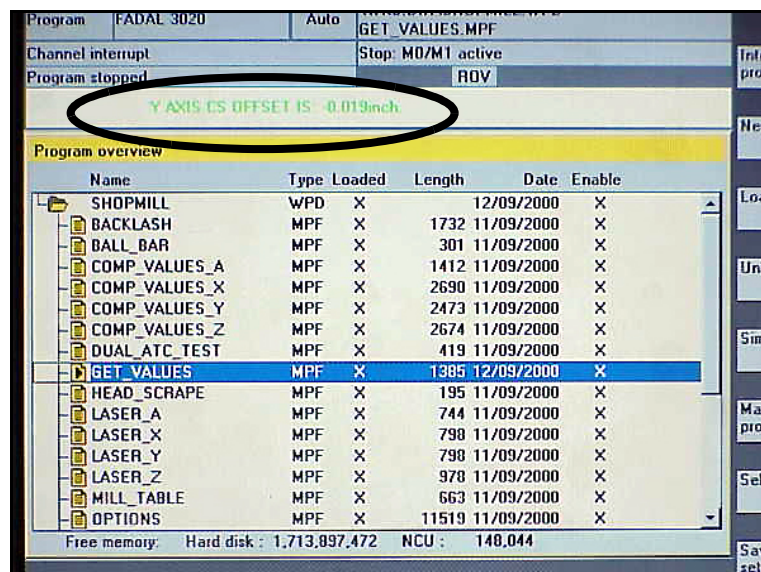



Figure 24 Record the axis data for zero offsets and backlash when the data displays at the top of the screen.



- v. Repeat steps t and u for all the available axes. No more data displays when all the axes have been checked.
- w. Press Manage programs vertical soft key.
- x. Highlight the *GET_VALUES* file.
- y. Press Delete... soft key. This deletes the GET VALUES file. This file is a utilities program used specifically for getting the machine data for this software update. Therefore, it should not be left in the system.
- z. Press Yes soft key.

4. Back Up Tool Data and Zero Offsets

Spindle tool data is lost during power up. The following procedure will save spindle tool data.

- a. Press  Menu Select hard key.
- b. Press **Services** soft key.
- d. Press **Data Out** soft key. IF the **Data Out** soft key is not displayed, press  (extended menu) hard key to display the **Data Out** soft key.
- e. Select the *NC-active-data* folder. Use either the arrow hard keys or the page down hard key to navigate to the folder, if needed. Folder is selected when it is highlighted [in blue].





NOTE: If this folder is not visible, press the data selection soft key. Then use the up or down arrows until the folder is highlighted. Then press the O.K. soft key.

- f. Press  **INPUT** hard key. A list of subfolders will display.
- g. Select the *Tool/magazine-data* folder. The folder is selected when it is highlighted in blue.
- h. Press  **INPUT** hard key. Another list of subfolders will display.
- i. Select the *Tool-offsets* folder. The folder is selected when it is highlighted in blue.
- j. Press **Archive...** soft key.
- k. Use the default name, **TO_TOA**, or enter a descriptive filename, in the *Archive* field at the bottom of the screen, for the tool offsets data folder being created.
- l. In the *Arch* field, verify that *Binary format (PC form.)* is selected.
- m. Press **Start** soft key.
- n. Press the **YES** soft key if a message in the *Query* box displays asking to overwrite.
- o. Select the *Zero-offsets* folder. Navigate to the folder by using the arrow hard keys.
- p. Press **Archive...** soft key.
- q. Use the default name, **UFR**, or enter a descriptive filename, in the *Archive* field at the bottom of the screen, for the zero offsets data folder being created.
- r. In the *Arch* field, verify that *Binary format (PC form.)* is selected.

- s. Press **Start** soft key.
- t. Press the **YES** soft key if a message in the *Query* box displays asking to overwrite.

5. Back Up Original Machine Data

The following procedure creates a backup of all machine data to the MMC103 hard drive.

- a. Press  **Menu Select** hard key.
- b. Press **Services** soft key.
- c. Select the *Archive* folder. The arrow hard keys may be used to navigate to the *Archive* folder.
- d. Press **Data Out** soft key.
- e. Press  (extended menu) hard key.
- f. Press **Series start-up** soft key.
- g. Under *Archive contents*, remove the *X* from the *MMC* box and put an *X* in the *With compensation data* box. Use the **SELECT**  hard key to enter and remove the *X*. Only the *NC*, *PLC*, and *With compensation data* boxes should be selected.
- h. In the *Archive name* field, type the filename **OLDNCPLC** for the backup file.
- i. Press  **INPUT** hard key.
- j. Press **Archive** soft key.
- k. If a message in the *Query* box displays a question about overwriting, select **YES**.

The process will take approximately 15 minutes. The “job is ready” message will display at the bottom of the screen when the backup is complete.

During the backup process, several **ERROR** messages will display. Ignore these messages.

The total file size should be 800Kb or larger. If file size is smaller than 870Kb, then this procedure must be repeated. To verify the file size, perform the following steps.

- a. Press  **Menu Select** hard key.

- b. Press **Services** soft key.
- c. Press **Disk** soft key. This displays the contents of the disk.
- d. Find the **OLDNCPLC** file. Verify the file size under the *length* column.63. Recording Original Cold Start Position, Backlash Data and Gain Settings

- a. Press **MENU SELECT** hard key.
- b. Select **START-UP** soft key.
- c. Wait for Startup screen to load.
- d. Press **Machine data**

e. Press **Axis specific**

- f. Go to machine data for each axis and record the following using the + soft key located on the upper right portion of the screen, choose **X1**

using the blue arrows goto 34090 REFP_MOVE_DIST [0]

Record this data:

34090 REFP_MOVE_DIST [0]_____

34090 REFP_MOVE_DIST [1]_____

using the + soft key located on the upper right portion of the screen, choose **Y1**

using the blue arrows go to 34090 REFP_MOVE_DIST [0]

record this data here:

34090 REFP_MOVE_DIST [0]_____

34090 REFP_MOVE_DIST [1]_____

using the + soft key located on the upper right portion of the screen, choose **Z1**

using the blue arrows go to 34090 REFP_MOVE_DIST [0]

record this data here:

34090 REFP_MOVE_DIST [0]_____

34090 REFP_MOVE_DIST [1]_____

using the + soft key located on the upper right portion of the screen, choose **A1**

using the blue arrows go to 34090 REFP_MOVE_DIST [0]

record this data here:

34090 REFP_MOVE_DIST [0] _____

34090 REFP_MOVE_DIST [1] _____

using the + soft key located on the upper right portion of the screen,
choose **B1**

using the blue arrows go to 34090 REFP_MOVE_DIST [0]

record this data here:

34090 REFP_MOVE_DIST [0] _____

34090 REFP_MOVE_DIST [1] _____

Repeating the process, record the Backlash amount:

For X1, 32450 BACKLASH[0] _____

For X1, 32450 BACKLASH[1] _____

For Y1, 32450 BACKLASH[0] _____

For Y1, 32450 BACKLASH[1] _____

For Z1, 32450 BACKLASH[0] _____

For Z1, 32450 BACKLASH[1] _____

For A1, 32450 BACKLASH[0] _____

For A1, 32450 BACKLASH[1] _____

For B1, 32450 BACKLASH[0] _____

For B1, 32450 BACKLASH[1] _____

Repeating the process, record the Gain and Band width amount:

1. Press the DRIVE MD soft key.

2. Go to:

X1 1210 _____

X1 1211 _____

X1 1212 _____

X1 1407 [0] _____

Y1 1210 _____

Y1 1211 _____

Y1 1212 _____
 Y1 1407 [0] _____

Z1 1210 _____
 Z1 1211 _____
 Z1 1212 _____
 Z1 1407 [0] _____

A1 1210 _____
 A1 1211 _____
 A1 1212 _____
 A1 1407 [0] _____

B1 1210 _____
 B1 1211 _____
 B1 1212 _____
 B1 1407 [0] _____

6. Install New NC Software

The following procedure resets the NCK and loads the new NC software.

- a. Power off the machine.
- b. Remove the existing NC card from the memory card slot of the CCU interface panel.**
- c. Insert the new NC card into the memory card slot. Figure 17 shows the correct way to insert the NC card.
- d. Set switch S3 to position 1-- NCK general reset (See Figure 18 for switch location).
- e. Power on the machine.
- f. Wait until "6" is displayed on the CCU's 7-segment LED display (H3), then set switch S3 back to 0 (normal operation).

**RETURN THE OLD NC CARD TO FADAL MACHINING CENTERS. THE NEW NC CARD REMAINS WITH THE MACHINE.

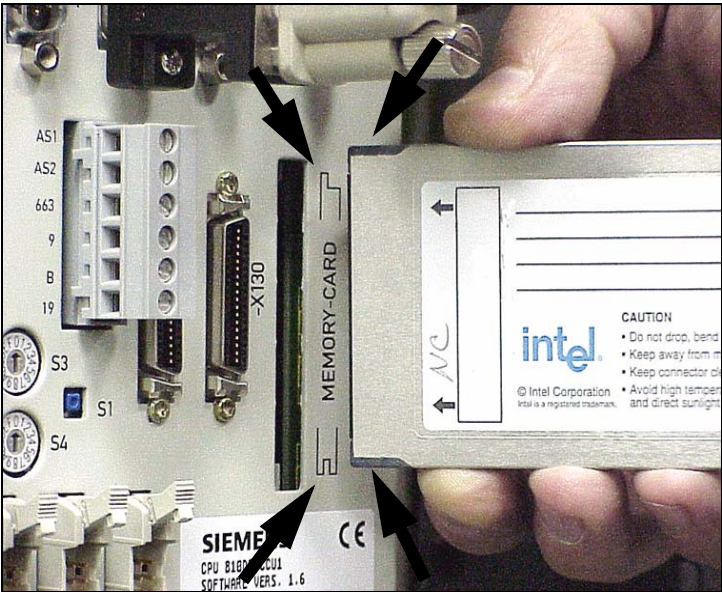

Figure 25 The new NC software is loaded on a PC card. To properly insert the PC card, match the plastic tabs on the end of the card with the diagram printed next to the memory card slot.

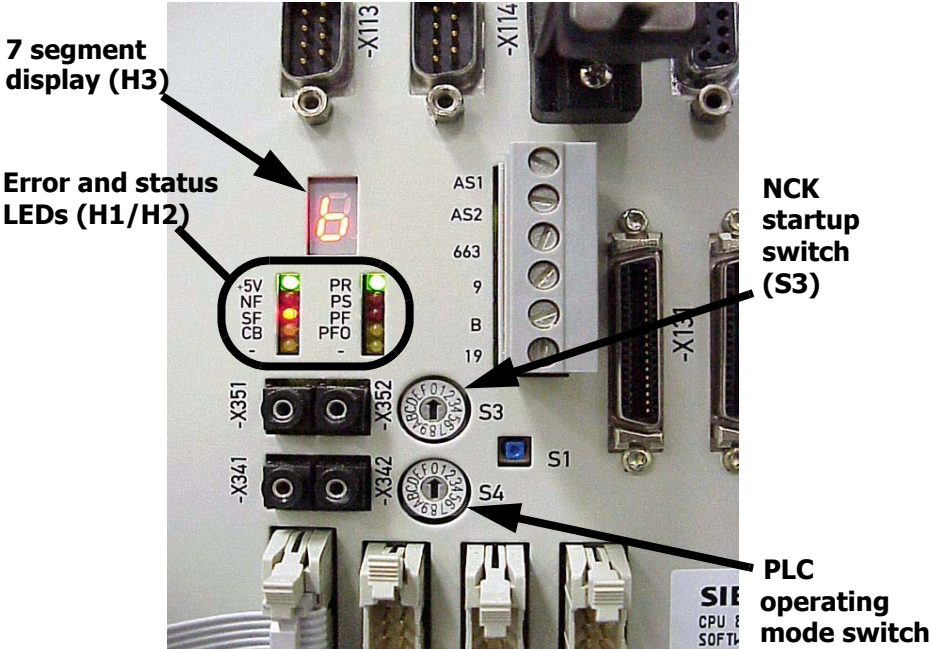

Figure 26 Switches and LED indicators used in resetting the NCK.

When the NCK is reset, all machine data is cleared and a standard machine data set is loaded into memory. The “+5V,” “SF,” and “PR” LEDs are illuminated. The 7-segment display shows a “6” (See Figure 18).

NOTE: Read the following steps thoroughly before performing the procedure. This will reduce the frequency in having to repeat these steps when not done correctly.



The following procedure resets the PLC. The overall switching sequence for switch S4 is 2 - 3 - 2 - 3 - 0, as follows:





- a. Set switch S4 to position 2 (PLC-stop). LED labeled PS lights up.
- b. Set switch S4 to position 3 (MRES). LED labeled PS turns off.
- c. Wait for LED labeled PS to light up again.
- d. Set switch S4 to position 2 and then back to position 3 within three seconds. LED labeled PS will illuminate.
- e. Wait for LED labeled PS to light up.
- f. Return S4 to position 0 (PLC-run). The green LED labeled PR will start flashing and then solid.

The machine is now running the new NC operating system and the old NC/PLC data has been erased. The PLC reset is successful if the pendant displays “Stop! No NC ready” in the message box at the upper left area of the screen.

7. Restore NCK

This step loads the *original.arc* files from the NC card into the NCK. These files are standard for all machines. Original.arc contains updated cycle files, GUDs, PLC files, and machine data.



- a. Power the machine off and back on. The error message “14011: Channel 1 block program does not exist or is not released” will display. Ignore this message.
- b. Press  Menu Select hard key.
- c. Press CNC ISO soft key, then press CNC ISO ✓ soft key.
- d. Wait for the ISO screen to load.
- e. Press  Menu Select hard key.
- f. Press Start-up soft key.
- g. Wait for the Start-up screen to load.
- h. Press Password... soft key.
- i. Press Set Password soft key.



- j. Enter the password **SUNRISE** in all UPPERCASE lettering. To type in uppercase, press and hold the **SHIFT** hard key while typing the password.
- k. Press  **INPUT** hard key. The message “*Password has been set for manufacturer*” will display in the lower part of the screen.
- l. Press  **Menu Select** hard key.
- m. Press **Services** soft key.
- n. Press  (extended menu) hard key.
- o. Press **Series start-up** soft key.
- p. Press **Original status** soft key.
- q. Press **Yes** soft key when prompted. If a “Regie” overlay error box displays during the loading process, press the  hard key. this clears the error message box.
- r. Wait for all files to load. The “Job is ready” message displays at the bottom of the display screen when files are loaded. The process will take approximately 15 minutes.
- s. Power OFF the machine and check for basic hardware configuration (see NOTE below).

NOTE: If the machine is equipped with scales and/or 4th/5th axes, the extra hardware **MUST** be disconnected so that the hardware configuration is the same as Figures 1 or 2 in the wiring diagram WRG-0002.

8. Back Up New Machine Data

The step creates a backup of the *updated* machine data to the Archive folder of the MMC103 hard drive.

- a. Press  **Menu Select** hard key.
- b. Press **Services** soft key.
- c. Select the *Archive* folder. The arrow hard keys may be used to navigate to the Archive folder.
- d. Press **Data Out** soft key.
- e. Press  (extended menu) hard key.
- f. Press **Series startup** soft key.







- g. Under *Archive contents*, remove the *X* from the *MMC* box and put an *X* in the *With compensation data* box. Use the  SELECT hard key to enter and remove the *X*.
- h. In the *Archive name* field, enter a descriptive filename for the backup file, for example, “newncplc.”
- i. Press  INPUT hard key.
- j. Select **Archive** soft key.
- k. If a message in the *Query* box displays a question about overwriting, select **YES** to overwrite.

The process will take approximately 15 minutes. The “job is ready” message will display at the bottom of the screen when the backup is complete.

9. Restore the Machine to Its Operational State





This step returns the machine to its operational state with the original zero offsets, backlash, and compensation values.

Reference each axis

- IF REQUIRED, manually jog each axis to its alignment mark
 - 1) Press  MPG hard key. Wait for LED above the key to illuminate.
 - 2) Select an axis with the axis selector switch.
 - 3) Align the selected axis to its mark by using the handwheel.
 - 4) Repeat steps 2 and 3 for all the axes.
 - 5) Press  JOG hard key when done.
- Reference the axes
 - 1) Press  Machine hard key.
 - 2) Select an axis with the axis selector switch.
 - 3) Press  REF POINT hard key.
 - 4) Press  (plus) hard key.
 - 5) Repeat steps 2, 3, and 4 for all the axes.
- The axes are referenced when the crosshair symbol  displays to the left of each axis.

Run the Options Program

- a. Press  Menu Select hard key.

- b. Press **Program** soft key.
- c. Highlight the *Workpieces* folder. Using the arrow keys, move the blue bar until the *Workpieces* folder is highlighted.
- d. Press  **INPUT** hard key.
- e. Highlight the *Shopmill* folder. Using the arrow keys, move the blue bar to highlight the *Shopmill* folder.
- f. Press  **INPUT** hard key. The contents of the Shopmill folder displays.
- g. Highlight the *Options* file and press  **INPUT** hard key. The *Editor* window opens displaying the Options program.
- h. Press the  **Pagedown** and/or **arrow** hard keys get to the Options table. The Options table lists all the available options for the Siemens control. All the listed options are set equal to zero (0). To enable an option, it must be set equal to one (1).
- i. Determine the installed options for the machine and enable it. Use the diagrams from Appendix A of this manual to identify the installed options.

To identify the installed options, compare the Siemens 810D control in the electronics cabinet, located at the back of the machine, to the options diagrams from Appendix A.

Example: A Siemens machine with an A-axis, X, Y, and Z scales installed will have a setup in the electronics cabinet resembling diagram number "5" (See Figure 19).

Therefore, the settings in the options table will be as follows:

```
_xscale=1
_yscale=1
_zscale=1
_yscale=0
_bscale=0
_a_ax=1
_b_ax=0
_V300=0
_extcolumn=0
_CogBelt=0
```

```

_ServoTurr=0
_DualArmATC=0
_HiCapATC=0
_VHT_Spindle=0
_a1200ipm=0
_m7_is_m8=0
    
```

NOTE: Setting the value to “1” enables the option. For Example, a V300 would require:

```

_a_ax=1
_a_scale=1
_V300=1
    
```

OPT-0197 & OPT-0199

5 A AXIS & X, Y, Z SCALE FOR SIEMENS

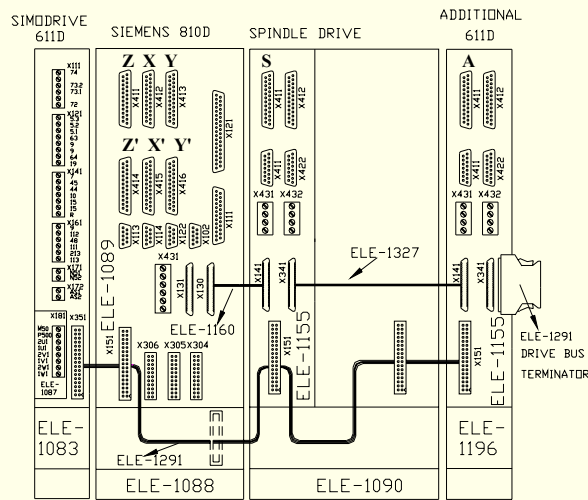



Figure 27 The X', Y', and Z' ports are used for the signal return connection from the scales. A 611D axis extension module is added for machines with 4th and 5th axes.

- j. Go back to the beginning of the program. Use arrow keys to scroll back to the top of the options program. The very first line of text should be highlighted when at the beginning of the program. This is important if the program is to be run in its entirety.
- k. Press the **Overwrite** soft key and then press the **Close editor** soft key.
- l. Press the **Select** soft key.

- m. Press the  Auto hard key.
- n. Press the  CYCLE START hard key.
- o. The *Power off* message displays at the bottom of the screen display when the program finishes running.
- p. Power the machine OFF and then back ON.
- q. Reference the axes.

Set up Tool Magazine

- a. Press the MACHINE hard key.
- b. Press the MDA hard key. Press the MDA hard key again.
- c. Type: **TC_BASE**
M2
- d. Press the CYCLE START hard key.
- e. Wait for the “WAIT” message to disappear.

Restore Gain Settings

- a. Press Menu Select hard key.
- b. Select Start-up soft key.
- c. Wait for Startup screen to load.
- d. Press **Machine data**
- e. Press **Axis specific**
- f. Go to the following machine data and type in the data from step
using the + soft key located on the upper right portion of the screen,
choose **X1** using the blue arrows go to 34090 REFP_MOVE_DIST [0]
type in data, then go to 34090 REFP_MOVE_DIST [1] and type in data
using the + soft key located on the upper right portion of the screen,
choose **Y1** using the blue arrows go to 34090 REFP_MOVE_DIST [0]
type in data, then go to 34090 REFP_MOVE_DIST [1] and type in data

using the + soft key located on the upper right portion of the screen,
choose **Z1** using the blue arrows go to 34090 REFP_MOVE_DIST [0]
type in data, then go to 34090 REFP_MOVE_DIST [1] and type in data
using the + soft key located on the upper right portion of the screen,
choose **A1** using the blue arrows go to 34090 REFP_MOVE_DIST [0]
type in data, then go to 34090 REFP_MOVE_DIST [1] and type in data

using the + soft key located on the upper right portion of the screen, choose **B1** using the blue arrows go to 34090 REFP_MOVE_DIST [0] type in data, then go to 34090 REFP_MOVE_DIST [1] and type in data

Repeat the process for the Backlash amount:

For X1, 32450 BACKLASH[0] type in data

For X1, 32450 BACKLASH[1] type in data

For Y1, 32450 BACKLASH[0] type in data

For Y1, 32450 BACKLASH[1] type in data

For Z1, 32450 BACKLASH[0] type in data

For Z1, 32450 BACKLASH[1] type in data

For A1, 32450 BACKLASH[0] type in data

For A1, 32450 BACKLASH[1] type in data

For B1, 32450 BACKLASH[0] type in data

For B1, 32450 BACKLASH[1] type in data

Repeat the process record the Gain and Band width amount:

Press the DRIVE MD soft key.

X1 1210 _____

X1 1211 _____

X1 1212 _____

X1 1407 [0] _____

Y1 1210 _____

Y1 1211 _____

Y1 1212 _____

Y1 1407 [0] _____

Z1 1210 _____

Z1 1211 _____

Z1 1212 _____

Z1 1407 [0] _____

A1 1210 _____

A1 1211 _____

A1 1212 _____

A1 1407 [0] _____

B1 1210 _____

B1 1211 _____



B1 1212 _____



B1 1407 [0] _____

- Reference the axes.
 - a. Press the Machine hard key.
 - b. Select an axis with the axis selector switch.
 - c. Press REF POINT hard key.
 - d. Press (plus) hard key.
 - e. Repeat steps 2, 3, and 4 for all the axes.

- The axes are referenced when the crosshair symbol displays to the left of each axis. Position will be restored to factory setting.

Restore Original Zero Offset and Backlash Data

- a. Press  Menu Select hard key.
- b. Press **Services** soft key.
- c. Highlight the *Workpieces* folder. Using the arrow keys, move the blue bar until the *Workpieces* folder is highlighted.
- d. Press  INPUT hard key.
- e. Highlight the *Shopmill* folder. Using the arrow keys, move the blue bar to highlight the *Shopmill* folder.
- f. Press **Data in** soft key.
- g. Press **Disk...** soft key. Insert the Utilities diskette when prompted to do so.
- h. Press **OK** soft key. An overlay box appears displaying the contents of the Utilities diskette.
- i. Highlight the *setval_s.mpf* file. Select the file by highlighting it with the blue bar.
- j. Press **Start** soft key. When the *setval_s.mpf* file is copied into the *Shopmill* folder, the overlay box closes and the message “Job is ready” displays at the bottom of the screen.

- k. Highlight the *Shopmill* folder and press the  INPUT hard key. The contents of the folder will display. Find the file named *SET_VALUE*. This is the *setval_s.mpf* program.
- l. Highlight the *SET_VALUES* file and press the  INPUT hard key. This will open the *SET_VALUES* program in an editor window.
- CAUTION:** When working in this editor window, be careful not to alter any data other than the data in the table. Altering any other data may prevent the program from running properly.
- m. Pagedown to the table (See Figure 20).

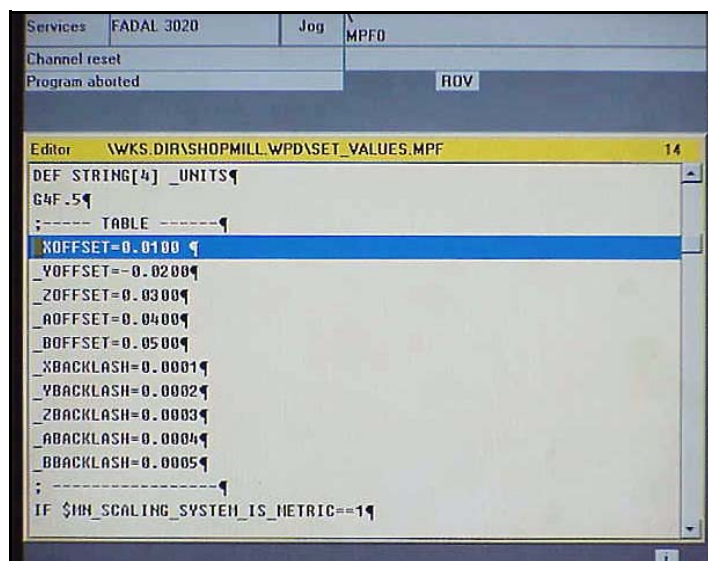



Figure 28 Enter the zero offset and backlash data in the table found in the *SET_VALUES* program.

- n. Revise the table data for the axis offsets and backlash.
- o. After entering all data, select **Overwrite** soft key.
- p. Press **Close editor** soft key when done.
- q. Press **Manage data** soft key.
- r. Press **Load** soft key. An “X” appears in the *Loaded* column (See Figure 21).
- s. Press  Menu Select hard key.
- t. Press **Program** soft key.
- u. Highlight, with blue bar, the *Shopmill* folder and press  INPUT hard key. This displays the contents of the *Shopmill* folder.

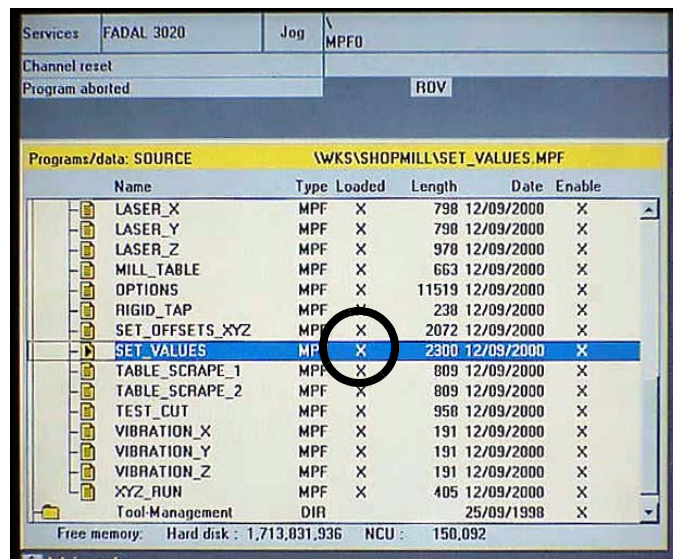







Figure 29 The SET_VALUES program must be *loaded* in order for it to run.

- v. Highlight the SET_VALUES file and press Select soft key.
- w. Press  AUTO hard key (located on the MCP).
- x. Press  CYCLE START (green) hard key. Repeat pressing the CYCLE START hard key for each of the axes until all the data values have been entered. The zero offset and backlash values display in green text at the top part of the display screen.
- y. When done, select Manage programs vertical soft key.
- z. Press Delete... soft key. This deletes the SET_VALUES program from the system. Since this is a utilities program only for entering the offset and backlash data, it is no longer needed after the data has been loaded.
- aa. Press Yes to delete the "marked file."

Run compensation values from survey sheet

The survey sheet, containing the compensation data for the machine, is stored in the electronics cabinet that is mounted at the back of the machine.

- a. Press  Menu Select hard key.
- b. Press Program soft key.
- c. Highlight the Shopmill folder. Using the arrow keys, move the blue bar to highlight the Shopmill folder.

- d. Press  INPUT hard key. The contents of the Shopmill folder displays.
 - e. Highlight the `COMP_VALUES_n` (where n is the axis) file and press the  INPUT hard key. This will open the `COMP_VALUES` program in an editor window.
- CAUTION:** When working in this editor window, be careful not to alter any data other than the data in the table. Altering any other data may prevent the program from running properly.
- f. Page down to the survey table (See Figure 22).

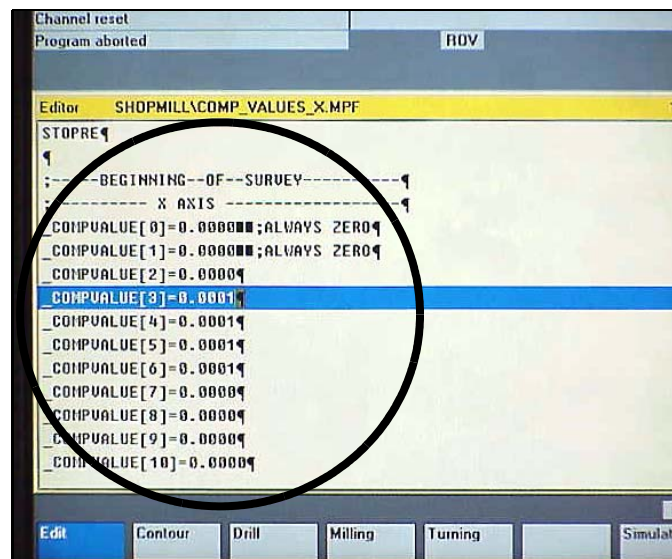



Figure 30 Go to the survey table for comp_values in the comp_value program. Enter the data, from the survey sheet, into the specified lines.

- g. Enter the compensation values into the table. *There is no need to enter the compensation values if they already exist and are correct.*
- h. After entering all the values, press the **Overwrite** soft key.
- i. Press **Close editor** soft key when done.
- j. Press **Select** soft key.
- k. Press  **AUTO** hard key.
- l. Press  **CYCLE START** hard key. This loads the values into the memory. When the program is running, the status of the program is displayed at the very top of the display screen.

m. Repeat steps e through k for all the configured axes.

n. Press  Machine hard key.

o. Press  MDA hard key.

p. Type M83 and press  INPUT hard key.

q. Type M2 and press  INPUT hard key

r. Press  CYCLE START hard key.

Wait for the control to display the alarm "510300 POWER ON needed to set spindle setup."

Power the machine off and back on.

NOTE: M83 displays the value in degrees of the measurement just performed. M83 should be run as many times as necessary until the value displayed is the same twice +/- one degree.

s. Reference the axes. (The MMC103 is in SHOPMILL after power on.)

- IF REQUIRED, manually jog each axis to its alignment mark.

1) Press  MPG hard key. Wait for LED above the key to illuminate.

2) Select an axis with the axis selector switch.

3) Align the selected axis to its mark by using the handwheel.

4) Repeat steps 2 and 3 for all the axes.

5) Press  JOG hard key when done.

- Reference the axes.

1) Press  Machine hard key.













2) Select an axis with the axis selector switch.

3) Press  REF POINT hard key.

4) Press  (plus) hard key.

5) Repeat steps 2, 3, and 4 for all the axes.

- The axes are referenced when the crosshair symbol  displays to the left of each axis.

- t. Press  Menu Select hard key.
- u. Press CNC ISO soft key, then press CNC ISO ✓ soft key.
- v. Wait for the ISO screen to load.
- w. Press  MDA hard key.
- x. Press the Delete vertical soft key.
- y. Type M83 and press  INPUT hard key.
- z. Press  CYCLE START hard key. Wait for the control to display the alarm "510300 POWER ON needed to set spindle setup."
- aa. Power the machine OFF and back ON.
- ab. Reference each axis. (The MMC103 is in SHOPMILL after power on.)
 - 1) Press  Machine hard key.
 - 2) Select an axis with the axis selector switch.
 - 3) Press  REF POINT hard key.
 - 4) Press  (plus) hard key.
 - 5) Repeat steps 2, 3, and 4 for all the axes.
- The axes are referenced when the crosshair symbol  displays to the left of each axis.
 - ac. Press  Menu Select hard key.
 - ad. Press CNC ISO soft key.
 - ae. Press CNC ISO ✓ soft key. Wait for the ISO screen to load.
 - af. Press  MDA hard key.
 - ag. Press Delete vertical soft key.
 - ah. Type M84
 - ai. Press  MDA hard key.
 - aj. Press the Delete vertical soft key.
 - ak. Type TC_BASE
 - al. Press  CYCLE START hard key.

- am. Press  Menu Select hard key.
- an. Press **Services** soft key.
- ao. Press **Data in** soft key.
- ap. Press **Archive...** vertical soft key. The *SOURCE* window opens on the lower portion of the display.
- aq. Choose the file **TO_TOA** in the *SOURCE* window by highlighting it with the blue bar.
- ar. Press **Start** vertical soft key.
- as. When message appears in the *Query* box asking to overwrite, select the **Yes all** vertical soft key. Wait for the “job is ready” message to display at the bottom of the screen.
- at. Press **Data in** soft key.
- au. Press **Archive...** vertical soft key. The *SOURCE* window opens on the lower portion of the display.
- av. Choose the file **UFR** in the *SOURCE* window by highlighting it with the blue bar.
- aw. Press **Start** vertical soft key.
- ax. When message appears in the *Query* box asking to overwrite, select the **Yes all** vertical soft key. Wait for the “job is ready” message to display at the bottom of the screen.

Reload tool data

- a. Align pocket one (1) to spindle.
- b. Perform M11 function.
- c. Load tool data.
- d. Load tool data.
- f. Load tools. (optional)

10. Back Up Hard Disk Files

If the hard disk contains files other than the ones needed for basic machine operation, such as program files and application files, they should be backed up to an external source, such as a floppy diskette, an external computer, or a network server.

Backing up files to an external computer requires a parallel computer cable. One end of the cable is connected to the LPT port of the MMC103. The other end of the cable is connected to the parallel LPT1 port of the portable computer. The BIOS setting for the LPT1 port on the external computer must be set to bi-directional.

11. Remove Old Hard Disk Unit

CAUTION:
ELECTROSTATIC SENSITIVE COMPONENTS are housed inside the MMC103 module. Use grounding straps or discharge oneself before working inside module.

The MMC103 module is located inside of the pendant cabinet. Release the two latches on the right side of the pendant cabinet to gain access to the MMC103 module (See Figure 23).

- a. POWER THE MACHINE OFF.
- b. Engage the transport safety detent. Grasp the black knob (See Figure 24). Turn it 180 degrees clockwise until the mark on the knob aligns with the mark--labeled *non-operating*--on the yellow placard. The transport safety detent is properly engaged when the knob snaps to a stop.

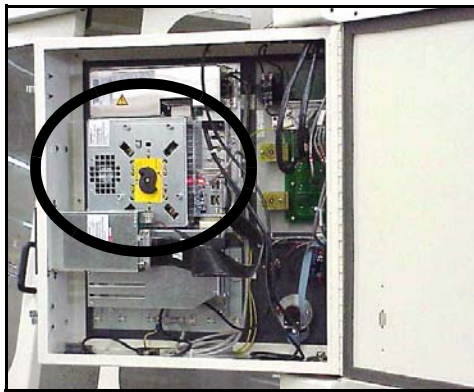

Figure 31 The MMC103 module is mounted inside the pendant cabinet.

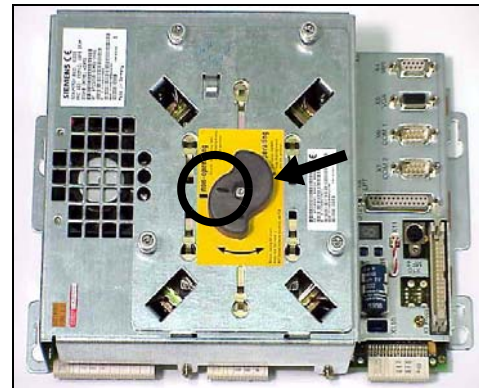

Figure 32 The transport safety detent shown in the engaged position. The mark on the knob should align with the mark on the yellow placard.

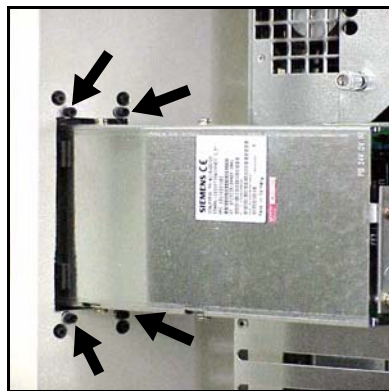

Figure 33 Four bolts mounting the floppy disk drive.

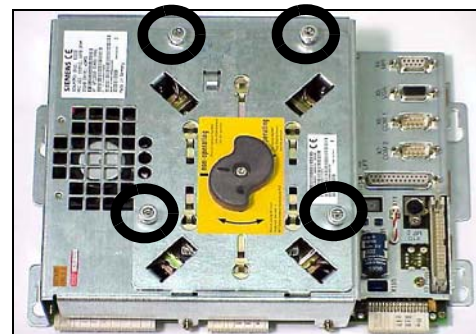

Figure 33 Unscrew the four knurled bolts to release the hard disk unit from the MMC103 module.

- c. Remove the floppy disk drive by removing the four mounting bolts (See Figure 25). Lay the drive down on the cabinet base. Make sure it is placed where it will not obstruct the hard disk removal process or is at risk of falling out from the cabinet.
- d. Release the four (4) knurled bolts that are attached to the hard disk unit (See Figure 26).
- e. CAREFULLY, swing the hard disk unit open until it rests flat from the hinge tabs.

CAUTION! Hard disk unit hook hinges are not attached to the MMC103 module.

- f. Disconnect the ribbon cable connector. Push the hook-like tabs up until the connector releases (See Figure 27). Remove the hard disk.

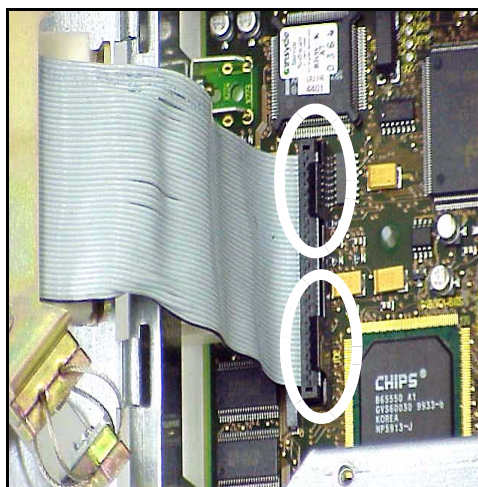

Figure 34 Ribbon cable is locked in place by the hook-like tabs on the cable plug.

12. Install New Pre-imaged Hard Disk

CAUTION:

ELECTROSTATIC SENSITIVE COMPONENTS are housed inside the MMC103 module. Use grounding straps or discharge oneself before working inside module.

WARNING:

The following procedure replaces the machine's hard disk ALL OF THE EXISTING DATA ON THE HARD DRIVE WILL BE ERASED! Get customer approval before performing this procedure. SAVE ALL NC programs and machine data to a disk or another storage location.

Installation of the new pre-imaged hard disk unit is, basically, the reverse of removal.

- a. Insert the hinge tabs of the hard disk unit into the two hinge slots of the MMC103 module. Let the hard disk unit rest on the hinge tabs.
- b. CAREFULLY, insert the ribbon cable connector into the connector plug. BE CAREFUL NOT TO BEND ANY OF THE CONNECTOR PINS ON THE PLUG. Make sure the hook-like tabs snap over the connector to lock it in place. The ribbon cable must be flat, without any twists in it.
- c. Swing the hard disk unit up to close it.
- d. Tighten the four (4) knurled bolts with fingers.
- e. Remount the floppy disk drive.
- f. Disengage the transport safety detent. Grasp the black knob (See Figure 28). Turn it 180 degrees counter-clockwise until the mark on the knob aligns with the mark--labeled *operating*--on the yellow placard. The transport safety detent is properly engaged when the knob snaps to a stop.
- g. POWER THE MACHINE ON.

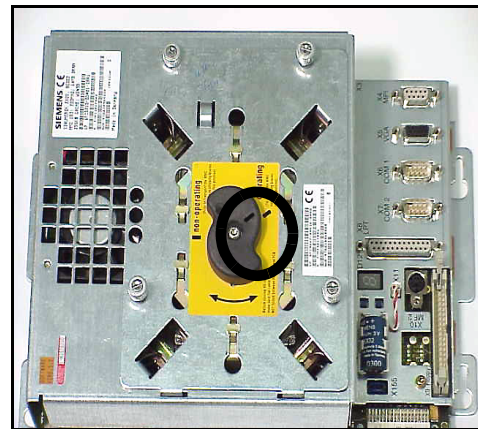

Figure 35 The transport safety detent shown in the disengaged position. The mark on the knob should align with the mark on the yellow placard.

13. Display (HMI) Firmware

The MMC103 has the software pre installed.



- a) Power ON.
- b) Press ENTER to bypass password. Wait this may take 5 minutes to boot up.
- c) Press MENU SELECT.
- d) Press ISO soft key.
- e) Press CNC ISO soft key.
- f) Wait as machine changes over to service side (ISO).
- g) Press MENU SELECT.
- h) Press START UP.
- i) Press PASSWORD.
- j) Press SET PASSWORD.



- k) Hold the SHIFT button and type SUNRISE.
- l) Press OK.
- m) Press MMC.
- n) Press OPERATOR PANEL.
- o) Change the data to read as follows:
 - 810D
 - Connection 1:1
 - BusMPI
 - Highest Bus address31
 - MMC address1
 - NCK address3
 - PLC address2
- p) Press MENU SELECT hard key
- q) Use the extension key >
- r) Press EXIT, Wait as system shuts down
- s) Press any key to reboot system

Note: Wait as system reboots, this may be as long as 5 to 10 minutes.

14. Back Up New Machine Data

The following procedure creates a backup of the updated machine data to the Archive folder on the MMC103 hard disk.

- a. Press  Menu Select hard key.
- b. Press CNC ISO soft key, then press CNC ISO ✓ soft key.
- c. Wait for the ISO screen to display.
- d. Press  Menu Select hard key.
- e. Press Services soft key.
- f. Choose the *Archive* folder. The arrow hard keys may be used to navigate to the Archive folder.
- g. Press Data Out soft key.
- h. Press  (extended menu) hard key.
- i. Press Series start-up soft key.



- j. Under *Archive contents*, remove the *X* from the *MMC* box and put an *X* in the *With compensation data* box. Use the SELECT  hard key to enter and remove the *X*.
- k. In the *Archive name* field, enter a descriptive filename for the backup file, for example, "backupnew."
- l. Press  **Input** hard key.
- m. Press **Archive** soft key.
- n. If a message in the *Query* box displays a question about overwriting, select **YES**.

The process will take approximately fifteen minutes. The "job is ready" message will display at the bottom of the screen when the backup is complete.

15. Create Backup to a Diskette

Create a backup copy of the updated machine data on a 3.5 inch diskette. This backup copy will be sent Fadal Machining Centers.

NOTE: This step should be performed following step 13. If this step is not performed following step 13, some of the soft keys indicated in the procedure may not display.

- a. Press  **Menu Select** hard key.
- b. Press **Data out** soft key.
- c. Choose the *Archive* folder. Press  **Input** hard key.
- d. Choose the updated backup file, such as "backupnew."
- e. Press **Disk...** soft key.
- f. Insert blank 3.5 inch floppy diskette into the drive.
- g. Press **OK** soft key.
- Verify the "Disk:TARGET" window shows an **A:** in the yellow bar.
- Verify the *Archive* field displays the name of the new backup file.
- Verify the *ARCH* field displays "Binary format(PC form.)."
- h. Press **Start** soft key. **WAIT** while the files get copied to the diskette.
- i. When "Job is ready," remove diskette from drive.
- j. On a diskette label, write the serial number of the machine from which this backup data is from. Apply the label to the diskette.
- k. Send this diskette to Fadal Machining Centers.

DATC Hardware Update v1.7.2 (or above)

IMPORTANT! MMC103 DATC Software Update **MUST BE INSTALLED FIRST**. Check to see if the VMC has a PCB-0230 (1330-0A) board. If not, complete this procedure. If the VMC is equipped with Servo-Turret ATC or Geneva ATC, either 21 or 30 tools, then **do not** perform this procedure. It is only intended for the Dual Arm Automatic Tool Changer.

General Information

Check the existing Siemens hardware before proceeding with this update. Compare the hardware to WRG-0002 REV F (see Appendix A). If the ports and cables are found to be a different configuration, then order the replacement part(s) and install prior to proceeding with this update.

Tools Required

The components required are as follows:

PCB-0230 PCB, DATC CONTROLLER; SIEMENS 1330 (includes PLC Chip for 1330 card; **must be Siemens Version 2.02**)

Cable, 2010-1/J3 to 1100-1/J3

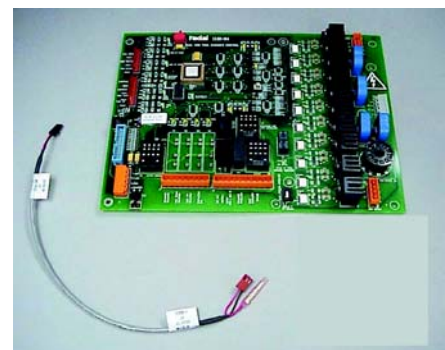

Figure 36 PCB-0230 and 2010-1/J3 to 1100-1/J3 Cable

For information on Cable setup, see the wiring diagram at the end of this manual.

1. Replace Hardware for DATC

- a. Turn the main power off.
- b. Replace existing 1330-0A DATC Controller with new PCB-0230 1330-0A. Make sure that the PLC Chip is Siemens Version 2.02.
- c. If necessary, attach Cable 2010-1/J3 to 1100-1/J3. If the cable is missing, and if a single wire currently exists at 1100-1/J3 connecting to 1980-0 or 2000-0 or 2030-0 board, then cut the connector off of the existing wire, insert it into a new cable at the butt splice on the red wire and crimp. Then install the new cable.
- d. Repackage the removed components and return them to Fadal with a PCR form for each part for credit.

<i>Axis Travel</i>	<i>5th Axis Restricted?</i>	<i>System</i>	<i>Control</i>	<i>Language</i>	<i>Part Number</i>	<i>Description</i>
3020	NO (Standard)	810D	MMC100	English / German	ELE-1392	SFTUPD SIEMNS;3020/810/100/GRM
				English / Italian	ELE-1393	SFTUPD SIEMNS;3020/810/100/ITL
				English / Spanish	ELE-1394	SFTUPD SIEMNS;3020/810/100/SPN
				English / French	ELE-1395	SFTUPD SIEMNS;3020/810/100/FRN
3020	NO (Standard)	810D	MMC103	English / German	ELE-1396	SFTUPD SIEMNS;3020/810/103/GRM
				English / Italian	ELE-1397	SFTUPD SIEMNS;3020/810/103/ITL
				English / Spanish	ELE-1398	SFTUPD SIEMNS;3020/810/103/SPN
				English / French	ELE-1399	SFTUPD SIEMNS;3020/810/103/FRN
3020	NO (Standard)	840D	MMC103	English / German	ELE-1408	SFTUPD SIEMNS;3020/840/103/GRM
				English / Italian	ELE-1409	SFTUPD SIEMNS;3020/840/103/ITL
				English / Spanish	ELE-1410	SFTUPD SIEMNS;3020/840/103/SPN
				English / French	ELE-1411	SFTUPD SIEMNS;3020/840/103/FRN
4525	NO (Standard)	810D	MMC100	English / German	ELE-1416	SFTUPD SIEMNS;4525/810/100/GRM
				English / Italian	ELE-1417	SFTUPD SIEMNS;4525/810/100/ITL
				English / Spanish	ELE-1418	SFTUPD SIEMNS;4525/810/100/SPN
				English / French	ELE-1419	SFTUPD SIEMNS;4525/810/100/FRN
4525	NO (Standard)	810D	MMC103	English / German	ELE-1420	SFTUPD SIEMNS;4525/810/103/GRM
				English / Italian	ELE-1421	SFTUPD SIEMNS;4525/810/103/ITL
				English / Spanish	ELE-1422	SFTUPD SIEMNS;4525/810/103/SPN
				English / French	ELE-1423	SFTUPD SIEMNS;4525/810/103/FRN
4525	NO (Standard)	840D	MMC103	English / German	ELE-1432	SFTUPD SIEMNS;4525/840/103/GRM
				English / Italian	ELE-1433	SFTUPD SIEMNS;4525/840/103/ITL
				English / Spanish	ELE-1434	SFTUPD SIEMNS;4525/840/103/SPN
				English / French	ELE-1435	SFTUPD SIEMNS;4525/840/103/FRN
4525	YES (Export) 5th Axis Restricted	840D	MMC103	English / German	ELE-1436	SFTUPD 5THRES;4525/840/103/GRM
				English / Italian	ELE-1437	SFTUPD 5THRES;4525/840/103/ITL
				English / Spanish	ELE-1438	SFTUPD 5THRES;4525/840/103/SPN
				English / French	ELE-1439	SFTUPD 5THRES;4525/840/103/FRN
3020	YES (Export) 5th Axis Restricted	810D	MMC100	English / German	ELE-1400	SFTUPD 5THRES;3020/810/100/GRM
				English / Italian	ELE-1401	SFTUPD 5THRES;3020/810/100/ITL
				English / Spanish	ELE-1402	SFTUPD 5THRES;3020/810/100/SPN
				English / French	ELE-1403	SFTUPD 5THRES;3020/810/100/FRN
3020	YES (Export) 5th Axis Restricted	810D	MMC103	English / German	ELE-1404	SFTUPD 5THRES;3020/810/103/GRM
				English / Italian	ELE-1405	SFTUPD 5THRES;3020/810/103/ITL
				English / Spanish	ELE-1406	SFTUPD 5THRES;3020/810/103/SPN
				English / French	ELE-1407	SFTUPD 5THRES;3020/810/103/FRN
3020	YES (Export) 5th Axis Restricted	840D	MMC103	English / German	ELE-1412	SFTUPD 5THRES;3020/840/103/GRM
				English / Italian	ELE-1413	SFTUPD 5THRES;3020/840/103/ITL
				English / Spanish	ELE-1414	SFTUPD 5THRES;3020/840/103/SPN
				English / French	ELE-1415	SFTUPD 5THRES;3020/840/103/FRN
4525	YES (Export) 5th Axis Restricted	810D	MMC100	English / German	ELE-1424	SFTUPD 5THRES;4525/810/100/GRM
				English / Italian	ELE-1425	SFTUPD 5THRES;4525/810/100/ITL
				English / Spanish	ELE-1426	SFTUPD 5THRES;4525/810/100/SPN
				English / French	ELE-1427	SFTUPD 5THRES;4525/810/100/FRN
4525	YES (Export) 5th Axis Restricted	810D	MMC103	English / German	ELE-1428	SFTUPD 5THRES;4525/810/103/GRM
				English / Italian	ELE-1429	SFTUPD 5THRES;4525/810/103/ITL
				English / Spanish	ELE-1430	SFTUPD 5THRES;4525/810/103/SPN
				English / French	ELE-1431	SFTUPD 5THRES;4525/810/103/FRN

Section 07: Parameters

Setting Options on the Fadal Siemens

Of the many parameters of the Siemens machine, there are some that are set aside to configure the Fadal Machine. These parameters turn ON or OFF options that are presently installed on the machine. If the option is turned on but not installed then the Siemens control will give Alarms and Warnings that something is invalid. To avoid these Alarms and Warnings, make sure the option is installed properly before turning ON any options.

The USER_DATA_HEX values are entered in as Hexadecimal values. This is indicated by it's name that ends in HEX. The options themselves are binary coded, which we will describe in another table below. Hexadecimal describes a base-16 number system. That is, it describes a numbering system containing 16 sequential numbers as base units (including 0) before adding a new position for the next number. (Note that we're using "16" here as a decimal number to explain a number that would be "10" in hexadecimal.) The hexadecimal numbers are 0-9 and then use the letters A-F. We show the equivalence of binary, decimal, and hexadecimal numbers in the table below.

Binary	Decimal	Hexadecimal
00000000	0	0
00000001	1	1
00000010	2	2
00000011	3	3
00000100	4	4
00000101	5	5
00000110	6	6
00000111	7	7
00001000	8	8
00001001	9	9
00001010	10	A
00001011	11	B
00001100	12	C
00001101	13	D
00001110	14	E
00001111	15	F
00010000	16	10
Etc.	Etc.	Etc.

Notice how in the binary column of the table above the numbers alternate from 1 to 0, or turn ON and OFF. This is how we will use the table below to turn options ON or OFF.

	bit 7	bit 6	Bit 5	bit 4	bit 3	bit 2	bit 1	bit 0
14512 USER_DATA_HEX[0]	B axis	A axis	B scale	A scale	Z scale	Y scale	X scale	Rigid Tapping
14512 USER_DATA_HEX[1]	Simulator	M7/M8 toggle	V300 Rotary table	Extended Column	HMC Pallet Changer	DATC	Servo Turret	15K Spindle

For the first USER_DATA_HEX[0], there are 8 options available. Using the two tables above the hexadecimal values can be determined. For example, to turn on the rigid tapping option, the bit 0 will be set which would equate to 1 hex. To turn ON A scales and Rigid Tapping, bit 4 and bit 0 will be set which would equate to 11 hex. To turn on all options in USER_DATA_HEX[0], all the bits would be set which would equate to FF hex.

Setting the Bits

Rigid Tapping
X scale
Y scale
Z scale
A scale
B scale
A axis
B axis
15K spindle
Servo Turret

Setting this bit will [by-pass the 200ms timer set for the regular geneva time lag](#). The geneva needs lag so that the geneva motor will coast and lock the turret. But the servo turret needs to instantly turn off.

DATC
HMC Pallet Changer
Extended Column
V300 Rotary table
M7/M8 Toggle
Simulator

How To set the number of tools in the ATC magazine

The number of tools in the tool change magazine is stored in another Siemens user data location, 14510 USER_DATA_INT[0]. This data is entered in decimal integer numbers, as indicated by the INT in the data name.

To set to 24 tool DATC:

14510 USER_DATA_INT[0] = **24**

To set to 32 tool DATC:

14510 USER_DATA_INT[0] = 32

OPTIONS BYTE BY BYTE AND BIT BY BIT

V2.0

Location in db20 MD number	Bit 7	Bit 6	Bit 5	Bit 4	Bit 3	Bit 2	Bit 1	Bit 0
Bytes 0 and 1 MD14510[0]	Tool Magazine Capacity (Integer)							
Byte 2 MD14512[0]	b axis	a axis	b scale	a scale	z scale	yscale	x scale	Rigid Tapping
Byte 3 MD14512[1]	Simulator	m//m8 toggle	v300	Ext Column	HMC Pallet Xer	DATC	Servo Turret	15K Spindle

The Options program

This program will set bits in the MD14512 bytes and set various data bytes to configure options loaded on the machine like spindle types, scales and rotary types.

A listing of the program is shown below:

```

_N_OPTIONS_MPF
; $PATH=/_N_WKS_DIR/_N_SHOPMILL_WPD
; FADAL V1.6 07/00 FOR 4525 AND 3020 BY DM
; 810D Version
def bool
_ridtap=1, _xscale, _yscale, _zscale, _ascale, _bscale, _extcolumn, _a1200ipm
def bool
_a_ax, _b_ax, _CogBelt, _ServoTurr, _DualArmATC, _HiCapATC, _VHT_Spindle
;
; SET UP OPTIONS BELOW
; ----- 1=on 0=off -----
;
_xscale=0 ;X scale
_yscale=0 ;Y scale
_zscale=0 ;Z scale
_ascale=0 ;A scale
_bscale=0 ;B scale
_a_ax=0 ;A axis
_b_ax=0 ;B axis
_extcolumn=0 ;Extended colum 32" z axis
_CogBelt=0 ;15K cogged belt spindle
_ServoTurr=0 ;Servo turret ATC
_DualArmATC=1 ;Dual arm ATC
_HiCapATC=0 ;High Capacity Turret ATC
_VHT_Spindle=0 ;Very High Torque Spindle
_a1200ipm=0 ;1200 ipm xy axes
;-----
CHANDATA (1)

if _ridtap==1
msg ("RIGID TAPPING")
g4f2

```

```

$MN_USER_DATA_HEX[0]=$MN_USER_DATA_HEX[0] B_OR 'B00000001' ;ACT
RIDG TAP
else
msg ("NO RIGID TAPPING")
g4f2
$MN_USER_DATA_HEX[0]=$MN_USER_DATA_HEX[0] B_AND 'B11111110'
;DEACT RIDG TAP
endif
stopre

if _a_ax==0
msg ("NO A AXIS ")
g4f2
$MC_AXCONF_MACHAX_USED[4]=0;DEACT A AX IN NCK
$MN_USER_DATA_HEX[0]=$MN_USER_DATA_HEX[0] B_AND 'B10111111' ;DEACT A AX
IN PLC
$MN_DRIVE_LOGIC_NR[6]=0 ;REMOVE DR IN SLOT 7
$MN_DRIVE_IS_ACTIVE[6]=0;DEACT DR IN SLOT 7
$MN_DRIVE_LOGIC_NR[7]=0 ;REMOVE DR IN SLOT 8
$MN_DRIVE_IS_ACTIVE[7]=0 ;DEACT DR IN SLOT 8
endif
stopre

if _a_ax==1
$MN_USER_DATA_HEX[0]=$MN_USER_DATA_HEX[0] B_OR 'B01000000';ACT A AX IN
PLC
$MC_AXCONF_MACHAX_USED[4]=5;ACT A AX IN NCK
$MA_CTRLOUT_MODULE_NR[0,AX5]=7;A AXIS DRV 7
$MA_ENC_MODULE_NR[0,AX5]=7;ENCDR 1 DRV 7
$MA_ENC_MODULE_NR[1,AX5]=7;ENCDR 2 DRV 7
endif
stopre

if (_a_ax==1) and (_zscale==0)
msg ("A AXIS NO Z SCALE")
g4f2
$MN_DRIVE_LOGIC_NR[6]=7 ;ASSIGN DRIVE 7 TO SLOT 7
$MN_DRIVE_IS_ACTIVE[6]=0 ;ACTIVATE DRIVE
IN SLOT 7
$MN_DRIVE_LOGIC_NR[7]=0 ;REMOVE DR IN SLOT 8
$MN_DRIVE_IS_ACTIVE[7]=0 ;DEACT DR IN SLOT 8
$MN_DRIVE_INVERTER_CODE[6]='H14';25A PWR SEC
$MN_DRIVE_MODULE_TYPE[6]=1;1AX PWR SEC
endif
stopre

if (_a_ax==1) and (_zscale==1)
msg ("A AXIS Z SCALE")
g4f2
$MN_DRIVE_LOGIC_NR[7]=7 ;ASSIGN DRIVE 7 TO SLOT 8
$MN_DRIVE_IS_ACTIVE[7]=0 ;ACTIVATE DRIVE
IN SLOT 8
$MN_DRIVE_INVERTER_CODE[7]='H14'
$MN_DRIVE_MODULE_TYPE[7]=1;1AX PWR SEC
$MN_DRIVE_LOGIC_NR[6]=10;ASSIGN DR 10 TO SLOT 7
$MN_DRIVE_IS_ACTIVE[6]=0;DEACTIVATE DRIVE IN SLOT 7
endif

```

```

stopre

if _b_ax==0
msg ("NO B AXIS ")
g4f2
$MC_AXCONF_MACHAX_USED[5]=0;DEACT B AX IN NCK
$MN_USER_DATA_HEX[0]=$MN_USER_DATA_HEX[0] B_AND 'B01111111' ;DEACTIVATE
B AXIS IN PLC
$MN_DRIVE_LOGIC_NR[8]=0 ;REMOVE DR IN SLOT 9
$MN_DRIVE_IS_ACTIVE[8]=0 ;DEACT DR IN SLOT 9
endif
stopre

if (_b_ax==0) and (_a_ax==0)
$MN_DRIVE_LOGIC_NR[7]=0 ;REMOVE DR IN SLOT 8
$MN_DRIVE_IS_ACTIVE[7]=0;DEACT DR IN SLOT 8
endif
stopre

if _b_ax==1
$MC_AXCONF_MACHAX_USED[5]=6;ACT B AX IN NCK
$MN_USER_DATA_HEX[0]=$MN_USER_DATA_HEX[0] B_OR 'B10000000' ;ACTIVATE B
AXIS IN PLC
$MA_CTRLOUT_MODULE_NR[0,AX6]=8;B AXIS DRV 8
$MA_ENC_MODULE_NR[0,AX6]=8;ENCDR 1 DRV 8 B AX
$MA_ENC_MODULE_NR[1,AX6]=8;ENCDR 2 DRV 8 B AX
endif
stopre

if (_b_ax==1) and (_zscale==0)
msg ("B AXIS NO Z SCALE")
g4f2
$MN_DRIVE_LOGIC_NR[7]=8 ;ASSIGN DR 8 TO SLOT 8
$MN_DRIVE_IS_ACTIVE[7]=0 ;DEACT DR IN SLOT
8
$MN_DRIVE_INVERTER_CODE[7]='H14'
$MN_DRIVE_MODULE_TYPE[6]=2;2AX PWR SEC DR 7 AND 8
$MN_DRIVE_MODULE_TYPE[7]=2;2AX PWR SEC
$MN_DRIVE_LOGIC_NR[8]=0 ;REMOVE DRIVE IN SLOT 9
endif
stopre

if (_b_ax==1) and (_zscale==1)
msg ("B AXIS Z SCALE ")
g4f2
$MN_DRIVE_LOGIC_NR[8]=8 ;MOVE DRIVE 8 TO SLOT 9
$MN_DRIVE_IS_ACTIVE[8]=0 ;ACTIVATE DRIVE
IN SLOT 9
$MN_DRIVE_INVERTER_CODE[8]='H14'
$MN_DRIVE_MODULE_TYPE[7]=2;2AX PWR SEC DR 8 AND 9
$MN_DRIVE_MODULE_TYPE[8]=2;2AX PWR SEC
endif
stopre

if _xscale==1
msg ("X SCALE ")
g4f2

```

```

$MA_NUM_ENCS[AX1]=2          ;SET X FOR 2 ENCODERS
$MN_USER_DATA_HEX[0]=$MN_USER_DATA_HEX[0] B_OR 'B00000010' ;ACTIVATE X
SCALE
else
msg ("NO X SCALE ")
g4f2
$MA_NUM_ENCS[AX1]=1          ;SET X FOR 1 ENCODER
$MN_USER_DATA_HEX[0]=$MN_USER_DATA_HEX[0] B_AND 'B11111101' ;DEACTIVATE
X SCALE
endif
stopre

if _yscale==1
msg ("Y SCALE ")
g4f2
$MA_NUM_ENCS[AX2]=2          ;SET Y FOR 2 ENCODERS
$MN_USER_DATA_HEX[0]=$MN_USER_DATA_HEX[0] B_OR 'B00000100' ;ACTIVATE Y
SCALE
else
msg ("NO Y SCALE ")
g4f2
$MA_NUM_ENCS[AX2]=1          ;SET Y FOR 1 ENCODER
$MN_USER_DATA_HEX[0]=$MN_USER_DATA_HEX[0] B_AND 'B11111011' ;DEACTIVATE
Y SCALE
endif
stopre

if _zscale==1
msg ("Z SCALE ")
g4f2
$MA_NUM_ENCS[AX3]=2          ;SET Z FOR 2 ENCODERS
$MN_USER_DATA_HEX[0]=$MN_USER_DATA_HEX[0] B_OR 'B00001000' ;ACTIVATE Z
SCALE
$MA_ENC_MODULE_NR[1,AX3]=9;SET SCALE INPUT FOR SLOT 4
$MN_DRIVE_LOGIC_NR[3]=9      ;MOVE Z' FEEDBACK TO SLOT 4
$MN_DRIVE_IS_ACTIVE[3]=0;INACTIVATE DRIVE IN SLOT 4
$MN_DRIVE_LOGIC_NR[6]=4      ;MOVE SPINDLE TO SLOT 7
$MN_DRIVE_IS_ACTIVE[6]=1;ACTIVATE DRIVE IN SLOT 7
$MN_DRIVE_TYPE[6]=2          ;SP DR
$MN_DRIVE_INVERTER_CODE[6]=$MN_DRIVE_INVERTER_CODE[3];COPY PWR SEC CODE
$MN_DRIVE_MODULE_TYPE[6]=1;1AX PWR SEC
else
msg ("NO Z SCALE ")
g4f2
$MA_NUM_ENCS[AX3]=1          ;SET Z FOR 1 ENCODER
$MN_USER_DATA_HEX[0]=$MN_USER_DATA_HEX[0] B_AND 'B11110111' ;DEACTIVATE
Z SCALE IN PLC
$MA_ENC_MODULE_NR[1,AX3]=1;SET 2ND INPUT FOR SLOT 1
$MN_DRIVE_LOGIC_NR[3]=4      ;MOVE SPINDLE TO SLOT 4
$MN_DRIVE_IS_ACTIVE[3]=1;ACTIVATE DRIVE IN SLOT 4
$MN_DRIVE_TYPE[6]=1          ;FEED DR
endif
stopre

if _ascale==1
msg ("A SCALE ")
g4f2

```



```

$MA_NUM_ENCS[AX5]=2          ;SET A FOR 2 ENCODERS
$MN_USER_DATA_HEX[0]=$MN_USER_DATA_HEX[0] B_OR 'B00010000' ;ACTIVATE A
SCALE
else
msg ("NO A SCALE ")
g4f2
$MA_NUM_ENCS[AX5]=1          ;SET A FOR 1 ENCODER
$MN_USER_DATA_HEX[0]=$MN_USER_DATA_HEX[0] B_AND 'B11101111' ;DEACTIVATE
A SCALE
endif
stopre

if _bscale==1
msg ("B SCALE ")
g4f2
$MA_NUM_ENCS[AX6]=2          ;SET B FOR 2 ENCODERS
$MN_USER_DATA_HEX[0]=$MN_USER_DATA_HEX[0] B_OR 'B00100000' ;ACTIVATE B
SCALE
else
msg ("NO B SCALE ")
g4f2
$MA_NUM_ENCS[AX6]=1          ;SET B FOR 1 ENCODER
$MN_USER_DATA_HEX[0]=$MN_USER_DATA_HEX[0] B_AND 'B11011111' ;DEACTIVATE
B SCALE
endif
stopre
if _CogBelt==1
msg ("15K SPINDLE")
g4f2
$MN_USER_DATA_HEX[1]=$MN_USER_DATA_HEX[1] B_OR 'B00000001' ;ENBL 15K
SPINDLE IN PLC
$MA_MAX_AX_VELO[AX4]=15000;SET MAX AX SPD
$MA_DRIVE_AX_RATIO_NUMERA[0,AX4]=50000;1 TO 2 RATIO C AXIS MODE
$MA_DRIVE_AX_RATIO_NUMERA[1,AX4]=50000;1 TO 2 RATIO 1ST GEAR
$MA_DRIVE_AX_RATIO_NUMERA[2,AX4]=50000;1 TO 2 RATIO 2ND GEAR
$MA_GEAR_STEP_CHANGE_ENABLE[AX4]=0;DIS GEAR CHGE
$MA_SPIND_VELO_LIMIT[AX4]=15000;MAX ABSOLUTE SPEED 15K
$MA_GEAR_STEP_MAX_VELO[0,AX4]=15000;MAX SP TO 15K C AXIS MODE
$MA_GEAR_STEP_MAX_VELO[1,AX4]=15000;MAX SP TO 15K 1ST GEAR
$MA_GEAR_STEP_MAX_VELO[2,AX4]=15000;MAX SP TO 15K 2ND GEAR
$MA_GEAR_STEP_MAX_VELO_LIMIT[0,AX4]=15500;MAX SP LIM C AXIS MODE
$MA_GEAR_STEP_MAX_VELO_LIMIT[1,AX4]=15500;MAX SP LIM 1ST GEAR
$MA_GEAR_STEP_SPEEDCTRL_ACCEL[0,AX4]=175;ACCEL C AXIS
$MA_GEAR_STEP_SPEEDCTRL_ACCEL[1,AX4]=175;ACCEL 1ST GEAR
$MA_AX_VELO_LIMIT[0,AX4]=15500;SPEED LIMIT C AXIS
$MA_AX_VELO_LIMIT[1,AX4]=15500;SPEED LIMIT 1ST GEAR
else
msg ("NO 15K SPINDLE")
g4f2
$MN_USER_DATA_HEX[1]=$MN_USER_DATA_HEX[1] B_AND 'B11111110' ;DIS 15K
SPINDLE IN PLC
$MA_MAX_AX_VELO[AX4]=10000;SET MAX AX SPD
$MA_DRIVE_AX_RATIO_NUMERA[0,AX4]=194000;2 TO 1 RATIO C AXIS MODE
$MA_DRIVE_AX_RATIO_NUMERA[1,AX4]=194000;2 TO 1 RATIO 1ST GEAR
$MA_DRIVE_AX_RATIO_NUMERA[2,AX4]=51600;1 TO 2 RATIO 2ND GEAR
$MA_GEAR_STEP_CHANGE_ENABLE[AX4]=1;ENBL GEAR CHGE
$MA_SPIND_VELO_LIMIT[AX4]=10000;MAX ABS SP 10K

```

```

$MA_GEAR_STEP_MAX_VELO[0,AX4]=2500;MAX SP 2.5K C AXIS MODE
$MA_GEAR_STEP_MAX_VELO[1,AX4]=2500;MAX SP 2.5K 1ST GEAR
$MA_GEAR_STEP_MAX_VELO[2,AX4]=10000;MAX SP 10K 2ND GEAR
$MA_GEAR_STEP_MIN_VELO[2,AX4]=2501;MIN SP HIGH TO LOW
$MA_GEAR_STEP_MAX_VELO_LIMIT[0,AX4]=2500;MAX SP LIM C AXIS MODE
$MA_GEAR_STEP_MAX_VELO_LIMIT[1,AX4]=2500;MAX SP LIM 1ST GEAR
$MA_GEAR_STEP_SPEEDCTRL_ACCEL[0,AX4]=300;ACCEL C AXIS
$MA_GEAR_STEP_SPEEDCTRL_ACCEL[1,AX4]=300;ACCEL 1ST GEAR
$MA_AX_VELO_LIMIT[0,AX4]=3000;SPEED LIMIT C AXIS
$MA_AX_VELO_LIMIT[1,AX4]=3000;SPEED LIMIT 1ST GEAR
endif
stopre

if _ServoTurr==1
msg ("SERVO TURRET")
g4f2
$MN_USER_DATA_HEX[1]=$MN_USER_DATA_HEX[1] B_OR 'B00000010' ;ENBL SERVO
TURR IN PLC
else
msg ("STANDARD TURRET")
g4f2
$MN_USER_DATA_HEX[1]=$MN_USER_DATA_HEX[1] B_AND 'B11111101' ;DIS SERVO
TURR IN PLC
endif
stopre

if _HiCapATC==1
msg ("HIGH CAP ATC")
g4f2
$MN_USER_DATA_HEX[1]=$MN_USER_DATA_HEX[1] B_OR 'B00001000' ;ENBL HIGH
CAP ATC IN PLC
else
msg ("STD CAP ATC")
g4f2
$MN_USER_DATA_HEX[1]=$MN_USER_DATA_HEX[1] B_AND 'B11110111' ;DIS HIGH
CAP ATC IN PLC
endif
stopre

if _VHT_Spindle==1
msg ("VHT SPINDLE")
g4f2
$MA_CTRLOUT_MODULE_NR[0,AX4]=10;CHG SP TO DRV 10
$MA_ENC_MODULE_NR[0,AX4]=10;SP FEEDBACK 1 DRV 10
$MA_ENC_MODULE_NR[1,AX4]=10;SP FEEDBACK 2 DRV 10
else
msg ("HT SPINDLE")
g4f2
$MA_CTRLOUT_MODULE_NR[0,AX4]=4;CHG SP TO DRV 4
$MA_ENC_MODULE_NR[0,AX4]=4;SP FEEDBACK 1 DRV 4
$MA_ENC_MODULE_NR[1,AX4]=4;SP FEEDBACK 2 DRV 4
endif
stopre

if (_VHT_Spindle==1) and (_zscale==0)
$MN_DRIVE_LOGIC_NR[3]=10 ;USE VHT BOOT FILE

```

```
$MN_DRIVE_INVERTER_CODE[3]='H9' ;BIG POWER
SECTION
endif
stopre

if (_VHT_Spindle==0) and (_zscale==0)
$MN_DRIVE_LOGIC_NR[3]=4 ;USE HT BOOT FILE
$MN_DRIVE_INVERTER_CODE[3]='Hd' ;SML POWER
SECTION
endif
stopre

if (_VHT_Spindle==1) and (_zscale==1)
$MN_DRIVE_LOGIC_NR[6]=10 ;USE VHT BOOT FILE
$MN_DRIVE_INVERTER_CODE[6]='H9' ;BIG POWER
SECTION
endif
stopre

if (_VHT_Spindle==0) and (_zscale==1)
$MN_DRIVE_LOGIC_NR[6]=4 ;USE HT BOOT FILE
$MN_DRIVE_INVERTER_CODE[6]='Hd' ;SML POWER
SECTION
endif
stopre

if _DualArmATC==1
msg ("DUAL ARM ATC")
g4f2
$MN_USER_DATA_HEX[1]=$MN_USER_DATA_HEX[1] B_OR 'B00000100' ;ENBL DATC
IN PLC
$MA_POS_LIMIT_MINUS[AX3]=-23.25;
$MA_POS_LIMIT_PLUS[AX3]=0.75
else
```

Fadal Siemens Spindle Parameters

Table 1: Baldor Spindle Motors Only

	Version	v1.81	v1.81&v2.01	v1.81	v2.01	v1.81
	Motor type	15hp-810	15hp-840D	20hp-810D	20hp-810D	20hp-810D
	Brand	Baldor	Baldor	Baldor	Baldor	Baldor
	Part no.	release ok	release ok	New style	New style	New style
Description	MD					
Motor nominal power	1130	11.19	11.19	15	15	15
Motor nominal current	1103	33.2	33.2	50	50	50
Motor nominal voltage	1132	225	225	230	230	230
Motor rated speed	1400	1760	1760	1750	1760	1750
Motor noload freq	1134	60	60	60	60	60
Motor noload voltage	1135	220	220	224	224	224
Motor noload current	1136	15.69	15.69	20.118	20.118	24.2711
Stator cold resistance	1137	0.142	0.142	0.109	0.109	0.060
Rotor cold resistance	1138	0.058	0.058	0.055	0.055	0.060
Stator leakage reactance	1139	0.425	0.425	0.289	0.289	0.130
Rotor leakage reactance	1140	0.425	0.425	0.289	0.289	0.130
Magnetizing reactance	1141	8.069	8.069	6.411	6.411	5.198
Field weakening speed	1142	3040	3040	2973	2973	3043
lh curve upper speed	1143	0	0	6000	0	0
Motor max allowed speed	1146	7500	7500	7500	7500	7500
lh curve gain	1144	100	100	100	100	100
Motor inertia	1117	0.048	0.048	0.053	0.053	0.064
Stall torque reduction	1145	100	100	100	100	100
Motor temp warn limit	1602	150	150	120	120	120
Motor code	1102	99	99	99	99	99
Alarm mask power on	1600	112h	112h	112h	112h	112h
Enc resol motor	1005	1000	1000	1000	1000	1000
Num current filters	1200[0]	2	2	2	2	2
Filter types	1201[0]	0	0	0	0	0
Current filter1 freq.	1202[0]	250	2000	300	2000	2000
Current filter1 damping	1203[0]	1	0.7	0.8	0.7	0.7
Current filter2 freq.	1204[0]	250	250	1200	300	300
Current filter2 damping	1205[0]	1	0.7	0.7	0.7	0.7
Power limit	1235[0]	250	250	200	200	200
Power limit	1235[1]	250	100	200	200	200
Power limit	1235[2]	100	100	200	200	200
current limit	1238		230	200	150	150
Motor fixed temp.	1608		30	30	60	60
Speedctrl gain	1407[0,1,2]	8,8,8	8,12.7,12.7	13,13,13	17.689	17.816
Encoder resolution	31020	1000	1000	1000	1000	1000

Table 2: Siemens Spindle Motor Only

	Version	v2.01
	Motor type	50HP-810D
	Brand	Siemens
	Part no.	1ph7167-2*d
Description	MD	
Motor nominal power	1130	28
Motor nominal current	1103	68.3
Motor nominal voltage	1132	312
Motor rated speed	1400	1000
Motor no-load freq	1134	34.2
Motor no-load voltage	1135	294
Motor no-load current	1136	33.1
Stator cold resistance	1137	0.062
Rotor cold resistance	1138	0.045
Stator leakage reactance	1139	0.151
Rotor leakage reactance	1140	0.22
Magnetizing reactance	1141	5.5
Field weakening speed	1142	1180
Ih curve upper speed	1143	1700
Motor max allowed speed	1146	8000
Ih curve gain	1144	136
Motor inertia	1117	0.23
Stall torque reduction	1145	61
Motor temp warn limit	1602	150
Motor code	1102	99
Alarm mask power on	1600	0000h
Enc resol motor	1005	2048
Num current filters	1200[0]	0
Filter types	1201[0]	0
Current filter1 freq.	1202[0]	0
Current filter1 damping	1203[0]	0
Current filter2 freq.	1204[0]	0
Current filter2 damping	1205[0]	1
Power limit	1235[0]	250
Power limit	1235[0]	250
Power limit	1235[2]	100
current limit	1238	200
Motor fixed temp.	1608	0
Speedctrl gain	1407[0,1,2]	47.739
Encoder resolution	31020	1000

C-axis default ratio

Siemens controller with Baldor motors need to be calibrated.
Please review procedure STD_0030.

Along with this calibration, the C-axis default ratio values would be:

\$MA_DRIVE_AX_RATIO_DENOM	31050[0]	100000
\$MA_DRIVE_AX_RATIO_DENOM	31050[1]	100000
\$MA_DRIVE_AX_RATIO_DENOM	31050[2]	100000
\$MA_DRIVE_AX_RATIO_NUMERA	31060[0]	194000
\$MA_DRIVE_AX_RATIO_NUMERA	31060[1]	194000
\$MA_DRIVE_AX_RATIO_NUMERA	31060[2]	51600

Section 08: Siemens 50 Taper

MACHINE OVERVIEW

There are a number of new items on the FADAL Siemens 6535-810D.

The machine's hardware is as follows:

PCU20 pendant, NC 3.3.27 export version, Shop Mill 6.1.3, PLC G2 V2.01 A7, BT50 taper and a Siemens spindle motor.

The listing of new and related major components in the machine's electrical cabinet is as follows: (refer to WRG-0054).

- 55kW I/R module
- 810D CCU1 with 2x 9Amp power sections
- One additional power section for the Z-axis
- One 85Amp Spindle power section
- Added an A-axis module (pre-wired)

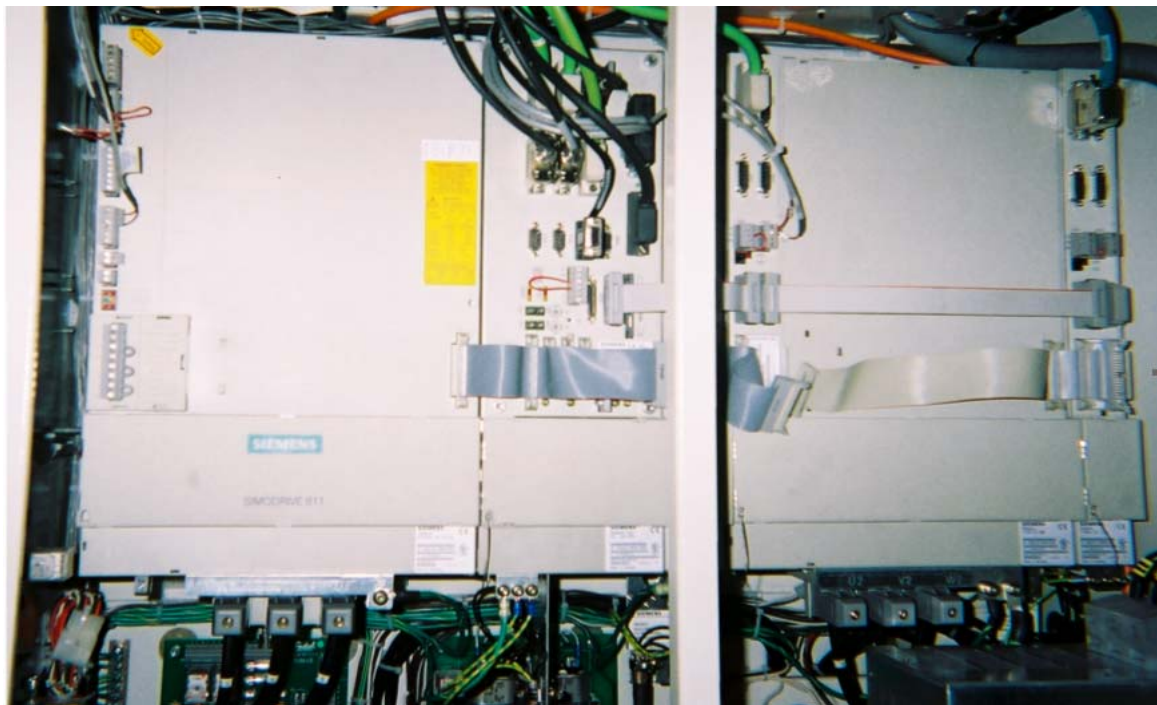

The slots are configured as follows: (refer to WRG-0054).

Slot Number	Description	Drawing Symbol
Slot 1	X-axis Feed Drive	(X)
Slot 2	Y-axis Feed Drive	(Y)
Slot 3	Z-axis Scale Feedback	(Z')
Slot 4	X-axis Scale Feedback	(X')
Slot 5	Y-axis Scale Feedback	(Y')
Slot 6	Z-axis Feed Drive	(Z')
Slot 7	Main Spindle Drive	(C)
Slot 8	A-axis Feed Drive	(A)

Start-up FADAL 6535_810 Jog MPF0

Channel interrupt Stop: No NC Ready

Program aborted ROV

3000 ↓ : Emergency stop

Drive configuration

Slot	Drive	Active	Drive	Module	Power	Sect	Current
1	1	Yes	SRM (FDD)	810D-1	14	H	9/18A
2	2	Yes	SRM (FDD)	810D-2	14	H	9/18A
3	5	No	SRM (FDD)	810D-3		H	
4	4	No	SRM (FDD)	810D-4		H	
5	6	No	SRM (FDD)	810D-5		H	
6	3	Yes	SRM (FDD)	810D-6	16	H	18/36A
7	14	Yes	ARM (MSD)	1 axis	0A	H	85/110/127A
8	7	No	SRM (FDD)	1 axis	14	H	9/18A
9						H	
10						H	

General MD Channel MD Axis MD **Drive config.** Drive MD Display MD File functions

Insert module... Delete module Select power sec. Save Abort OK

The listing of new items is as follows:

1.The first Siemens spindle motor on a Fadal machine. This spindle motor is about 50hp with noted ~510nM of torque from the Dyno tester. It has a direct drive cogged belt so no spindle calibration is necessary (M83 and M84). It has a max 8000rpm and is limited to 7500rpm. There are no gear changes and it is direct drive.

This new spindle motor requires bootfile, HS14.

The following is a listing of the Dive machine data parameters:

Description	Drive MD	Value
motor nominal power	1130	28.000
motor nominal current	1103	68.300
motor nominal voltage	1132	312.000
motor rated speed	1400	1000.000
motor nominal freq.	1134	34.200
motor no-load voltage	1135	294.000
motor no-load current	1136	33.100
stator cold resistance	1137	0.062
rotor cold resistance	1138	0.045
stator leakage reactance	1139	0.151
rotor leakage reactance	1140	0.220
magnetizing reactance	1141	5.500
field weakening speed	1142	1180.000
lh curve upper speed	1143	1700.000
motor max allowed speed	1146	8000.000
lh curve gain	1144	136.000
motor inertia	1117	0.230
stall torque reduction	1145	61.000
motor temp warn limit	1602	150.000
motor code	1102	99.000
alarm mask power on	1600	0000h
enc resol motor	1005	2048.000
numb current filters	1200[0]	0.000
current filter2 freq.	1204[0]	0.000
current filter2 damping	1205[0]	1.000
power limit	1235[0]	250.000
power limit	1235[1]	250.000
power limit	1235[2]	100.000
current limit	1238	200.000
motor fixed temp.	1608	0.000
speedctrl gain	1407	47.739

2.The X, Y and Z-axes limits are 65"x35"x34". The Z-axis limits of the 50 Taper BT are different than the 40 Taper because of the spindle housing is larger. The following is a listing of the Axis machine data parameters:

6535/810-50taper only spec's		X Axis	Y Axis	Z Axis	C Axis
Description	MD				
pos_limit_plus	36100	-32.55	-17.55	-33.25	n/a
pos_limit_minus	36110	32.55	17.55	0.75	n/a
ax_velo_limit	36200	n/a	n/a	n/a	8000
spind_velo_limit	35100	n/a	n/a	n/a	7500
gear_step_max_velo	35110[0]	n/a	n/a	n/a	7500
gear_step_max_velo	35110[1]	n/a	n/a	n/a	7500
max_ax_accel	32300	70	70	70	10
max_ax_velo	32000	900	900	700	8000
posctrl_gain[0]	32200[0]	3.4	3.4	3.4	3.4
posctrl_gain[1]	32200[1]	3.4	3.4	3.4	3.4
posctrl_gain[2]	32200[2]	3.4	3.4	3.4	3.4

3.The BT50 taper turret has 32 pockets. The number of tools in the tool changer is stored in the user data location MD 14510[0] = 32. After entering/ verifying this number, run the TC_BASE program and the number of tools will be created in the tool table.

4. There is a safety cage around the rear control for manually placing tools into the turret. Once this cage is unlocked using a key, the front pendant will be inoperable for moving the turret cw or ccw. A message will be displayed that the rear tool cage is open. The override switch does not have a separate input. It is wired directly into the slide hold control.

There are three new inputs added for this operation, (refer to WRG-0002H):

I65.1 - Turret CW

I65.2 - Turret CCW

I65.3 - Rear Tool Changer Gate

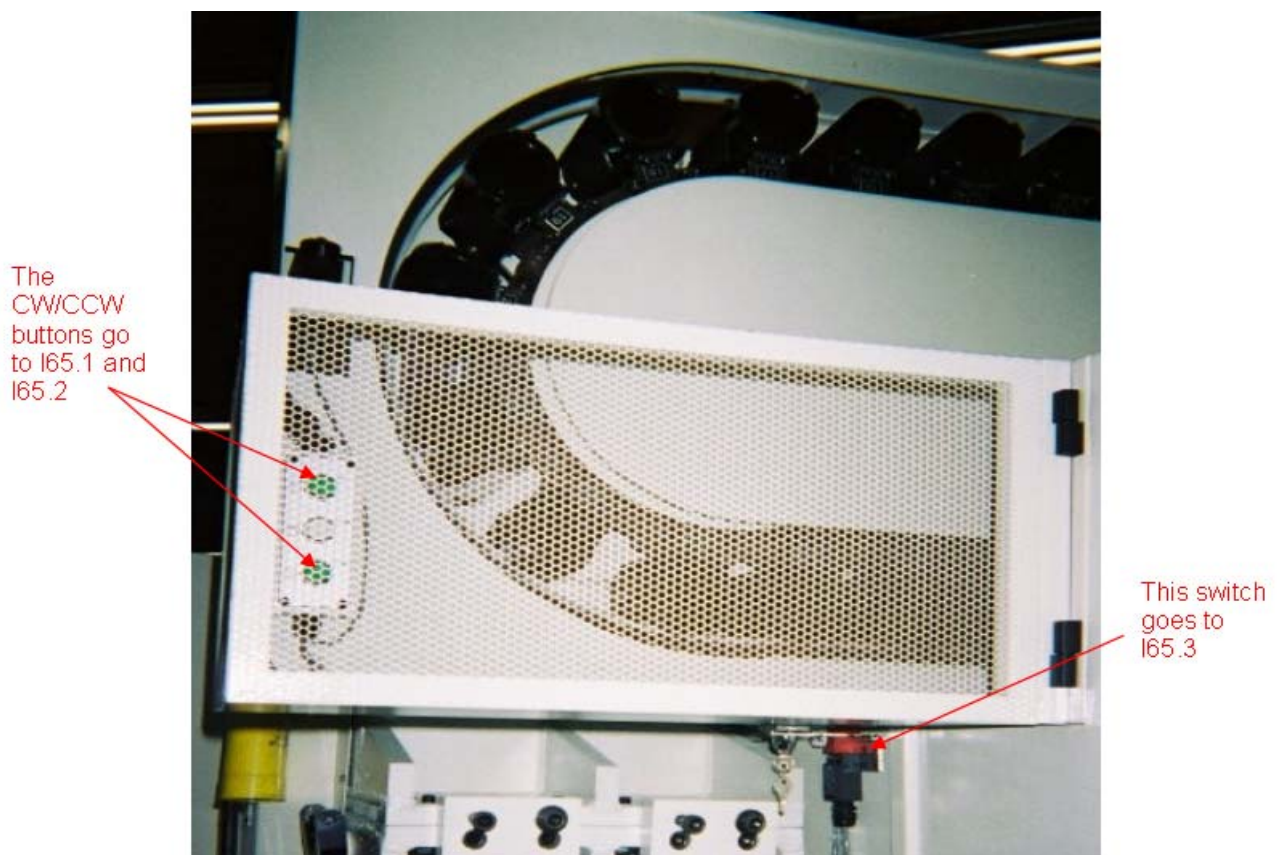

5.A revised PLC program labeled “Fadal G2 version 2.01 A7” takes into account the new I/O and the alarm message. The alarm text, cause and solution are described below.

Alarm 700043 Rear Tool Changer Gate Open

DEFINITION

The rear tool changer gate is unlocked and is open.

REACTION

Display alarm.

Pendant turret cw/ccw is inoperable.

Remote turret cw/ccw control is operable.

Axes movement is disabled.

REMEDY

Close the rear tool changer gate and lock with key.

PROGRAM CONTINUATION

Clear alarm with Reset key. Restart part program.

6. There is a Tool In/Out button on the Spindle head. The pendant must be in the REMOTE Mode for this button to work. (refer to WRG-0002H). There is no input or PLC changes required for this to function since the button is in parallel with the remote tool in/out.

Section 09: Troubleshooting

9.1 Introduction

There are four main locations to gather troubleshooting data when a problem occurs; the alarms and message line located in the upper bar in the normal machine display, the alarm page, the LEDs on the CCU, and the LEDs on the I/R module. If there is no trouble data available at any of these locations, then the trouble may be external to the control, such as a lack of incoming power or a bad power supply.

9.2 The Alarms and Messages Line

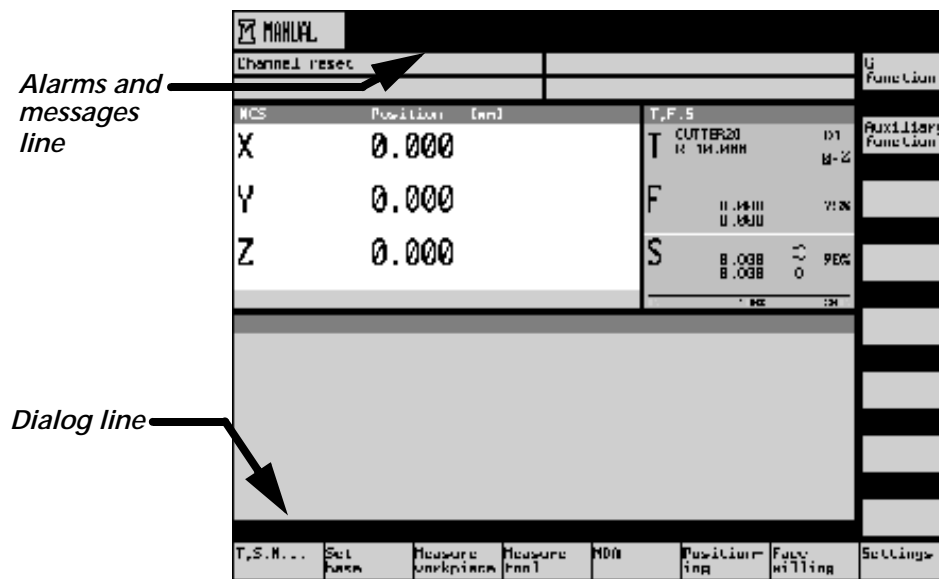

The alarms and messages line displays two lines at a time, which is enough for one alarm/message only. This would be the first place to look for information.

The dialog line also displays extra information in some cases.

9.3 The Alarms/ Messages Page

By pressing the ALARM/SYSTEM hard key, the control switches over to the alarms/messages page. On this page, all the present alarms/messages are displayed at the same time. This is the best place to look for information since the alarms/messages displayed in the alarms and messages line may not be the primary cause of the trouble.

(For a listing of the most common alarms/messages and their respective explanations and remedies, see the Power On Procedure section. In the event you get an alarm that is not listed, or if you need more information, call your service center for help.)

9.4 The Central Control Unit (CCU) Front Panel

There are three indicators located on the CCU front panel. There are two columns of individual LEDs and a seven segment LED display.

LEDs (left column)	Green Red Red Yellow	+5V: Lights when the supply voltage is in the tolerance range. NF: Lights when the NCK or PLC watchdog has operated SF: Lights in case of drive faults. Goes out when the system has run up and is operating properly. CB: Lights when data is being transmitted via the MPI interface.
LEDs (right column)	Green Red Red Yellow Yellow	PR: PLC-RUN state PS: PLC-STOP state PF: Lights in an event of PLC fault. PFO: PLC-FORCE state - : Not used (lights briefly on reset)
H3	7-segment	Software-supported output of test and diagnostic signals.

The left column of LEDs is for the NCK functions. The right column of LEDs is for the PLC. The seven-segment display is for general purposes.

The normal state for these LEDs is as follows:

- The +5VDC and PR LEDs (green) are on.
- The CB LED (left column, yellow) flashes to signal ongoing communications.
- The seven-segment display (H3) shows a “b”.

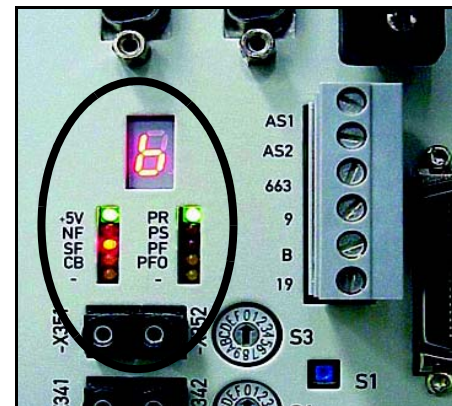

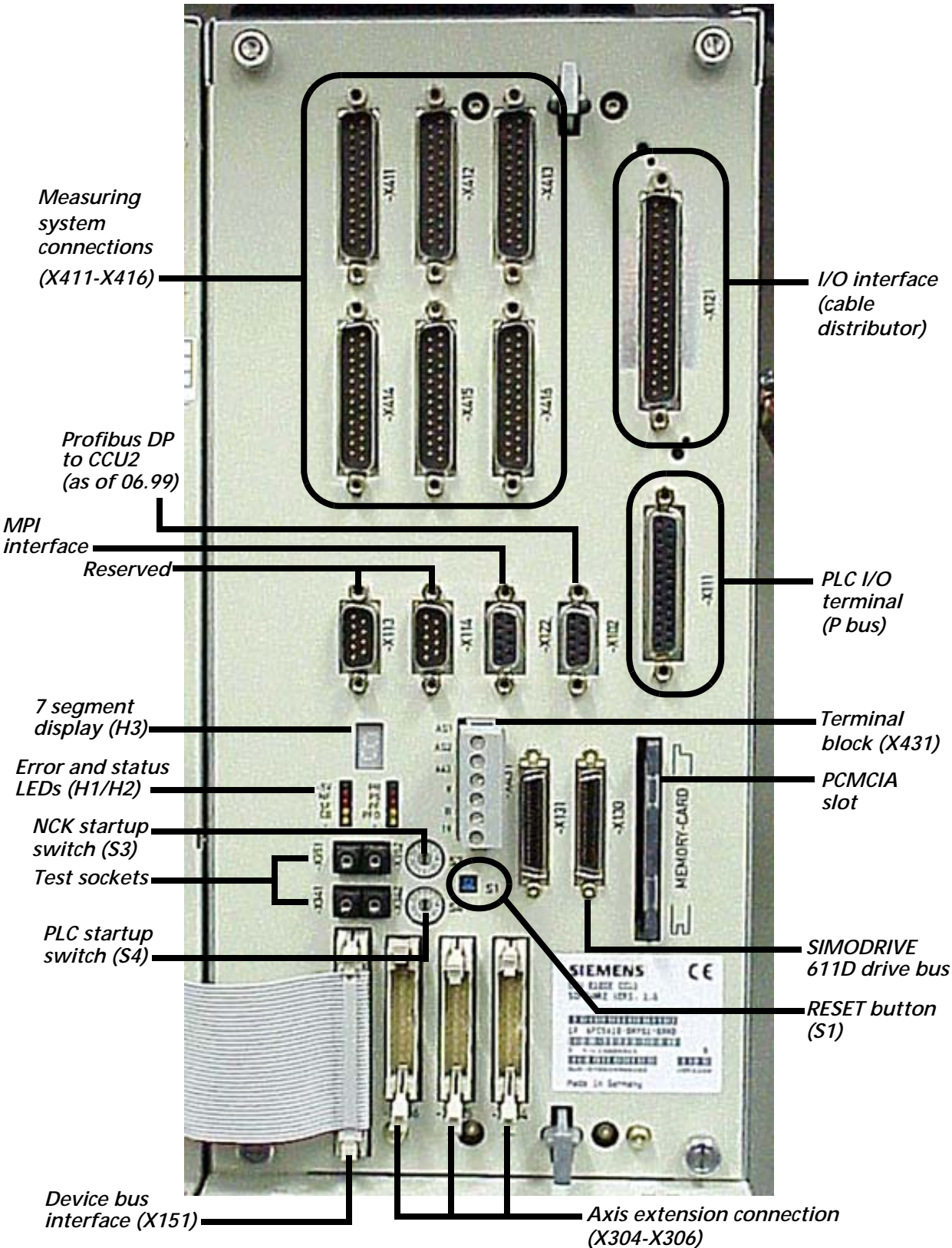

• CCU front panel.

**9.5 The In-feed/
Regeneration (I/R)
Module**

The I/R module is the power supply for the 810D. There are several voltages generated for the logic electronics and there are 600 VDC output for the drives to run the motors. There are six LEDs and several test points to check for those voltages.

CAUTION

600 VDC carries a lot of power. Even brief contact can result in fatal bodily harm. Only an experienced professional should access the cabinet to perform high voltage checks.

Normally, there should be +24VDC, -24VDC, +15VDC, and -15VDC. Only the yellow LED is on during normal operation. The DC link voltage is 600 VDC (+300 VDC and -300 VDC) for a regulated module (I/R) and about 550 VDC for an unregulated one (UE). Check with an authorized service representative to verify which type of module is installed.

9.5.1 The I/R Module

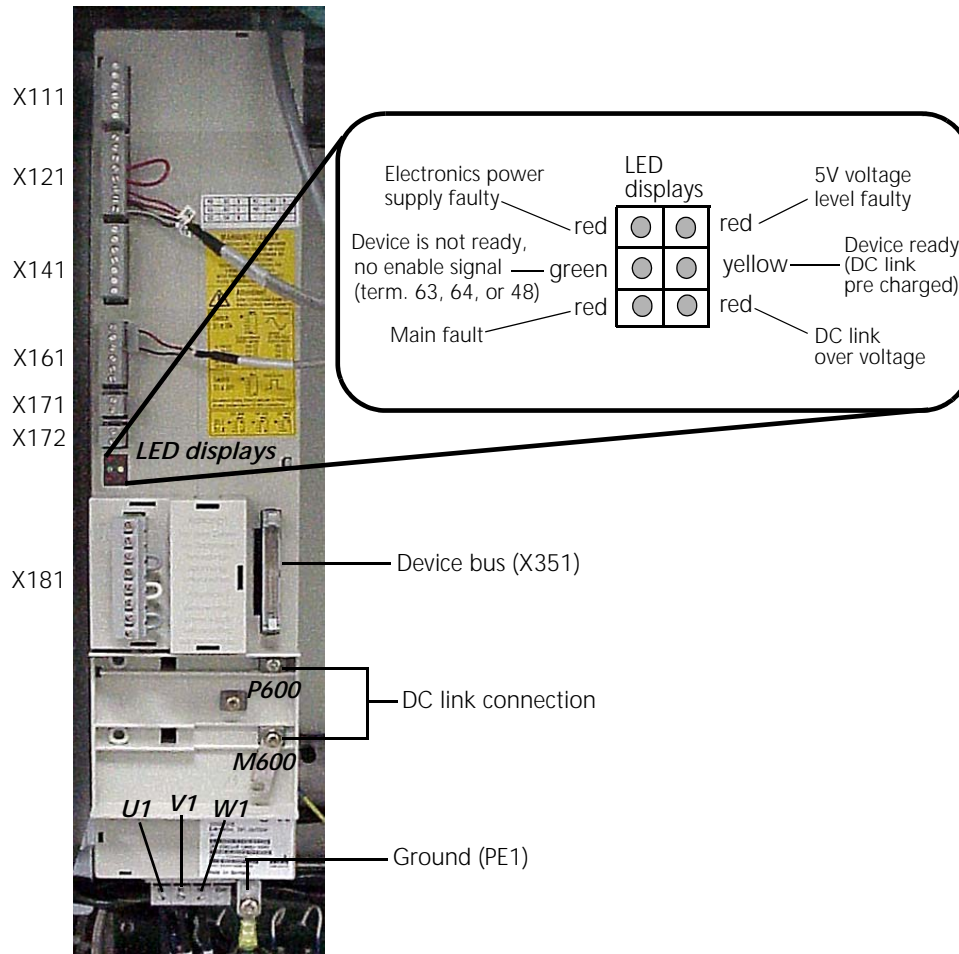

7	X141	P24	O	+20.4...28.8 V/50 mA	1.5 mm ²	I/R, UE, monitoring module
45	X141	P15	O	+15 V/10 mA	1.5 mm ²	
44	X141	N15	O	-15 V/10 mA	1.5 mm ²	
10	X141	N24	O	-20.4...28.8 V/50 mA	1.5 mm ²	
15 ²⁾	X141	M	O	0V	1.5 mm ²	
R ⁶⁾	X141	RESET	I	Term. 15/R _E = 10k ohm	1.5 mm ²	
P600		DC link	I	+300 V		
M600		DC link	I	-300 V		

The description of the alarms is normally enough to pin-point the cause of a problem, but in some cases extra help is needed. Write down all alarm numbers and any other information that could be helpful, as well as, any factor that may have contributed to the problem. This information will allow a Fadal representative to further troubleshoot the problem.

How to monitor the DATC interface.

The dual Arm Tool Changer in the Siemens equipped machine works out of a 9-bit signal path

PLC inputs/outputs

INPUTS	
I38.1	DATC tool magazine count impulse
I38.2	DATC busy - active low
I38.3	DATC error - active low
I38.4	DATC draw-bar - active low
OUTPUTS	
Q41.0	DATC strobe
Q41.1	DATC d0
Q41.2	DATC d1
Q41.3	DATC d2
Q41.4	DATC d3 draw-bar

These signals can be monitored in the Diagnostic area, PLC page. The next table shows the different bit combinations that send a command to the 1330 board.

Signals as they appear in the PLC diagnostic screen.

Q42.5 (d3)	Q41.3 (d2)	Q41.2 (d1)	Q41.1 (d0)	Command
	1	1	1	Turret CW
	1	1	0	Turret CCW
	1	0	1	Tool Change
	1	0	0	Bucket Up/Down
	0	1	1	Arm Forward
	0	1	0	Arm Reversal
	0	0	1	Error retrieval
	0	0	0	Idle
1	0	0	0	Draw-bar

A low to high transition at Q41.0 (the strobe signal) starts the process. The DATC busy signal (I38.2) remains active until the command is executed entirely. The DATC error signal (I38.3) is active in the event of any error conditions in the 1330 board.

**HOW TO RE-SET THE
TOOL MAGAZINE
LOCATION.**

It is possible to lose the proper pocket number in the tool magazine turret due to an emergency stop while the turret is rotating to get to a new position. If the turret stops in between pockets the window for generating the counting pulse may be missed so the turret may be off by one pocket count.

Once the E-Stop condition has been removed, the first thing to do is to return the magazine to a good pocket position by pressing the Turret CCW or Turret CW hard key.

Once one of the pockets is aligned in the proper tool change position, the tool magazine counter must be verified.

To verify the turret counter:

- Press E-Stop.

- If in Shop Mill, go to the ISO screens:

- Press the Shift and System keys (press menu-select key in the MMC103).

- Press the CNC ISO Soft Key.

- Press the CNC ISO check-mark SK.

- Once in ISO, continue from here

- Press the Shift and System keys (press menu-select key in the MMC103).

- Press the Diagnosis SK.

- Press the PLC (also called PLC Status) SK.

- In the first row of the first column (Operand), type "C5".

- Press the INPUT Hard Key. The cursor jumps to the second column (Format).

- Type "D"

- Press the INPUT Hard Key. The cursor jumps to the second row in the first column (Operand).

- Type "DB92.DBW0".

- Press the INPUT Hard Key. The cursor jumps to the second column (Format).

- Type "D"
- Press the INPUT Hard Key.
- BOTH numbers should be the same among them. They also must be the same as the number of the pocket aligned in the tool change position.
- If all three numbers coincide, the turret counter is O.K.
- If the numbers are different, press the Change vertical SK in the right.
- Type the number of the pocket in the tool change position in the third column (Value). Enter the same number for BOTH rows.
- Press the Accept vertical SK. Both C5 and DB92.DBW0 must show the same number. This number must be the same as the one for the turret pocket in the tool change position.
- Get out of E-Stop and test the tool magazine with the following MDA program:

```
T#  
G4F2  
M02
```

Where # is the name of the tool contained in the turret pocket you want to call to the tool change position. The turret must rotate to bring the pocket in question to the tool change position and stop.